

Motor Protection

A. Motor Cooling Methods

Side Channel Top Discharge

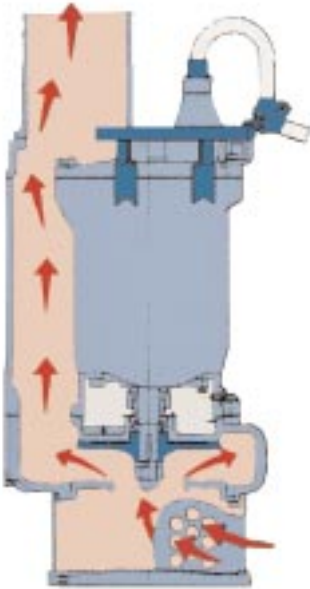

Cast as an integral part of the motor casing, the side discharge channel allows water to cool the motor as it flows past the inner motor casing. This design feature permits the unit to operate at low water levels for extended periods of time and allows the overall diameter of the pump to be reduced for installation in confined spaces. Even in run-dry conditions, air will be forced through the channel thereby cooling the motor.

Models

LSC, KTV, KTVE, KTZ, KRS (except KRS1022)

Top Discharge - Flow Through Design

The top flow design incorporates an inner and outer motor casing. Water is allowed to flow completely around the motor on its way to the top centerline discharge. This design permits the unit to operate at low water levels for extended periods of time and allows the overall diameter of the pump to be reduced for installation in the smallest confined spaces. Even in run-dry conditions air will be forced through the channel thereby cooling the motor.

Models

LB, KRS1022, LH

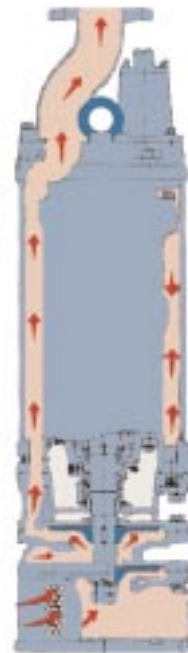

Motor Protection

B. Insulation Classes

The chart below shows the temperature ratings for insulation classes used for electric motors. Tsurumi typically utilizes 4 of the below classes in their submersible pumps, classes B to H. The amount of temperature rise above ambient temperature is dictated by the motor compartment size (cooling area). That is to say the higher the temperature rating of the insulation system the smaller the motor compartment requirement. The difference between Tsurumi and other manufacturers is Tsurumi always utilizes the largest motor enclosure. For example should a B- or KTZ-series be ordered with class F insulation it is supplied with a class E motor compartment. This affords a higher degree of cooling and extends the life of the motor.

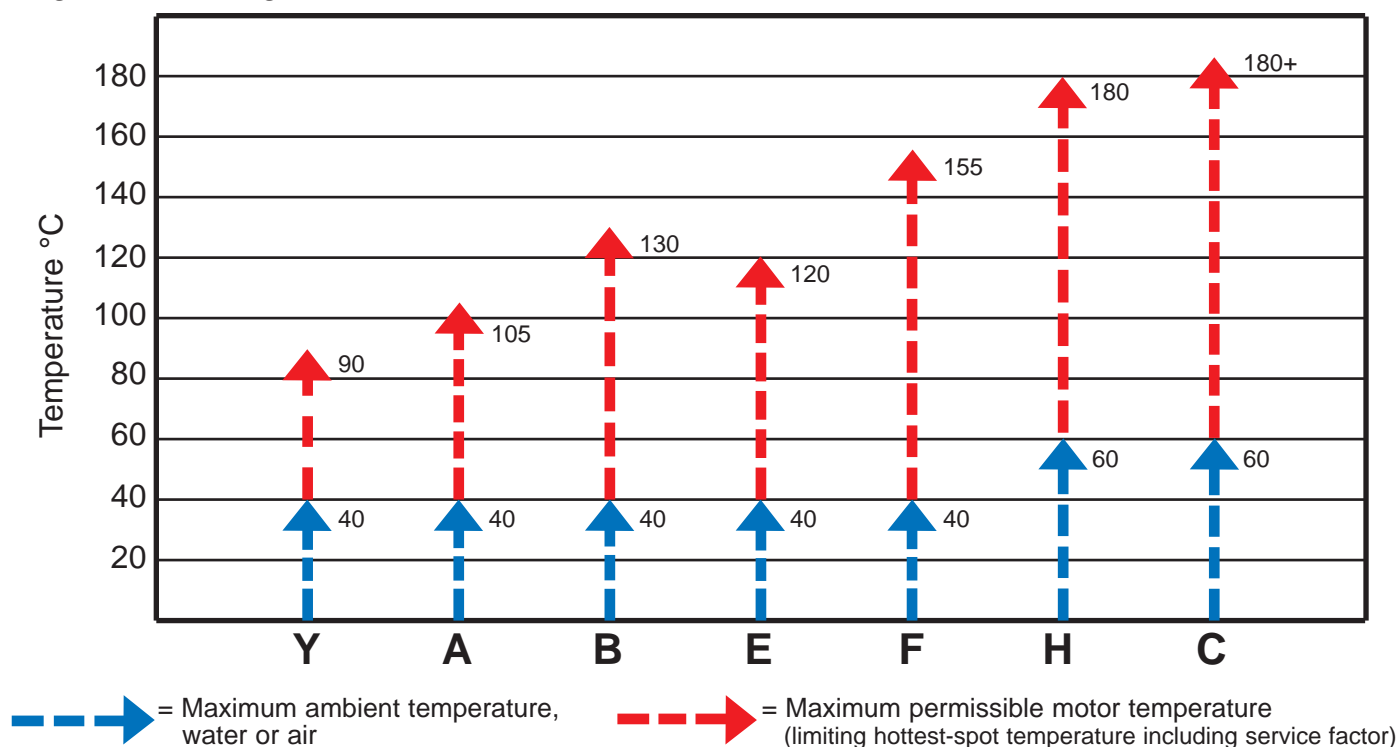

AMBIENT TEMPERATURE RATINGS:

Tsurumi lists the maximum ambient temperature rating of class B, E and F insulation at 40°C. Based on maximum permissible rating, if you rate the ambient temperature higher, you must raise the actuating temperature of the internal motor protection (if supplied). If the actuating temperature of the motor protection is increased motor insulation and bearing life will be decreased.

The motor protection used in Tsurumi submersible pumps is calibrated to actuate at or below the rated temperature of the insulation.

When rolling bearings are operated in an environment exceeding 120°C the basic load rating (used to calculate bearing life) must be reduced by 5% for each 25°C above 120°C. Bearings used in Tsurumi pumps are selected to take this fact into consideration.

Due to the larger motor compartment Tsurumi submersible pumps are slower to overheat due to temporary voltage fluctuations or sudden increases in the specific gravity of the fluid, thereby reducing nuisance tripping of the motor protectors.

Since Tsurumi class E insulation operates within the same parameters as a class F competitors' motor and operates at a lower temperature, Tsurumi class E motors are equal or superior to competitors' class F motors.

Motor Protection

C. CTP Motor Protector 0,4kW - 7,5kW

The Circle Thermal Protector (CTP) is supplied as standard on all units from 0,4kW to 7,5 kW

The Tsurumi CTP is a unique motor protector in that it not only senses excess heat build up in the motor, but will also sense excess amperage draw. The CTP protects the motor from the following problems that may occur during operation:

1. Locked rotor due to blockage or mechanical failure
2. Phase imbalance
3. Extended run dry conditions
4. Single phasing in three phase units
5. Low voltage

In order to provide maximum protection the Tsurumi CTP is mounted directly over the windings of the motor.

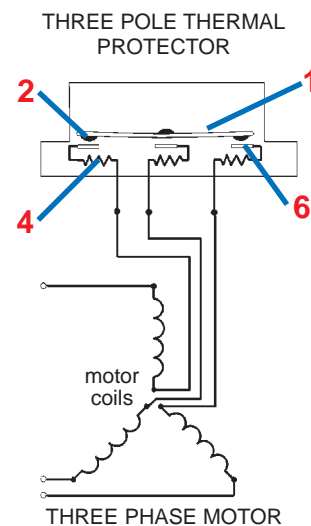
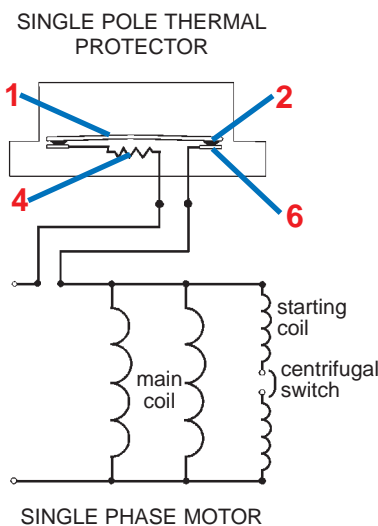
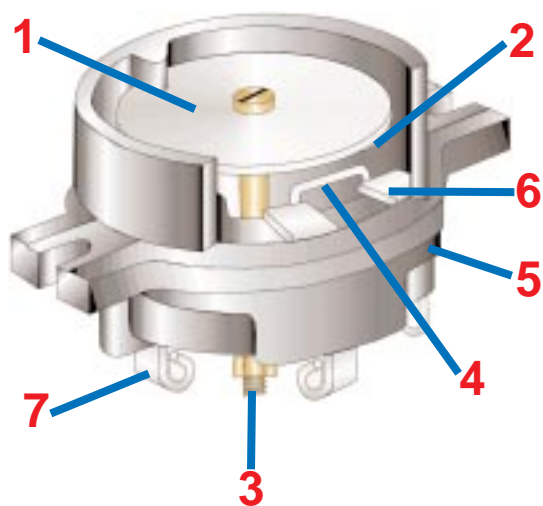

SNAP ACTING DISK

The snap acting disk (1) is a bi-metallic disk that will deform in a predictable manner when a certain temperature is reached. Attached to the bottom of the disk are the movable contacts (2).

CALIBRATION BOLT&NUT

The calibration bolt & nut (3) allow the unit to be calibrated to actuate at a predetermined temperature with a $\pm 5^{\circ}\text{C}$ accuracy.

HEATER (S)

The heater element (4) is the amperage sensing part of the CTP. Should the motor windings start to draw excess amperage, the heater element will heat the snap acting disk up until the disk reaches actuating temperature.

HOUSING

The CTP housing (5) is made of temperature resistant bakelite and provides a sturdy, insulated mounting base for the stationary contacts (6) and terminals (7).

The CTP is supplied in two different configurations. One is a single pole model which is used for single phase units. The other is a three pole model which is used in three phase units. Should the actuating temperature be reached the snap acting disk will open the circuit as shown in the three phase motor diagramme. When the motor cools down to a safe operating temperature the CTP will automatically reset and the motor will restart. In addition the CTP is sized according to horsepower and voltage.

Motor Protection

CIRCLE THERMAL PROTECTOR (CTP) MODEL CODING

KA **311** **DA** **X** **L** **78** **H**
(1) **(2)** **(3)** **(4)** **(5)** **(6)** **(7)**

(1) Type	(2) Ref. No.	Phase	kW	Poles	(3) Bimetal Code
KA	112	1	<1,5	1	AB, BA, BB, BP, LB, etc.
KA	142	1	<1,5	1	
KA	113	1	<2,2	1	CB, CC, MF, ME, etc.
KA	143	1	<2,2	1	
KA	311	3	<2,2	3	DA, DB, DP, etc.
KA	313	3	<2,2	3	GB, GC, GD, GQ
KA	314	3	<7,5	3	HK, HL, HR, HM
KA	315	3	<15	3	JL, JN, JT, JX, etc.
KA	316	3	<22	3	NC, NE, NS

(4) Actuating temp. code	Actuating temp.
A	135°C
B	140°C
C	145°C
D	150°C
E	155°C
F	160°C
G	165°C
H	170°C
I	175°C
J	50°C
K	55°C
L	60°C
M	65°C
N	70°C
O	75°C
P	80°C
Q	85°C
R	90°C
S	95°C
T	100°C
U	105°C
V	110°C
W	115°C
X	120°C
Y	125°C
Z	130°C

(5) Resetting temp. code	Resetting temp.
A	135°C
B	140°C
C	145°C
D	150°C
E	155°C
F	160°C
G	165°C
H	170°C
I	175°C
J	50°C
K	55°C
L	60°C
M	65°C
N	70°C
O	75°C
P	80°C
Q	85°C
R	90°C
S	95°C
T	100°C
U	105°C
V	110°C
W	115°C
X	120°C
Y	125°C
Z	130°C

(6) Heater No.	(7) Remarks
00: No Heater	H: High capacity contacts etc.
01-499	

Motor Protection

D. MTP Motor Protector 11kW and above

The Minature Protector (MTP) is supplied as standard on all units 11kW and above.

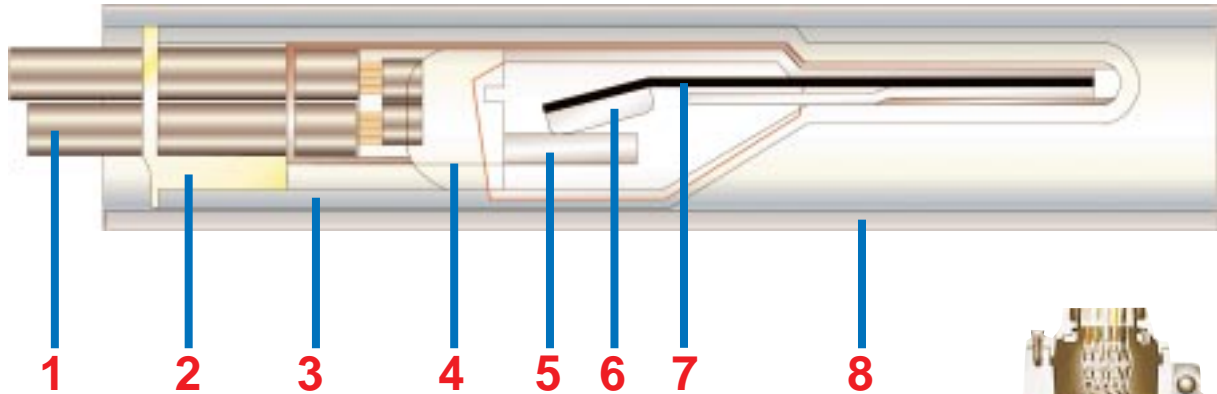

MTP

MATERIALS OF CONSTRUCTION

- 1 Neoprene Leads
- 2 Epoxy Sealing Compound
- 3 Plated Steel Casing
- 4 Ceramic Insulator
- 5 Stationary Silver Contact
- 6 Movable Silver Contact
- 7 Bi-Metal Strip
- 8 Mylar Sleeve

Motor Insulation Class	MTP Model No.	Actuating temp.	Resetting temp.
E	9700K-01-215	120 ± 10°C	85 ± 10°C
B	9700K-46-215	135 ± 10°C	85 ± 10°C
F	9700K-06-215	150 ± 10°C	85 ± 10°C

PRINCIPLE OF OPERATION

The MTP is placed in the motor winding. Should the winding temperature rise to the actuating temperature the bi-metal strip (7) will snap the movable contact (6) open.

Tsurumi incorporates three MTPs in all three phase units (one in each winding).

The MTPs are connected in series. If only one winding reaches the actuating temperature the power is cut off to all windings.

The MTP circuit can be wired in series with the motor control circuit in which case the motor will restart automatically when the unit drops below the reset temperature or they can be wired to an independent relay that requires a manual reset.

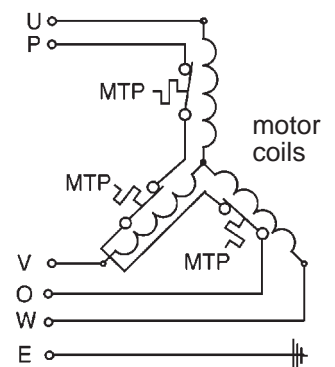

THREE PHASE MOTOR