

SERIES
CZ

SUBMERSIBLE
SMASHING CUTTER PUMPS

HEART SHAPED SUCTION

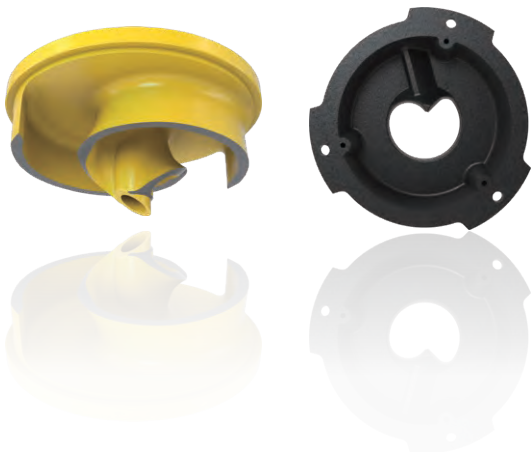

SUBMERSIBLE SMASHING CUTTER PUMPS

HEART SHAPED SUCTION

CZ-series



CZ-series Movie



Tsurumi CZ-series pumps are heavy-duty submersible smashing cutter pumps made of cast iron, for sewage and wastewater, equipped with a newly developed crushing mechanism.

With innovative and unique impeller design equipped with two Rotating Leading Blades and original Heart-shaped Stationary Suction Blade, CZ-series provides optimal crushing and shredding of the solid wastes. It can cut solid matters as well as handle long fibrous wastes.

The game-changing Extended Rotating Guide provided on the impeller remarkably eradicates the retention of solid wastes at the center of the impeller.

Additionally, the high-performance two vaned semi-open channel impeller, in combination with other hydraulic components provides excellent pump efficiency to the CZ-series.

Furthermore, in order to maintain the crushing and shredding performance for a long time, the impeller and suction cover are made of ductile cast iron, which is particularly strong against impact forces. Similarly, the pump casing material has been upgraded from Tsurumi's other conventional wastewater pumps from FC200 to FC250 gray cast iron. (Equivalent to EN-GJL-200 to EN-GJL-250)

These factors make the CZ-series pump a high-grade, innovative product that prevents clogging of the pump and provides better solid handling capabilities.

Tsurumi pumps come packed with a number of original technologies we have developed and honed over years of research, including an anti-wicking cable, motor protector, dual inside mechanical seals with silicon carbide faces and Oil Lifter. Highly reliable and durable, Tsurumi pumps are designed and built for sound quality and prolonged continuous operation. All models are compatible with the guide rail fitting device, allowing for easy installation and maintenance.



THE NEW CRUSHING MECHANISM
CRUSHES and SHREDS
SOLID MATTERS INTO EVEN FINER PIECES!

Comparison of SMASHING CUTTER and TSURUMI CUTTER PUMP			
	Original	Smashing Cutter	Cutter
Aluminium Can			
Plastic Bottle			
Hand Towel			
Wet Wipes			
Face Mask			
Plastic Bag			
Rubber Gloves			
Pantyhose			
Adult Diaper			
Cable			
Rope			
Cardboard			
Polypropylene Band			



CZ-series Web

Model
100CZ43.7

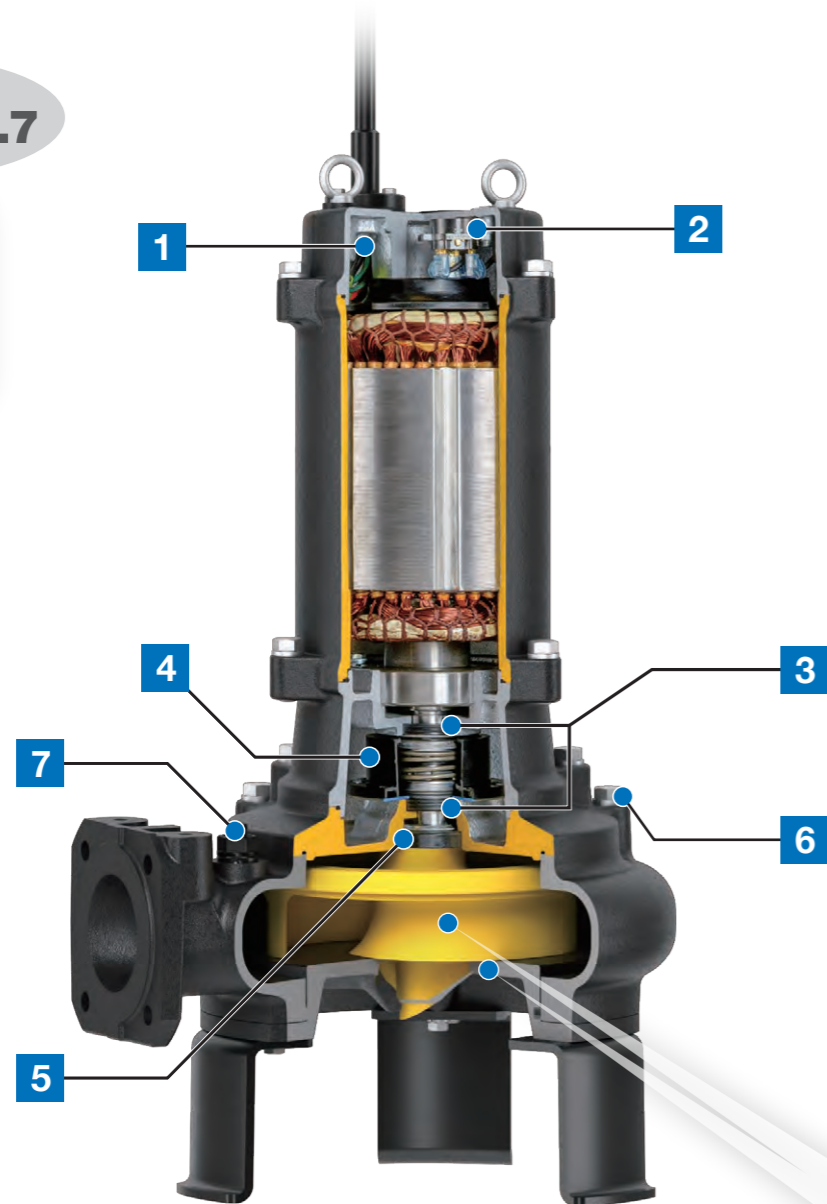

- 1 **Anti-wicking Cable Entry**
Prevents water incursion due to capillary action should the cable sheath be damaged or the end of cable submerged. Also prevents moist air from infiltrating the motor housing and condensation from forming inside the housing due to temperature differences between the housing and outside air.
- 2 **Motor Protector**
Circle Thermal Protector (7.5kW and below)
Directly cuts the motor circuit if excessive heat builds up or overcurrent occurs in the motor.
Miniature Thermal Protectors (11kW and above)
React to excessive heat caused by dry-running. The bimetal strip opens to cause the control panel to shut the power supply.
- 3 **Dual Inside Mechanical Seals with Silicon Carbide Faces**
Isolated in the oil chamber where a clean, non-corrosive and abrasion-free lubricating environment is maintained. Compared with the water-cooled outside mechanical seal, it reduces the risk of failure caused by dry-heating and adhering matter. The silicon carbide provides 5 times higher corrosion, wear and heat resistance than the tungsten carbide. Rubber parts of the upper and lower fixing rings are made of NBR or FPM (FKM), which provides higher resistance to heat and chemicals.
- 4 **Oil Lifter**
Provides lubrication and cooling of the seal faces down to 1/3 of normal oil level, thus maintaining a stable shaft sealing effect and prolonging seal life longer. The Oil Lifter is Tsurumi original design.
- 5 **Oil Seal**
Used as a "Dust Seal", it protects the mechanical seal from abrasive particles.
- 6 **Back Pull-out Design**
Enables the motor to be separated from the pump unit with the impeller attached, by removing the bolts between the oil casing and the pump casing. This design facilitates maintenance and inspection of the principal parts of the pump.
- 7 **Air Release Valve**
Fitted on the pump casing to prevent the air lock. When air flows through the valve, the ball stays at the bottom, but when the pumped water starts to flow, the ball closes the outlet because of its buoyancy.

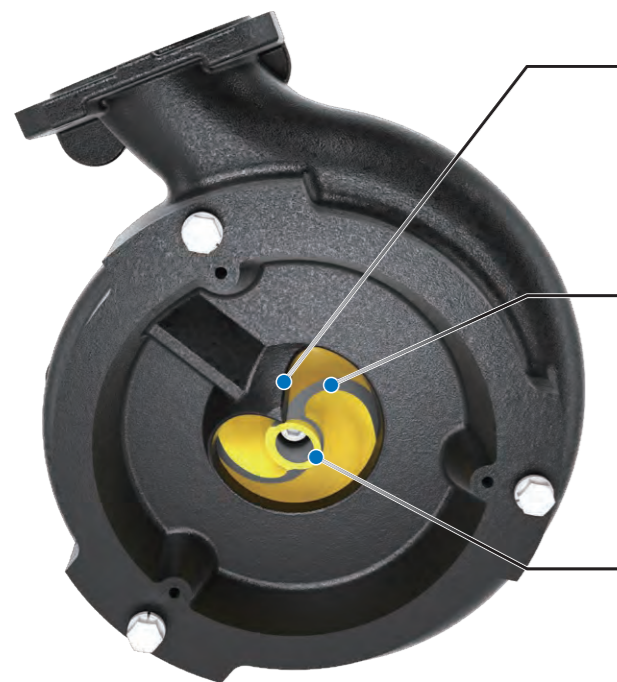

Heart-shaped Stationary Suction Blade

Extremely sharp blade is provided on the suction cover that crushes and shreds any solid with the help of rotating leading blade for better solid handling.

Rotating Leading Blade

The high-efficiency open-type two-vane impeller is equipped with a sharp-edged leading blade, which brings solid matter towards the stationary suction blade at an optimum angle. These two blades work together, acting like scissors, to efficiently cut and shred any solids into pieces allowing them to pass through smoothly.

Extended Rotating Guide

The extended rotating guide prevents the solids from accumulating at the low-pressure suction region at the center of the impeller, which is highly-prone to clogging. The extended rotating guide is designed to guide the wastes into the channel towards the sharp-edged blades and away from the center of the impeller, vastly improving the reliability against clogging.

Impeller & Heart-shaped Suction Cover

– Crushing and shredding performance beyond that of conventional cutter pumps –

Tsurumi's original Heart-shaped Suction Cover is a unique design that improves the conventional Tsurumi cutter pumps by powerfully crushing and finely cutting solid and fibrous matters. Coupled with the new high efficiency two blade hydraulic impellers, CZ-series has greatly enhanced the pump performance while improving the cutting functions. Furthermore, the extended rotating guide on the impeller prevents any waste material clogging in the central part of the impeller and facilitates smooth transfer of waste. Tsurumi is proud to launch the reliable and innovative upgraded cutter pumps, CZ-series.



Semi-open Channel Impeller with Extended Rotating Guide



Heart-shaped Suction Cover

CZ – Smashing Cutter / Heart Shaped Suction –

The CZ-series is a submersible smashing cutter pump specially designed for pumping sewage and wastewater containing various solid waste including fibrous materials. A unique design of heart-shaped suction cover equipped with a sharp-edged stationary blade along with an improved semi-open channel impeller having two sharp-edged vanes incorporates the scissor mechanism. This innovative scissor-like mechanism remarkably enhances the solid handling capabilities. It prevents pump clogging through crushing and shredding of solid objects.

In addition to that, the extended rotating guide equipped on impeller prevents the retention of solid waste at the central part of the impeller, thereby providing a smooth pumping operation.



100CZ43.7



TOS100CZ43.7

Performance Curves

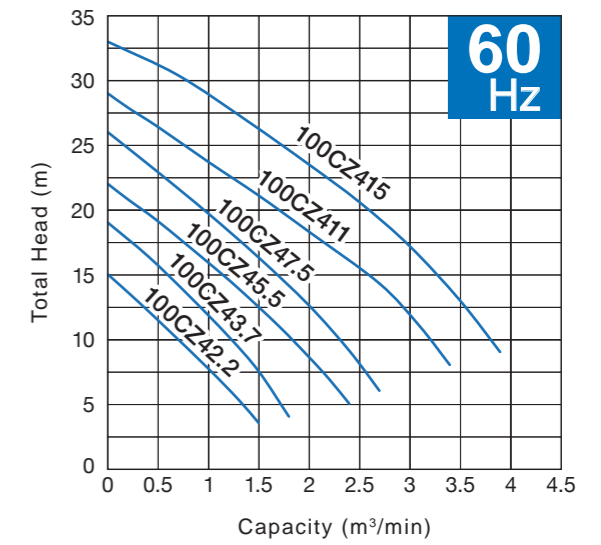
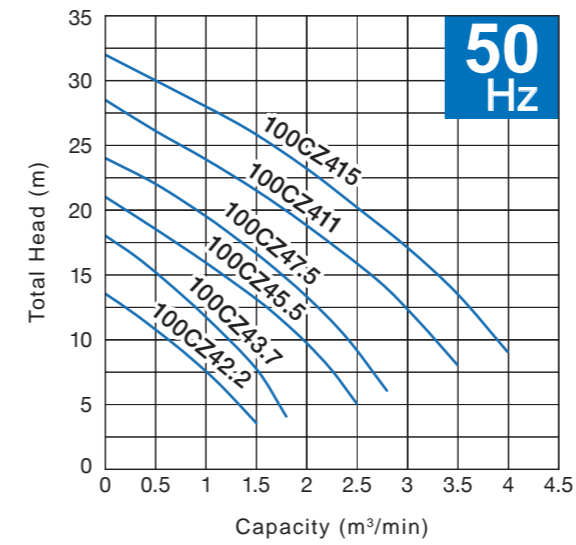

Dimensions

Free Standing

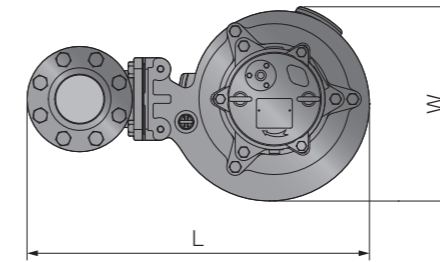

Guide Rail Fitting

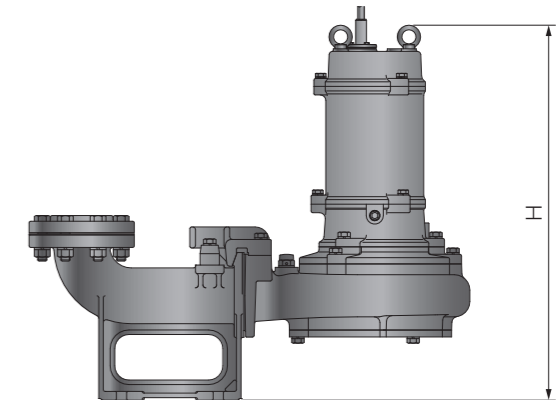
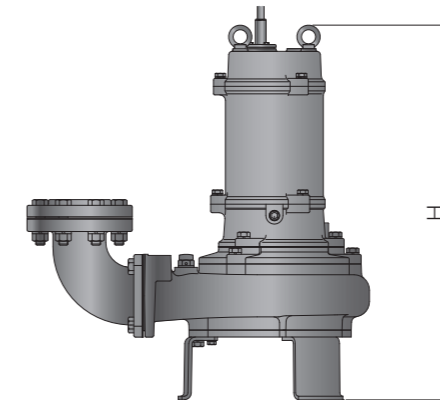
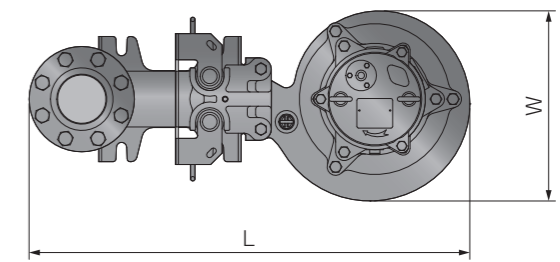

Discharge Bore mm	Model		Motor Output kW	Phase	Starting Method	Solids Passage mm	Dimensions L x W x H mm		Dry Weight* ³ kg		Cable Length m
	Free Standing	Guide Rail Fitting					Free Standing	Guide Rail Fitting	Free Standing	Guide Rail Fitting	
100	100CZ42.2	TOS100CZ42.2	2.2	Three	D.O.L.	30* ²	629 x 341 x 658	787 x 334 x 659	81	69	6
	100CZ43.7	TOS100CZ43.7	3.7		D.O.L.	30* ²	629 x 341 x 708	787 x 334 x 709	92	80	6
	100CZ45.5	TOS100CZ45.5	5.5		D.O.L.* ¹	35* ²	685 x 410 x 930	904 x 391 x 927	166	150	8
	100CZ47.5	TOS100CZ47.5	7.5		D.O.L.* ¹	35* ²	685 x 410 x 911	904 x 391 x 908	174	158	8
	100CZ411	TOS100CZ411	11		Star-Delta	41* ²	722 x 438 x 1000	941 x 438 x 990	231	214	8
	100CZ415	TOS100CZ415	15		Star-Delta	41* ²	722 x 438 x 1070	941 x 438 x 1060	247	231	8

*¹ Star-Delta available upon request

*² Solids larger than aforementioned size can be transferred easily with the help of improved crushing and shredding performance.

*³ All weights excluding cable

Weights of guide rail fitting excluding duckfoot bend



Specifications

		CZ						
		100CZ42.2	100CZ43.7	100CZ45.5	100CZ47.5	100CZ411	100CZ415	
PUMP	Discharge Bore	mm 100						
	Discharge Connection	Threaded JIS 10kg/cm ² Flange						
	Solids Passage	mm	30	35	41			
			Solids larger than aforementioned size can be transferred easily with the help of improved crushing and shredding performance.					
	Impeller	Semi-open Channel Impeller with Two Sharp-edged Vanes and Extended Rotating Guide						
		Ductile Cast Iron JIS FCD500 (EN-GJS 500 equivalent)						
	Heart-shaped Suction Cover	Ductile Cast Iron JIS FCD500 (EN-GJS 500 equivalent)						
	Oil Seal	Nitrile Butadiene Rubber						
	Pump Casing	Gray Cast Iron JIS FC250 (EN-GJL 250 equivalent)						
	Oil Casing	Gray Cast Iron JIS FC250 (EN-GJL 250 equivalent)						
Shaft Seal	Dual Inside Mechanical Seals (with Oil Lifter)							
	Silicon Carbide							
MOTOR	Type	Continuous-duty Rated, Dry-type Induction Motor						
	Output	kW	2.2	3.7	5.5	7.5	11	15
	Phase	Three						
	Pole	4						
	Speed (S.S.) 50/60Hz	min ⁻¹	1500/1800					
	Insulation	F						
	Starting Method	D.O.L.		D.O.L.* ²		Star-Delta		
	Motor Protector (built-in)	CTP			MTP			
	Lubricant	ml	1250	4200	5400	5700		
			Turbine Oil (ISO VG32)					
	Frame	Gray Cast Iron JIS FC200 (EN-GJL 200 equivalent)						
	Shaft	420 Stainless Steel						
	Power Cable	m	6	8				
PVC			Chloroprene Rubber					
Dry Weight* ¹	Free Standing	kg	81	92	166	174	231	247
	Guide Rail Fitting	kg	69	80	150	158	214	231

*1 All weights excluding cable
Weights of guide rail fitting excluding duckfoot bend
*2 Star-Delta available upon request

Model Number Designation

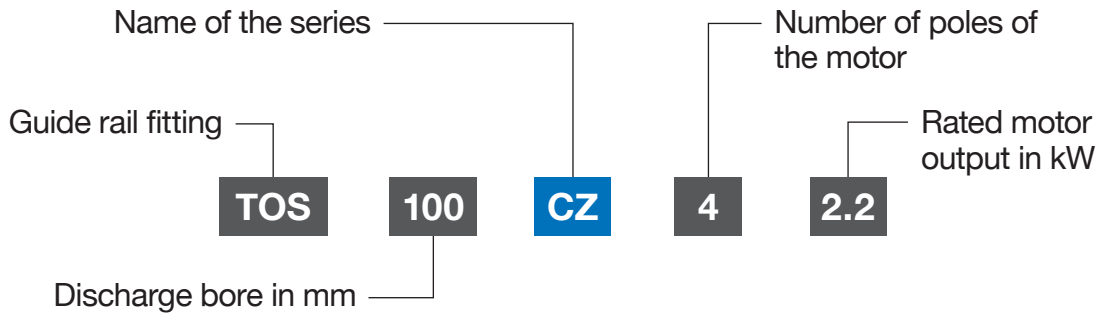

Guide Rail Fitting System

The guide rail fitting system connects the pump to and from the piping easily just by lowering and hoisting the pump, allowing easy maintenance and inspection without the need to enter the sump. The TOS is the guide rail fitting system made of cast iron and is compatible with cast iron pumps.

Accessories

- Duckfoot Bend
- Guide Support
- Guide Hook
- Lifting Chain 5m
- JIS 10kg/cm² Flange

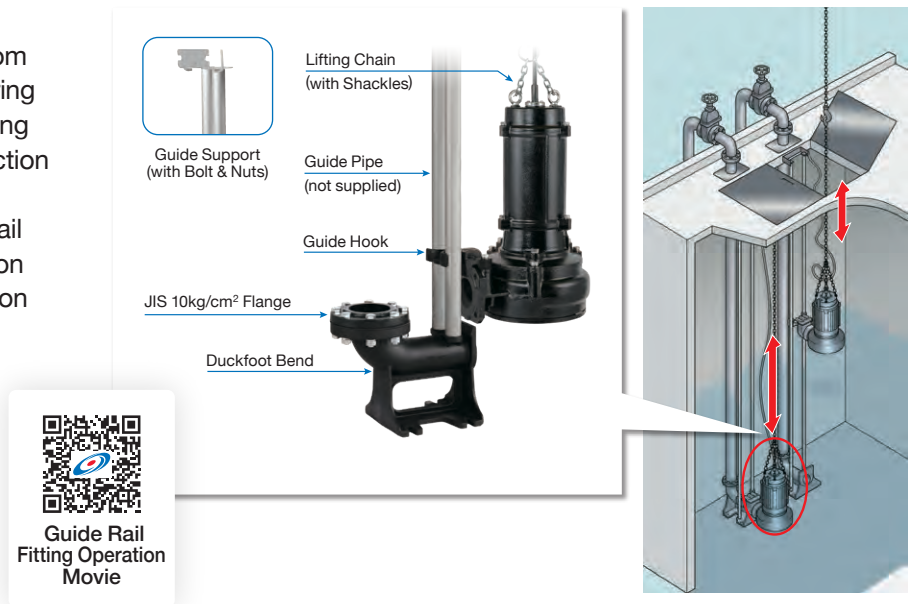

Float Switches

Tsurumi offers two types of float switches (liquid level sensors). A micro-switch is incorporated in both types.

Model MC-2 is a heavy-duty type float switch with a shock absorber. Having equipped with a high grade micro switch, the MC-2 assures trouble-free operation in the liquid containing much suspended solids and floating scum. Either of the two contacts, normally-open or normally-close, can be selected as required.

Model RF-5 is an economy type float which can detect upper/lower limit water levels with single float. The snap on-off action ensures stable operation in clean or waste water containing suspended solids or oil and fat.



Options

- Seawater-resistant version;** Galvanic anode & special impeller
- High temperature liquids version;** Max. 60°C
- Special material version;** Made of high-chromium cast iron impeller & suction cover
- Dry pit version;** Available upon request



We reserve the right to change the specifications and designs without prior notice. The OO series and model OO are indicated with our series/model codes in this catalog.

**TSURUMI
MANUFACTURING CO., LTD.**

Your Dealer