

*Original Instructions*

# Multi-Stage Centrifugal Pump MF Series

Pump type:

Pump no.:



## Copyright



© Copyright 2012 Fristam Pumpen KG (GmbH & Co.)

All rights reserved. The contents of this operating manual, including images and design, are subject to the protection of copyrights and other trade-related intellectual property rights. It is not permitted to disseminate or alter the content of this manual. Nor may the said content be copied, disseminated, altered or made available to third parties for commercial purposes.

The original version of this document is the German version.  
All other languages are translations of the original version.

## Table of Contents

<b>1</b>	<b>Introduction</b> .....	5	<b>7</b>	<b>Operation</b> .....	13
1.1	Foreword .....	5	7.1	Safety instructions .....	13
1.2	Manufacturer .....	5	7.2	Starting operation .....	13
1.3	Scope of delivery .....	5	7.3	Monitor the pump operation .....	14
1.4	Scope of documentation .....	5	7.4	Stopping operation .....	14
1.5	About this manual .....	5	7.5	Decommissioning pump .....	14
			7.6	Cleaning during operation .....	14
<b>2</b>	<b>Safety</b> .....	5	<b>8</b>	<b>Malfunctions</b> .....	14
2.1	Basic safety instruction .....	5	8.1	Safety instructions .....	14
2.2	Proper use .....	6			
2.3	Predictable misuse .....	6	<b>9</b>	<b>Maintenance</b> .....	15
2.4	Warning and information signs .....	6	9.1	Safety instructions .....	15
2.5	Noise emission .....	6	9.2	Spare parts .....	15
2.6	Disposal .....	7	9.3	Checking sealing and quenching liquids (optional) .....	15
<b>3</b>	<b>Design and function</b> .....	7	9.4	Lubricating motor bearing .....	15
3.1	Principal design .....	7	9.5	Lubricating shaft seals .....	15
3.2	Pump models .....	8	9.6	Changing motor .....	16
3.3	Pump designation key .....	9	9.7	Replace shaft seal. ....	17
3.4	Versions .....	9	9.8	Dismantle the pump head. ....	17
<b>4</b>	<b>Transport</b> .....	9	9.9	Dismantle the pump head. ....	18
4.1	Transport .....	9	9.10	Model L: Changing coupling .....	21
<b>5</b>	<b>Storage</b> .....	10	<b>10</b>	<b>Appendix 1</b> .....	22
5.1	Safety instructions .....	10	10.1	Technical data .....	22
5.2	Storage conditions .....	10	10.2	Maintenance intervals .....	22
5.3	Storage .....	10	10.3	Troubleshooting .....	23
5.4	Re-commissioning .....	11	10.4	Numbers in sectional drawings .....	25
			10.5	EC Declaration of Conformity .....	26
<b>6</b>	<b>Installation</b> .....	11			
6.1	Safety instructions .....	11			
6.2	Installation site .....	11			
6.3	Prevention of noise and vibration .....	11			
6.4	Mounting the pump .....	11			
6.5	Electrical connection .....	12			
6.6	Connecting the sealing or quenching fluid line (optional) .....	12			
6.7	Cleaning .....	13			



## 1 Introduction

### 1.1 Foreword

This operating manual describe all sizes, designs and versions of the FM pump series.

For the design, size and version of your pump, please refer to the type plate on your pump and the "Order-related documents" in appendix 2.

### 1.2 Manufacturer

FRISTAM Pumpen KG (GmbH & Co.)

Kurt-A.-Körber-Chaussee 55

21033 Hamburg, Germany

GERMANY

Telephone: +49 (0) 40/7 25 56-0

Fax: +49 (0) 40/7 25 56-166

Email: info@fristam.de

### 1.3 Scope of delivery

The delivery includes:

- Pump with motor = pump unit
- Pipe connection covers
- Optional: Assembly kit
- *Fristam* accessories
- Documentation
- ▶ Check the delivery for completeness and transport damage. If you notice any missing parts or damage, immediately contact *Fristam*.

### 1.4 Scope of documentation

The documentation includes:

- **This operating manual**
  - Tables re. maintenance, lubrication and tightening torques in appendix 1
- **Appendix 2 (enclosed document)**
  - Order-related documents
  - Subvendor documentation (motor, etc.)
  - Documentation regarding *Fristam* accessories
  - Certificates where applicable (material certificates, etc.)
  - Declaration of conformity

### 1.5 About this manual

Lists are indicated by dashes:

- Part 1
- Part 2

Tasks that must be completed in a specific sequence are numbered:

1. Switch on machine.
2. Switch off machine.

Tasks that do not need to be completed in a specific order are preceded by triangles:

- ▶ Action
- ▶ Action

#### 1.5.1 Safety instructions

##### **⚠ DANGER**

A safety instruction with the signal word "Danger" warns of dangers to persons that can result in death or serious injury.

##### **⚠ WARNING**

A safety instruction with the signal word "Warning" warns of dangers to persons that may result in death or serious injury.

##### **⚠ CAUTION**

A safety instruction with the signal word "Caution" warns of dangers to persons that may result in minor or moderate injury.

##### **NOTICE**

A safety instruction with the signal word "Attention" warns of damage to property.

## 2 Safety

### 2.1 Basic safety instruction

- ▶ Read this operating manual fully before using the pump and keep it available at the pump installation site.
- ▶ Comply with all applicable statutory regulations in the country of use and the internal working and safety regulations.
- ▶ All work described here must be carried out by qualified specialist technicians and with due care.
- ▶ Danger of contamination: Comply with statutory and operational safety regulations when transporting hazardous conveying media.

## 2.2 Proper use

The standard model of the FM pump series is designed for use in the food processing, pharmaceutical and biotechnology industries as well as in CIP process technology.

It is designed for the pumping of liquids with a dynamic viscosity of maximum 500 mPa and a medium temperature of maximum 150°C, whereby the medium may be homogeneous, contain small quantities of other material or some air or gas.

Each pump is designed to customer requirements. The sealing material has been specifically selected for the respective conveying medium. Only the medium for which the pump has been designed may be conveyed with the pump (see "Order-related documents" in appendix 2).

## 2.3 Predictable misuse

The standard model of the FM pump series must not be operated in explosive atmospheres. For such purposes, we offer special explosion-proof models.

If the pump is used for the conveying of media other than those for which it has been designed, the pump or other equipment might be damaged. There is also a risk of injury to persons standing near the pump.

Standard pump units from Fristam are described in this operator's manual. If nonstandard items or extras are installed, the operator assumes the responsibility for operation.

Modifications and changes to the pump are only permissible with the explicit consent of Fristam.

## 2.4 Warning and information signs

- ▶ Never remove or change the warning and information signs attached to the pump.
- ▶ Replace damaged or missing signs without delay.

### 2.4.1 Hot surface



Fig. 1 Safety sign: "Hot surface"

This safety sign indicates that parts may become hot during pump operation or that hot conveying media may be conveyed. The pump may only be touched with suitable protective gloves.

### 2.4.2 No dry running

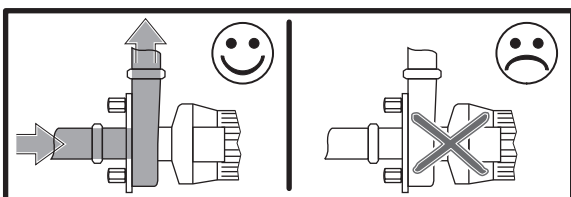

Fig. 2 Safety identification: "No dry running"

This sign indicates that the pump must not be run dry under any circumstances. Conveying medium must always be present in the suction line and the pump when the pump is actuated. Otherwise the pump will be damaged.

### 2.4.3 Direction of rotation



Fig. 3 Indication of direction of rotation of pump impeller

This sign indicates the direction of rotation of the impeller. It is attached to the front of the pump cover.

### 2.4.4 Type plate

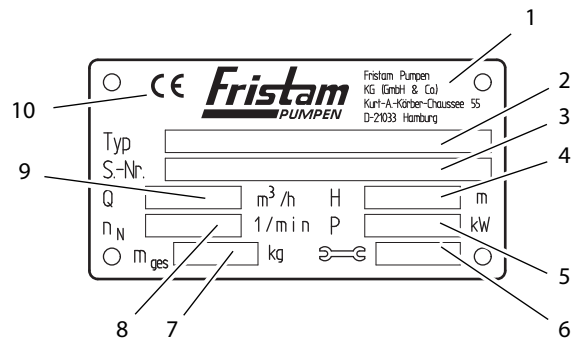

Fig. 4 Type plate

1	Manufacturer
2	Type: Pump series, size, design, version
3	S. No.: Serial number of the pump
4	H: Pump head [m]
5	P: Motor power [kW]
6	Year of manufacture
7	mtot: Mass (total) [kg]
8	n <sub>N</sub> : Rated speed [rpm]
9	Q: Flow rate [m <sup>3</sup> /h]
10	CE Mark

## 2.5 Noise emission

- ▶ Adhere to the applicable statutory regulations for noise emissions. For the noise emission values of the pump, see Chapter 10.1 "Technical data", page 22.

### CAUTION

#### Noise emission when pump is running

Damage to hearing

- ▶ If the sound pressure level of the pump exceeds 80 dB(A), wear hearing protection.

## 2.6 Disposal

### 2.6.1 Disposal of transport packaging

- ▶ Recycle transport packaging as recycling material.

### 2.6.2 Model KF: Disposal of lubricants

- ▶ Dispose of greased components and grease in accordance with the applicable environmental regulations.

### 2.6.3 Models L3V, L4V: Disposal of lubricating oils

- ▶ Dispose of oiled components and oil in accordance with the applicable environmental regulations.

### 2.6.4 Disposal of pump

1. Carefully clean the pump. Dispose of all residue in accordance with the applicable environmental regulations.
2. Dismantle pump into its individual components.
3. Dispose of the pump components in accordance with the applicable environmental regulations.

### 2.6.5 Disposal of electrical and electronic scrap

- ▶ Dispose of electrical and electronic scrap according to the applicable guidelines.

## 3 Design and function

### 3.1 Principal design

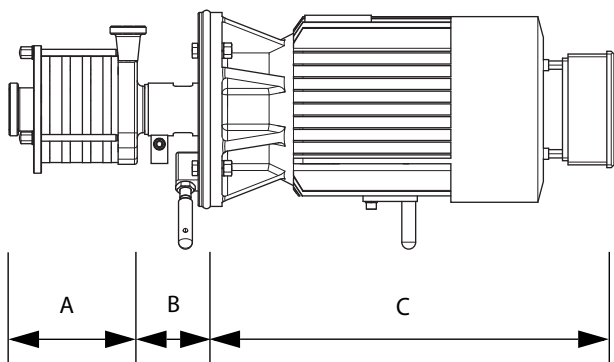

Fig. 5 Principal design of pump illustrated on model F

A	Multi-stage pump head
B	Lantern
C	Electric motor

### 3.1.1 Pump head (A)

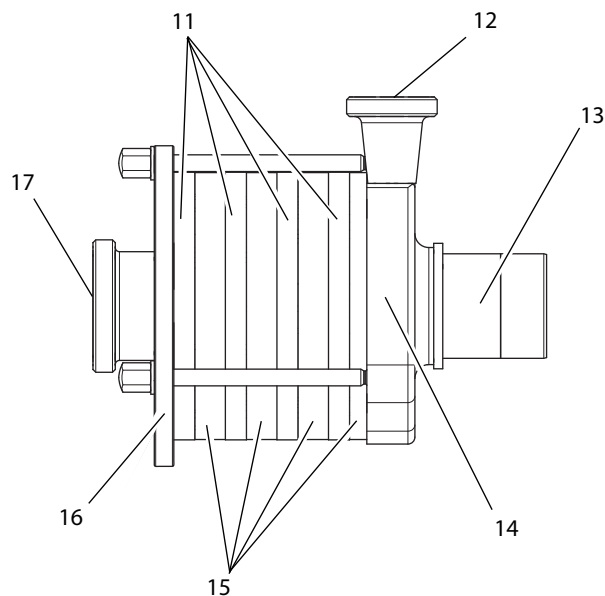

Fig. 6 Pump head

11	Impellers, enclosed in stage casing
12	Pressure line connection
13	Shaft seal
14	Pump casing
15	Stage casing
16	Pump cover
17	Suction line connection

#### Impeller (11)

The following impeller types FM pump series are installed as standard in the pumps:

Model	Impeller version	
	Impeller in pump casing	Impellers in stage casing
FM2	Half-closed, with flush bore	half-closed
FM3	Open, with flush bores	open
FMG3	Closed, with flush bores	closed,
FMS3	Closed, with flush bores	closed
FM4	Open, with flush bores	half-closed

Table 1 Impeller design

Each pump may contain up to 5 impellers.

#### Shaft seal (13)

The pump is available with two different shaft seal types:

- Simple shaft seal
- Double shaft seal

For double shaft seals, the pump casing must feature two additional connections for the sealing liquid. These connections are not shown in the figures below.

**Pump casing (14)**

The pressure line connection is located on the pump casing. The pump casing encases the impeller with flush bore and the shaft seal.

**Stage casing (15)**

The pressure of the medium is increased in the stage casing.

**Pump cover (16)**

The suction line connections is located on the pump cover.

**3.1.2 Lantern (B) and electric motor (C)**

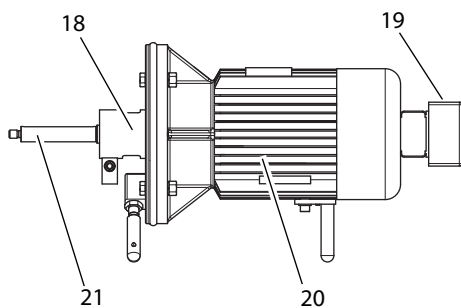

Fig. 7 Lantern and electric motor

18	Lantern
19	Electric power connection
20	Electric motor
21	Pump shaft

**Lantern (18)**

The lantern connects the pump casing with the motor. The lantern comes in two versions, depending on the pump model:

- FM3, FMG3, FMS3 and FM4: The pump casing is screwed to the lantern by means of a flange connection.
- FM2: The pump casing is inserted into the lantern and clamp-fitted.

The following models include a shaft bearing:

- KF: An additional bearing for the pump shaft is fitted inside the lantern with base.
- L: An additional bearing for the pump shaft is fitted inside the lantern with base. The pump shaft is connected to the motor via a coupling.

**Electric motor (20)**

The following motor types can be mounted:

- IEC standard motor with drive side fixed bearing (A side), feather key and shaft pin of the following types:
  - IM B3: Motor design with base
  - IM B5: Motor design with flange

- IM B3/5: Motor design with flange and base
- Special motor with *Fristam* pump shaft

In pumps with a special motor, the *Fristam* pump shaft is factory-mounted and permanently attached to the motor.

**3.2 Pump models**

The model is specified on the type plate, see *Chapter 2.4 "Warning and information signs", page 6.*

The following models are depicted in this manual:

- lantern clamp-fixed,
- without enclosure, see *Chapter 3.4 "Versions", page 9.*

**3.2.1 Model FM2**

**FM2 with special motor**

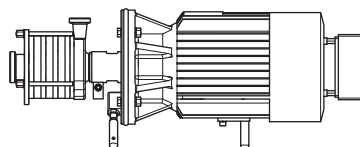

Fig. 8 FM2 with special motor

Motor: Special motor  
Lantern: with clamp connection

**FM2 KF**

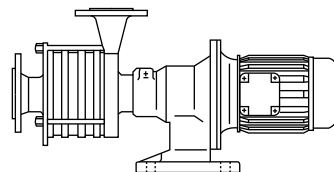

Fig. 9 FM2 KF

Motor: IEC standard motor, model B5  
Lantern: Compact bearing holder with base

**3.2.2 Models FM3, FMG3, FMS3, FM4**

**FM3, FMG3, FMS3 and FM4 with special motor**

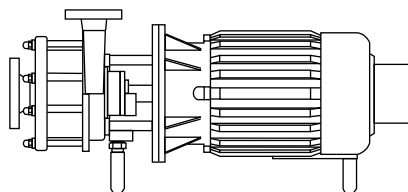

Fig. 10 Models FM3, FMG3, FMS3 and FM4 with special motor

Motor: Special motor  
Lantern: with flange connection



### FM3 L, FMG3 L, FMS3 L, FM4L

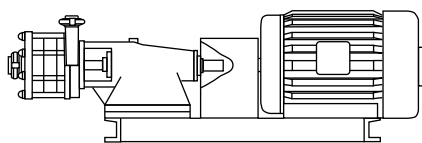

Fig. 11 Models FM3 L, FMG3 L, FMS3 L, FM4L

Motor: IEC standard motor, model B3  
 Design: Bearing block with coupling, coupling protection, base frame

### 3.3 Pump designation key



Fig. 12 Example of type designation

22	Pump type
23	Number of impellers
24	Speed range
25	Suffix

#### (22) Pump type

- FM2 Half-closed impellers, stage casing with open guide vanes
- FM3 Open impellers, stage casing with closed guide vanes
- FMS3 Closed impellers, stage casing with closed guide vanes
- FMG3 Closed impellers, stage casing with spiral guide
- FM4 Half-closed impellers in stage casing, open impeller in pump casing, stage casing with open guide vanes

#### (24) Speed range

- 1 Slow impeller  
Speed range: 1450 rpm at 50 Hz
- 2 Fast impeller  
Speed range: 2900 rpm at 50 Hz

#### (25) Suffix

- A, B, C, D Versions, see Chapter 3.4 "Versions", page 9:
- KF Compact bearing holder with base
- L3V, L4V Bearing block with coupling

### 3.4 Versions

Version	Enclosure	Spherical cap bases	Motor base
A	with	with	without
B	without	without	with
C	without	with	without
D	with	without	with

Table 2 Versions

## 4 Transport

### 4.1 Transport

All transport tasks must be carried out by trained personnel. The pump can be transported by forklift truck or by crane. Always transport the pump in its installation position.

#### 4.1.1 Safety instructions

- ▶ Risk of injury from falling or unsecured components.
  - Only use suitable transport and hoisting equipment. For the weight of the pump, see the type plate and the "Order-related documents" in appendix 2.
  - Prior to transport, secure the pump against falling. Secure it to a pallet, using securing straps or screws.
  - Do not leave the pump in an suspended position for longer than is necessary.
- ▶ Damage to the pump due to contamination, impacts or moisture.
  - Remove the protective foil only immediately prior to installation.
  - Only remove the pipe connection seals immediately prior to connecting the pipes.

#### 4.1.2 Transportation with forklift truck

##### Preparation

- ▶ Ensure that the pump is properly secured on the pallet.

##### Procedure

1. Pick up the pallet with the forks of the forklift truck.
2. Carefully transport the pallet to the intended location and lower it to the ground.

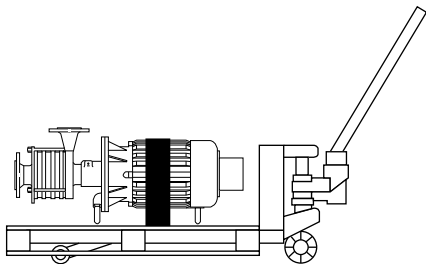

Fig. 13 Transport with lifting equipment

#### 4.1.3 Transport with crane

##### **⚠ WARNING**

##### Falling parts

Death due to crushing, crushing of limbs, damage to property.

- ▶ Do not lift the pump by the eyelet bolts on the motor or the pump casing, as these bolts are not designed to carry the unit weight.
- ▶ Only use hoisting equipment designed for the total weight of the pump.
- ▶ Ensure that there are no persons standing below the suspended the pump.

##### **⚠ WARNING**

##### Swinging parts

Risk of crushing and serious injury.

- ▶ While transporting the pump, start and stop the crane without jerking.
- ▶ Ensure that there are no persons in the danger zone of the pump.

##### Auxiliary equipment

Tested round slings conforming to DIN EN 1492-1 and 1492-2.

##### Preparation

- ▶ Remove transport safeguards.

##### Procedure

1. Loop the round sling twice around the rear end of the motor. Do not loop the sling across the fan cover, see Fig. 14 Transport by crane.
2. Place the other end of the round sling between the lantern and the pump casing. Do not loop the round sling over sharp corners or edges.
3. Bring both slings to the crane hook and rotate them by 180° so that the slings cannot slip in the hook.
4. For models with double shaft seal:

**Caution:** The round sling might push down on the sealing water tube. This might damage the double shaft seal.

- ▶ Ensure that the round sling is placed around the sealing water tube.

5. Position the centre of gravity so that the pump is lifted in a horizontal position.
6. Lift the pump.

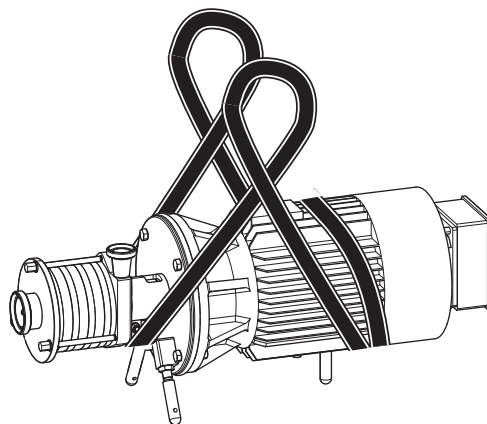

Fig. 14 Transport by crane

## 5 Storage

### 5.1 Safety instructions

- ▶ Corrosion: There is a risk of condensation under the tarpaulin, which can destroy the pump.
  - Provide adequate ventilation.
  - Do not cover the pump with a tarpaulin.

### 5.2 Storage conditions

- ▶ Store the pump as follows:
  - in dry room, with low air humidity
  - protected against frost and heat, where possible at 20 to 25°C
  - in well ventilated area
  - free of dust

### 5.3 Storage

If the pump is to be stored for a period of more than six months, comply with the following:

- ▶ Remove the shaft seals and store them separately.
  - **For models with single shaft seal:**  
Loosen the impeller nut to release the seal and prevent adhesion of the elastomers.
  - **For models with double shaft seal:**  
Remove the entire shaft seal and store it separately to prevent adhesion of the elastomers.

For more information regarding the shaft seal, see "Order-related documents" in *appendix 2*.

- ▶ All moving pump parts must be rotated every three months.

### 5.3.1 Storage of elastomer parts

Storage conditions

- Storage temperature between +5°C and +20°C
- relative air humidity below 70%
- protected from direct sunlight
- stored in a manner that does not cause deformation

## 5.4 Re-commissioning

- ▶ Prior to re-commissioning after prolonged storage, check the seals, bearings and lubrication.

# 6 Installation

## 6.1 Safety instructions

- ▶ Risk of injury from falling parts.
  - Wear safety footwear.
  - Observe the load-bearing capacity of the hosting equipment and ensure proper attachment.
- ▶ Risk of injury from unstable installation:
  - Tighten the screws with prescribed torque, see *Chapter 10.1.1 "Tightening torques for screws and nuts", page 22.*
  - Use a torque wrench or a impact screwdriver with adjustable torque.
- ▶ Risk of damage to property from vibration in machines with spherical cap bases:
  - Use spherical cap discs.

## 6.2 Installation site

The installation site for pumps with standard equipment must meet the following conditions:

- Non-explosive atmosphere.
- Dust-free environment.
- Ambient temperature: -20°C to +40°C
- Moisture and salt content of ambient air: see specifications in motor manufacturer documentation in appendix 2.
- Foundation of adequate dimensions for the pump weight.
- Horizontal and level installation surface. Adequate strength of surface for the pump weight.
- Sufficient space for maintenance work also required.
- Sufficient air supply for motor cooling.

## 6.3 Prevention of noise and vibration

### 6.3.1 Primary measures

- ▶ Operate pump within optimum operating range:
  - Do not underload the pump. Avoid excessive throttling. Only operate the pump with a low flow rate, if this is necessary for regulating purposes.
  - Do not operate the pump with very high flow rates. If necessary, install flow restrictors in the pressure line.
  - Operate the pump without cavitation, see *Chapter 6.4.1 "Installing the pipelines", page 12.*
- ▶ De-couple the suction and pressure lines from vibrating parts:
  - Support the lines.
  - Align the lines.
  - Use vibration insulation elements.

### 6.3.2 Secondary measures

- ▶ Implement structural measures, such as:
  - Sound-proof cladding
  - Encasing of pump

## 6.4 Mounting the pump

### Models FM2, FM3, FMG3, FMS3, FM4

- ▶ Versions A and C:  
Install and align the pump on the spherical cap bearings.
- ▶ Versions B and D:  
Screw the pump with the pump base to the foundation.

### Model KF:

- ▶ Versions A and C:  
Install and align the pump on the spherical cap bearings.
- ▶ Versions B and D:  
Screw the pump at the compact bearing holder with the base to the foundation.

### Model L

- ▶ Versions A and C:  
Install and align the pump on the spherical cap bearings.
- ▶ Versions B and D:  
Screw the pump with the pump frame to the foundation.

### Mobile frame

1. Position the pump at its location of operation. Apply the brakes to the rollers (if available) or secure the mobile frame with chocks.
2. Connect the mobile frame to an earthing conductor to eliminate static charging.
3. Install the hose in such a way that it cannot be damaged.

### 6.4.1 Installing the pipelines

- ▶ Install and connect the pipelines as follows:
  - Keep the pipeline friction loss as low as possible: Avoid unnecessary valves, elbows, and abrupt pipe transitions.

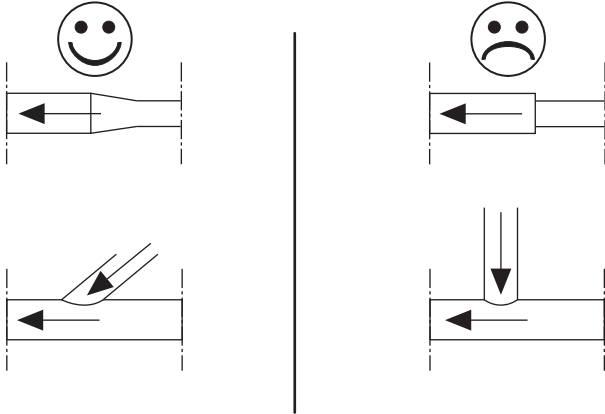

Fig. 15 Pipe transitions

- Install piping with an appropriate cross-section so that there is no unnecessary pressure loss or cavitation in the suction section so that
 
$$NPSH_{unit} > NPSH_{pump}$$
 at all times.
 

This should be checked during the planning stage.
- Install the suction lines in horizontal position or at a constant dropping angle towards the pump unit. Rule out the possibility of air pockets and dips in the pipes.

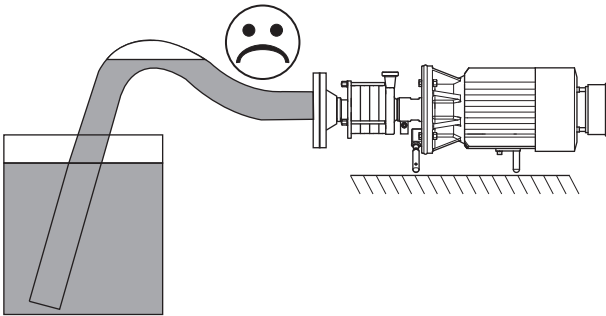

Fig. 16 Air lock

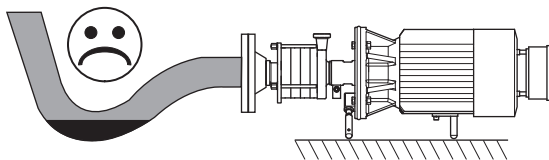

Fig. 17 Dip in pipeline

- Elbow sections in front of suction connection: Observe the minimum distance and minimum radius:

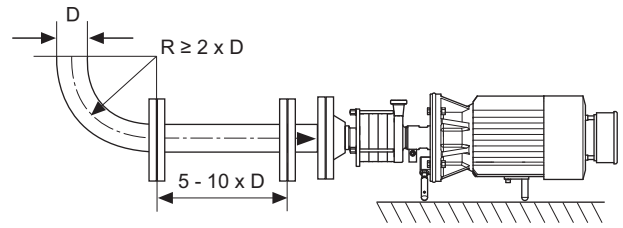

Fig. 18 Installation of suction line

- Dimension the pipeline connections based on pressure, temperature and medium properties.
- Connect the pipelines without strain or pressure to the pump so that there is no stress or torsion at the pump.
- Fasten the pipeline with pipe clamps to ceilings, walls and the floor.
- Align the pipelines so that they are flush to the pump connections.

## 6.5 Electrical connection

The electrical connection must be installed by a qualified electrician.

1. Observe the connection rating on the motor type plate. The specified voltage must not be exceeded.
2. Connect the motor according to the circuit diagram in the terminal box of the motor.
3. Protect the cable glands against moisture.
4. Switch on the motor for 2 to 3 seconds. Compare the actual direction of rotation of the motor fan impeller with the arrow on the pump head.
5. If necessary, switch the poles.

## 6.6 Connecting the sealing or quenching fluid line (optional)

In versions with double shaft seal, the seal chamber must be flushed with a sealing or quenching liquid.

- ▶ Use a suitable medium, such as water, for this purpose.

### 6.6.1 Installing the pipelines

1. Install and seal the supplied flushing tubes.
2. As a standard, the feed line should be fitted at the **bottom** of the shaft seal.
3. As a standard, the return line should be fitted at the **top** of the shaft seal.

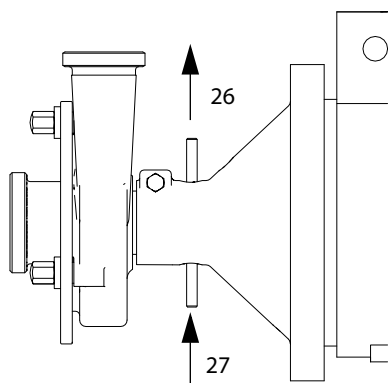

Fig. 19 Installing the pipelines

26	Return line
27	Inlet

4. Install the following valves into the pipelines:
  - Install the sight glass in the return line.

## 6.7 Cleaning

To clean the machine use a detergent that conforms to the hygiene requirements for the respective medium.

1. Before sealing the pump, ensure that there are no foreign substances inside the pump and the pipelines.
2. Screw the pump cover to the pump casing.
3. Connect the pipelines.
4. Before commissioning the machine, clean the pump and the pipeline system thoroughly.

## 7 Operation

### 7.1 Safety instructions

- ▶ Risk of injury from burns: If the pump is used for the conveying of a hot medium, it can become very hot. Before touching the pump, check its temperature.
- ▶ Noise emission: The A-rated sound pressure level of the pump can exceed 80 dB(A). Always wear hearing protection when in the vicinity of the running pump.
- ▶ Risk of rupture: If the permissible pressure or temperature range is exceeded, the pump might rupture or starts leaking. Operate the pump within the permissible pressure and temperature range, see "Order-related documents" in appendix 2.
- ▶ Risk of rupture: In the event of a fire, the use of cold extinguishing agents can cause the pump to rupture. Do not cool the pump when extinguishing, unless necessary.
- ▶ Pump is running in reverse, despite emergency-stop: In the event of an emergency stop, the pump might run in reverse,

due to the medium pressure in the pressure line. If necessary, install a check valve in the pressure line.

- ▶ Reverse running of the pump destroys the shaft seal. Reverse running of the pump destroys the springs in the shaft seal: Always operate the pump in the correct direction of rotation, see Chapter 2.4.3 "Direction of rotation", page 6.

### 7.2 Starting operation

#### NOTICE

#### Damage to the shaft seals

Running the pump without medium results in damage to the mechanical seal.

- ▶ Ensure that there is always sufficient medium in the pump (fill level at top edge at the outlet side) prior to and during operation.

#### NOTICE

#### Damage to double shaft seals

Running the pump without sealing liquid results in damage to the shaft seal.

Ensure that during operation:

- ▶ The sealing liquid flows with the necessary pressure through the double shaft seal.

The prescribed sealing fluid pressure is specified in the "Order-related documents" in the sectional drawing of the shaft seal. The "Order-related documents" are included in this operating manual.

- Negative pressure in the seal chamber is not allowed.

If no pressure is noted in the "Sectional drawing of the shaft seal", the following applies:

- A max. pressure of 0.2 bar is allowed for seals to which sealing fluid is applied without pressure or which are flushed.

- ▶ The temperature of the sealing liquid is maintained at  $T < 70\text{ }^{\circ}\text{C}$ .

1. Open the valve in the suction line.
2. Close the valve in the pressure line.
3. Fill the pump and the suction line up to the top edge of the pump with medium. Allow any air bubbles to escape.
4. Switch on the motor. The pump conveys medium against the closed valve in the pressure line. This limits the start-up current.
5. Slowly open the valve in the pressure line and adjust the working point.

### 7.3 Monitor the pump operation

During operation, pay attention to the following:

- ▶ Damage to the shaft seal: Regulation of the pump performance by means of the valve at the suction side can cause damage to the pump and the shaft seals. Only adjust the pump performance with the valve at the pressure side.
- ▶ Damage to conveying medium: If the valve in the pressure line is suddenly closed during operation, or is closed for a prolonged period of time, pressure blows might occur in the pump, damaging the pump and/or the medium. During pump operation, do not close the valve in the pressure line suddenly or for prolonged periods.
- ▶ Damage to pump: Exceeding the rated pump rate can lead to damage to the pump and the shaft seals. Do not exceed the maximum speed of 3,600 rpm.
- ▶ Damage to motor when operated with frequency inverter (FI): If the speed is too low, the FI motors might become damaged from overheating. Observe the instructions in the motor manufacturer documentation appended to this document.

### 7.4 Stopping operation

1. Switch off the motor.
2. Close the valve in the suction line to prevent the pump from running empty.
3. Close the valve in the pressure line.

### 7.5 Decommissioning pump

1. Switch off the motor.
2. Close the valve in the suction line.
3. Close the valve in the pressure line.
4. Disconnect the pump from the power supply.
5. Empty the pump.
6. Clean the pump.
7. Dry the pump.
8. Protect the interior of the pump against moisture, for example with silica gel.
9. Seal the pipe connections with caps to prevent dirt or foreign objects entering the pump.
10. For further steps, see *Chapter 5 "Storage", page 10*.

### 7.6 Cleaning during operation

#### 7.6.1 CIP method

FM pump series is suitable for the "cleaning in place" (CIP method). The following recommended values apply to CIP cleaning:

#### Sample cleaning sequence

1. Pre-rinse with water.
2. Alkali rinse with sodium hydroxide (NaOH, see *Table 3 CIP cleaning*).
3. Intermediate rinse with water.
4. Acid rinse with nitric acid (HNO<sub>3</sub>, *Table 3 CIP cleaning*).
5. Clear rinse with water.

Medium	Process temperature [°C]
NaOH (approx. 1 - 2%)	80 - 85
HNO <sub>3</sub> (approx. 1 %)	60 - 65

*Table 3 CIP cleaning*

The differential pressure of the pump should be 2 - 3 bar in order to achieve adequate flow rates.

If the above values cannot be achieved, contact *Fristam*.

#### 7.6.2 SIP method

FM pump series are only suitable for "sterilisation on place cleaning" (SIP method) after consultation with *Fristam*.

Suitability depends on the installed elastomers.

The maximum process temperature is 145°C.

In ATEX operation, temperatures might deviate, see supplementary ATEX manual, "Temperature limits".

## 8 Malfunctions

For possible malfunctions and troubleshooting instructions, see *Chapter 10.3 "Troubleshooting", page 23*.

### 8.1 Safety instructions

- ▶ Risk of injury from burns: If the pump is used for the conveying of a hot medium, it can become very hot. Before touching the pump, check the temperature.
- ▶ Pump is running in reverse, despite emergency-stop: In the event of an emergency stop, the pump might run in reverse, due to the medium pressure in the pressure line. Install a non-return valve.

## 9 Maintenance

For maintenance intervals, see *Chapter 10.2 "Maintenance intervals", page 22.*

### 9.1 Safety instructions

- ▶ Rotating parts: risk of injury. Before removing the coupling protection and the motor guard plate, switch off the pump and secure it against restarting.
- ▶ Risk of injury from burns: If the pump is used for the conveying of a hot medium, it can become very hot. Before touching the pump, check its temperature.
- ▶ Electric shock: As liquids flow through the unit, components might become electrically charged. Connect the pipelines and the pump to an earthing conductor.
- ▶ Uncontrolled escaping of liquid: Before any maintenance and set-up work on the pump:
  - Close the suction and pressure valves upstream and downstream of the pump.
  - Close the sealing or quenching liquid line.
- ▶ Escaping liquids: Risk of corrosion and contamination. Before opening the pump casing, empty the pump.
- ▶ Stress fractures: Do not shock-cool the pump. Damage to polished surfaces. For work on polished surfaces, use a socket wrench with copper insert.

### 9.2 Spare parts

- ▶ The use of spare parts other than those approved by *Fristam Pumpen KG (GMBH & Co.)* can result in serious injury and damage to property. If you have any queries regarding approved spare parts, contact *Fristam*.
- ▶ *Fristam* registers all shipped pumps. When ordering spare parts from *Fristam*, please submit the following information
  - Serial number, see
    - type plate or
    - pump casing (stamped mark)

### 9.3 Checking sealing and quenching liquids (optional)

For pumps equipped for "locking system" or "quenching system," the sealing liquid head must be checked daily.

- ▶ Measure the sealing liquid pressure and compare it with the prescribed value.
 

The prescribed pressure is specified in the "Order-related documents" in the *sectional drawing* of the shaft seal. The "Order-related documents" are included in *appendix 2* of this operating manual.
- ▶ The sealing liquid in the pump is heated up by the hot conveying medium.

During operation, ensure that the sealing liquid temperature is  $T < 70^{\circ}\text{C}$ .

### 9.4 Lubricating motor bearing

- ▶ Lubricate the motor bearings according to the instructions of the motor manufacturer, see "*Motor manufacturer documentation*".

### 9.5 Lubricating shaft seals

Models FM2, FM3, FMG3, FMS3 and FM4 do not include an additional shaft seal and therefore do not need lubrication.

#### 9.5.1 Models L3V, L4V:

Regularly change the oil.

1. Switch on the motor and let it run until the pump has reached its operating temperature.
2. Switch off the motor and secure it against restarting.
3. Place a suitable oil collecting container under the oil drain screw.
4. **Caution!** Risk of injury from hot oil.
  - ▶ Wear suitable protective gloves.
  - ▶ Remove the oil drain screw.
5. Drain off all oil and dispose of it according to the applicable statutory regulations.
6. Clean the oil drain screw and re-insert it.
7. Add new oil until the level reaches the centre of the oil sight glass. We recommended using the: SAE 15W40 oil type. Alternatively, use an equivalent brand of lubricant of similar quality and viscosity. For oil quantities, see *Table 4 Oil quantity*.

Type:	Oil quantity
L3V	approx. 3 litres
L4V	approx. 4 litres

*Table 4 Oil quantity*

#### 9.5.2 Model KF

- ▶ Do not lubricate the grooved ball bearing. If required, replace grooved ball bearing.
- ▶ Lubricate cylindrical roller bearing with bearing grease.

Model	Bearing grease quantity
KF 2	40 g

*Table 5 Bearing grease quantities for model KF*

#### Preconditions

- Pump head is removed.
- Motor is dismantled.

**Procedure**

1. Remove the bearing cover (30).
2. Push the pump shaft (28) together with the bearing towards the motor side to remove it.

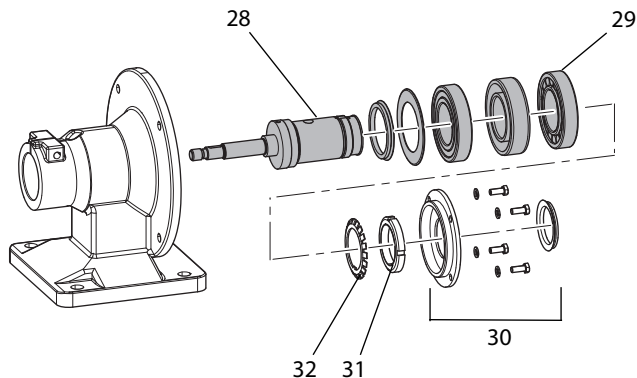

Fig. 20 Model KF, shaft bearing

3. Remove the bearing nut (31) and the retaining washer(32).
4. Remove the outer race of the cylindrical roller bearing.  
*Note: All components shown in grey in the above figures remain mounted on the pump shaft.*
5. Clean all parts and inspect them for damage. If necessary, replace damaged parts.
6. Lubricate the cylindrical roller bearing (29), see Table 5 Bearing grease quantities for model KF. We recommended using: JAX Halo-Guard FG-2 bearing grease or alternatively a white NSF H1 grease. Alternatively, use an equivalent brand of lubricant of similar quality and viscosity.
7. Mount the outer race on the pump shaft (28).
8. Place the retaining washer and the bearing nut on the pump shaft and tighten the bearing nut.
9. Push the pump shaft together with the bearing into the lantern.
10. Mount the bearing cover (30).

**9.6 Changing motor**

**Special motor**

1. Switch off the motor and secure it against restarting.
2. Remove the pump head, see Chapter 9.8 "Dismantle the pump head.", page 17.
3. **WARNING:** The motor might become dislodged. Risk of damage to equipment and serious injury from crushing.  
▶ Before loosening the screws, secure the motor.
4. Loosen the screws securing the lantern to the motor.
5. Remove the guard plates, if installed.
6. Loosen the screws connecting the motor flange to the lantern.

7. Remove the lantern.
8. Replace the special motor.
9. If required, replace the mechanical seal and mount the pump head, see Chapter 5. "Check the oil level and add oil, if necessary.", page 20.

**IEC standard motor in model KF**

1. Switch off the motor and secure it against restarting.
2. **WARNING:** The motor might become dislodged. Risk of damage to equipment and serious injury from crushing.  
▶ Before loosening the screws, secure the motor.
3. Before loosening the screws, secure the motor.
4. Remove the motor from the compact bearing holder with base.
5. Dispose of the motor according to the applicable statutory regulations, see Chapter 2.6.5 "Disposal of electrical and electronic scrap", page 7.
6. Insert the key of the old motor in the new motor.
7. Secure the motor to the compact bearing holder with base.

**IEC standard motor in model L**

*Note: For information on the coupling, see coupling subvendor documentation in the appended documentation.*

1. Switch off the motor and secure it against restarting.
2. Remove the coupling guard.
3. Remove the motor from the base frame or foundation.
4. Remove the coupling parts from the motor.
5. Dispose of the motor according to the applicable statutory regulations, see Chapter 2.6.5 "Disposal of electrical and electronic scrap", page 7.
6. Mount the coupling parts on the new motor (for coupling change, follow the instructions in Chapter 9.10 "Model L: Changing coupling", page 21).
7. Place the new motor on the base from or foundation.
8. Check the centre offset and the angle offset of the shaft.

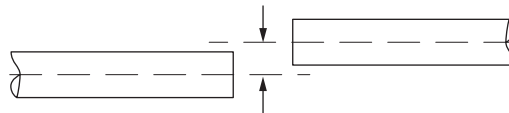

Fig. 21 Centre offset

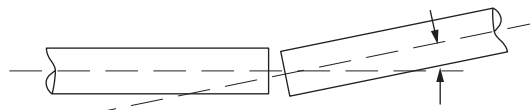

Fig. 22 Angle offset

9. Keep the angle and centre offset deviations as small as possible. If necessary, re-align the shaft.
10. Screw the motor to the base frame or foundation.
11. Mount the coupling guard.



## 9.7 Replace shaft seal.

The shaft seal must be replaced, if:

- Medium escapes from the pump at the atmosphere side
- Sealing liquid contaminates the conveying medium

### Procedure

1. Remove the pump head, see *Chapter 9.8 "Dismantle the pump head.", page 17.*
2. If required, replace the mechanical seal and mount the pump head, see *Chapter 5. "Check the oil level and add oil, if necessary.", page 20.* Perform the following steps, depending on the shaft seal type:
  - ▶ Pre-assemble the seals on the shaft.
  - ▶ Pre-assemble the pump casing.
  - ▶ Mount the lantern on the pump casing.
  - ▶ Mount the mechanical seal.
  - ▶ Mount the impellers and the stage casing.
  - ▶ Screw on the pump cover.

## 9.8 Dismantle the pump head.

### Preparation

1. Switch off the motor and secure it against restarting.
2. Close the valve in the pressure line.
3. Close the valve in the pressure line.
4. **Caution:** When conveying hazardous media, strictly adhere to the statutory and internal safety regulations.
5. Remove the pump from the unit.

### 9.8.1 Dismantle the pump head.

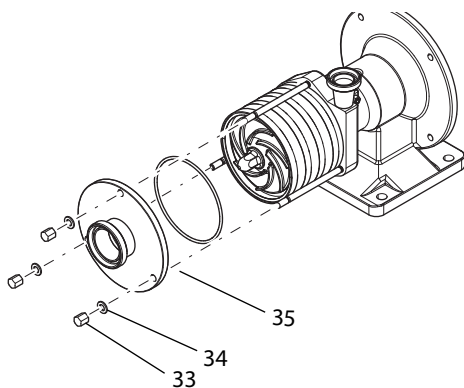

Fig. 23 Removing the pump cover (example of model FM2)

1. Loosen the nuts (33) from the pump cover (35).
2. Remove the nuts, washers (34) and the pump cover.
3. Empty and clean the pump.

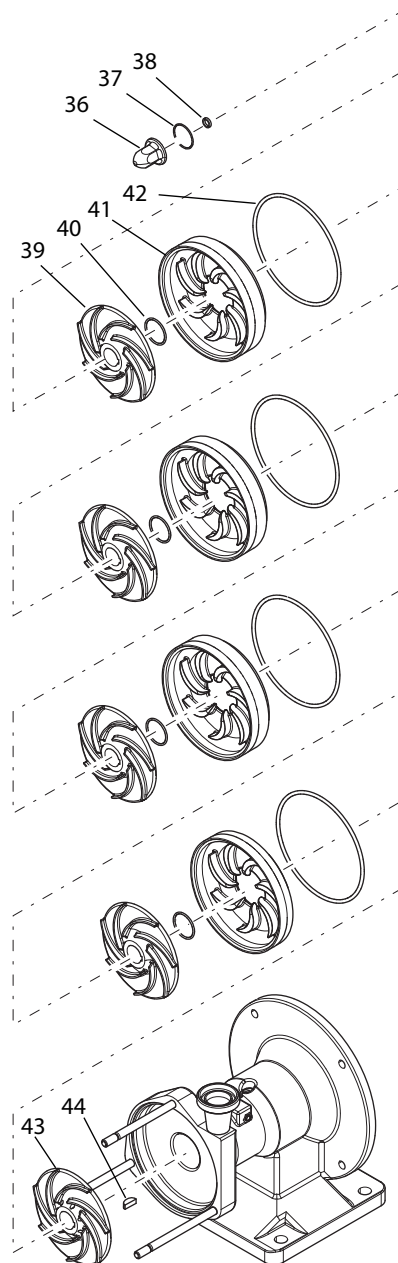

Fig. 24 Impellers and stage casing (example of model FM2)

4. **WARNING:** Risk of injury when holding the impeller by hand to prevent it from rotating.
  - ▶ Block the front impeller (39) with a timber wedge.
5. Loosen the impeller nut (36) and remove it with the O-ring (37).
6. Remove the snap ring (38) from the shaft.
7. Remove the front impeller and the O-ring (40) from the shaft.
8. Remove the stage casing (41) and the O-ring (42) from the shaft.

In models FM3 and FM4, also remove the spacer bushing from the shaft. See also sectional drawing, parts no. (525) in the enclosed documentation.

9. Repeat step (5.), step (7.) and step (8.) until all stage casings are removed from the shaft.
10. Remove the impeller (43) (from pump casing).
11. Remove the key (44).
12. Clean all dismantled components.
13. Remove the front section of the shaft seal (stationary seal ring). See sectional drawing of shaft seal in the "Order-related documents".
14. Only in pumps with double shaft seal: Remove the flush tube for the sealing/quenching liquid.

*TIP: Large pump casings are equipped with an M 12 thread at the top. This thread is provided to insert an eyelet bolt for the attachment of the pump head to a crane.*

15. Pull the pump head together with the pump-side shaft seal from the shaft, proceeding as following:

15a. Version with clamp connection

1. Loosen the clamp screw.
2. Slightly widen the clamp connection with a wedge.
3. Pull the pump casing from the clamp connection.

15b. Version with flange connection

**FM3, FMS3, FMG3 and FM4**

1. Remove the guard plates.
2. Loosen and remove the connecting screws at the flange.
3. Remove the pump casing.

16. Remove the shaft seal from the pump casing.

For shaft seal, see sectional drawing of shaft seal in the "Order-related documents".

- ▶ Clean the sealing faces of the mechanical seals with a degreasing agent, e.g. "OKS 2610 Universal Cleaner". Ensure that the seal faces are subsequently not contaminated with oil or grease. Do not touch them with your fingers.

*Tip: To secure the bearings and bushings, we recommend using an adhesive such as "Euro Lock A64.80".*

*Tip: To secure the threaded pins, we recommend using an adhesive such as "Euro Lock A24.10".*

**9.9.1 Adjusting clearance**

*Note: The clearance must be measured and re-adjusted each time the impellers are mounted.*

The positions of the impellers are determined by their positions on the shaft. The clearance can be adjusted by changing the position of the pump casing.

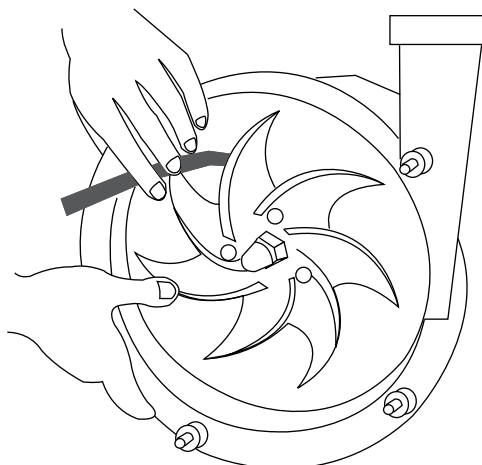

Fig. 25 Clearance between impeller and pump casing

Adjust the clearance according to Table 6 "Clearance", page 18.

Pump size	Clearance last impeller / pump casing [mm]
FM2	0.9 - 1.1
FM3	0.9 - 1.1
FM4	0.9 - 1.1
FMG3	0.9 - 1.1
FMS3	1.9 - 2.1

Table 6 Clearance

**9.9 Dismantle the pump head.**

To mount the pump head, refer to the sectional drawings in the enclosed documentation,

**Incorrect elastomers**

Leakage at pump.

- ▶ Ensure that the elastomers are suitable for the conveying medium, see "Order-related documents".

**Preparation**

- ▶ Clean all pump parts and inspect them for damage and proper fit.
- ▶ If required, rework or replace the pump parts.
- ▶ All parts must be mounted under clean conditions and without applying excessive force, as seals might become permanently deformed or might even break.
- ▶ Replace all O-rings.
- ▶ To reduce friction, wet the O-rings and sliding surfaces with water, alcohol or silicone grease.

**Tightening torques for screws**

Thread	Tightening torques for impeller nut
M16	100 Nm
M24	200 Nm

Table 7 Tightening torques for impeller nut

	Thread	Tightening torques for clamp connection
Special motor	M10	36 Nm
Standard motor	M10	45 Nm
	M12	75 Nm

Table 8 Tightening torques for clamp connection

For all other tightening torques, see Chapter 10.1.1 "Tightening torques for screws and nuts", page 22.

## 9.9.2 Seals

For details regarding the shaft seal installed in the pump, see "Order-related documents", sectional drawing and spare parts list.

## 9.9.3 Assembly of model FM2

Prior to assembly, measure the clearance between the impeller and the casing and re-adjust it, if necessary.

### Preparation for clearance adjustment

- Slide the pump casing with the shims into the clamp connection so that the pump casing and the shims are flush with the clamp connection.
- Push the shaft sleeve (seal driver) onto the pump shaft. Position the components as shown in the sectional drawing in the "Order-related documents".
- Insert the key, slide all impellers onto the pump shaft and tighten the impeller nuts.

### Measuring clearance

- Measure the clearance between the pump casing and the impeller. See Fig. 25 "Clearance between impeller and pump casing", page 18.
- Compare the measured value with that in the table.

### Adjusting clearance

Clearance too small:

- ▶ Reduce shim size.

Clearance too large:

- ▶ Replace shim or place a spacer ring between the pump casing and the shim. For the position of the spacer ring and ship, see sectional drawing.

The other impellers do not need to be adjusted.

### Assembly after clearance measurement

After the clearance has been measured and adjusted, the pump can be assembled. To do this, you must first dismantle the pump again.

The assembly procedure differs:

- based on the model (A, B, C, D or KF respectively)
- for single and double shaft seals

For details, see "Order-related documents".

- Mount the lantern on the special motor.
- Mount the shaft seal (part 1):
  - For models with single shaft seal:
    - ▶ Install the stationary seal ring in the pump casing.
  - For models with double shaft seal:
    - Secure the shaft protective sleeve to the pump shaft.
    - Press the radial gasket into the pump casing (drive side).
    - Install the stationary seal ring in the pump casing (product side).
- Slide the pump casing with the shim into the clamp connection and tighten the clamp screw, see Table 8 "Tightening torques for clamp connection", page 19.
- Mount the shaft seal (part 2):
  - ▶ Slide the front, moving shaft seal kit onto the pump shaft.
- Insert the key.
- Mount the impellers and the stage casing in the sequence of their numbers.
- Slide the slit snap ring onto the pump shaft and tighten the impeller nut, see Table 7 "Tightening torques for impeller nut", page 18.

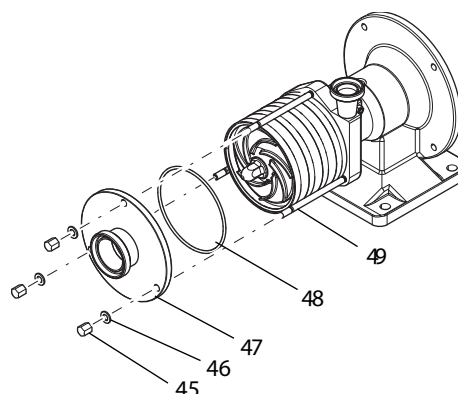

Fig. 26 Mounting the pump cover (example of model FM2)

- Place the pump cover (47) with the seal (47) onto the stage casing (48).
- Secure the pump cover with the nuts (45) and the washer (46) to the stage casing.
- For model KF only: install motor
  - Place the supplied plastic key in the motor bearing journal.
  - Screw the motor onto the compact bearing holder.
- Caution:** Rotating parts. Risk of injury and damage to property.
  - ▶ Before restarting the pump, ensure that all guard plates are properly secured.

### 9.9.4 Assembly for models FM3, FMG3, FMS3 and FM4

Prior to assembly, measure the clearance between the impeller and the casing and re-adjust it, if necessary.

#### Preparation for clearance adjustment

1. Secure the casing without shaft seal to the lantern or the bearing block.
2. Slide the fixed bushing and the shaft sleeve of the shaft seal (see *sectional drawing of shaft seal* in the "Order-related documents") onto the pump shaft.
3. Slide all impellers with the matching spacer bushings onto the pump shaft and tighten the impeller nut.

#### Measuring clearance and comparison with values in the table:

1. Measure the clearance between the impeller and the pump casing with a feeler gauge, see *Fig. 25 "Clearance between impeller and pump casing", page 18*.
2. Compare the measured value with the reference values in table *Table 6 "Clearance", page 18*.

#### Adjusting clearance

- too small: change fixed bushing
- too large: reduce fixed bushing size

It is normally not necessary to adjust the clearance of the other impellers.

Should one of the front impellers be obstructed, change the fixed bushing or adjust its height accordingly.

#### FM3 and FMS3: Replacement of race pressed into stage casing

The race must only be replaced if there are signs of wear or damage.

1. **Caution:** Risk of damage to property. Do not drive out the race with a hammer.
  - ▶ Carefully push the race from the stage casing.
2. Degrease the stage casing recess.
3. Degrease the race.
4. Apply and adhesive (e.g. "Euro Lock A64.80" from Loctite, type 648) to the recess of the stage casing.
5. Press the race into the stage casing so that the large bevel faces outwards.

#### Assembly of FM3, FMG3 and FMS3 after clearance measurement

After the clearance has been measured and adjusted, the pump can be assembled. To do this, you must first dismantle the pump again.

The assembly procedure differs:

- based on the model (A,B, C or D respectively)
- for single and double shaft seals

For details, see "Order-related documents".

1. Mount the shaft seal (part 1):

For models with single shaft seal:

1. Install the stationary seal ring in the sealing cover.
2. Screw the sealing cover with the new flat seal to the pump casing, see *Chapter 10.1.1 "Tightening torques for screws and nuts", page 22*.

For models with double shaft seal:

1. Secure the shaft protective sleeve to the pump shaft.
2. Press the radial seal ring into the rear sealing cover (drive side).
3. Install the stationary seal ring in the front sealing cover (product side).
4. Screw both sealing covers with the new flat seals to the pump casing, see *Chapter 10.1.1 "Tightening torques for screws and nuts", page 22*.

2. Screw the flange connection to the pump casing.

3. Mount the shaft seal (part 2):

- ▶ Slide the movable front shaft seal kit with the shaft sleeve and the fixed bushing onto the pump shaft.

4. Insert the key into the bearing journal.

5. **Caution:** Risk of damage to property. For each mounted impeller, check whether the impeller chafes at any point.

- ▶ Mount the impellers, the bushings and the stage casing in the sequence of their numbers.

6. Slide the slit snap ring onto the pump shaft and tighten the impeller nut, see *Table 7 "Tightening torques for impeller nut", page 18*

7. Place the cover with the seal on the casing and tighten the screws.

8. For bearing block model only:

1. Secure the bearing block with screws to the base frame.
2. Install the coupling between the bearing block and the motor and align them (follow instructions in "Order-related documents").
3. Secure the motor with screws to the base frame.
4. Mount the coupling guard.
5. Check the oil level and add oil, if necessary.

9. **Caution:** Rotating parts. Risk of injury and damage to property.

- ▶ Before restarting the pump, ensure that all guard plates are properly secured.

#### FM4: Assembly of FM4 after clearance measurement

After the clearance has been measured and adjusted, the pump can be assembled. To do this, you must first dismantle the pump again.

The assembly procedure differs:

- based on the model (A,B, C or D respectively)
- for single and double shaft seals

For details, see "Order-related documents".

1. Mount the shaft seal (part 1):
  - ▶ Install the stationary seal ring in the pump casing.

For models with double shaft seal:

1. Secure the sealing cover to the pump casing with the round seal see *Chapter 10.1.1 "Tightening torques for screws and nuts"*, page 22.
2. Secure the shaft protective sleeve to the pump shaft.
3. Press the radial seal ring into the rear sealing cover (drive side).

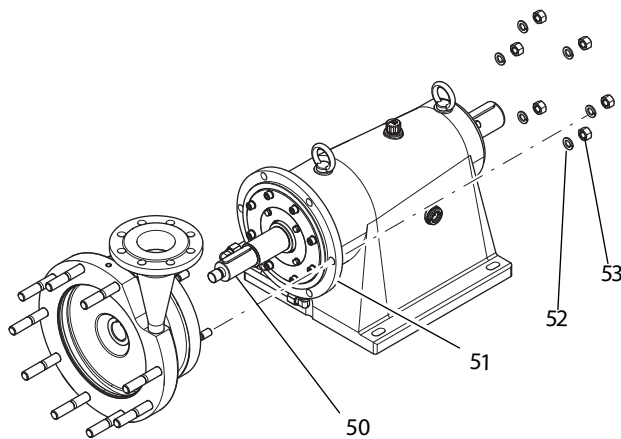

Fig. 27 Model FML4V: Mounting pump casing

2. **Caution:** Improper assembly can cause damage to the mechanical seal.
  - ▶ Carefully slide the pump casing over the shaft (50).

3. Secure the pump casing to the flange (51), using the washers (52) and nuts (53).

4. Mount the shaft seal (part 2):
  - ▶ Slide the movable front shaft seal kit with the shaft sleeve and the fixed bushing onto the pump shaft.

5. Insert the key into the bearing journal.
6. Mount the impellers, the bushings and the stage casing in the sequence of their numbers.

Note: For each mounted impeller, check whether the impeller chafes at any point.

7. Slide the slit snap ring onto the pump shaft and tighten the impeller nut, see *Table 7 "Tightening torques for impeller nut"*, page 18.

8. Place the cover with the seal on the casing and tighten the screws.

9. For bearing block model only:

1. Secure the bearing block with screws to the base frame.
2. Install the coupling between the bearing block and the motor and align them (follow instructions in "Order-related documents").
3. Secure the motor with screws to the base frame.
4. Mount the coupling guard.

5. Check the oil level and add oil, if necessary.

10. **Caution:** Rotating parts. Risk of injury and damage to property.

Before restarting the pump, ensure that all guard plates are properly secured.

## 9.10 Model L: Changing coupling

Use only couplings that have been approved by *Fristam*. The coupling must match the characteristic of the pump. If you have any queries, contact *Fristam*.

### Procedure

1. Switch off the motor and secure it against restarting.
2. Remove the coupling guard.
3. Remove the coupling belt.
4. Remove the motor from the base frame or foundation.
5. Dispose of the coupling parts according to the statutory regulations.
6. Mount the new coupling parts (belt, flanges, clamping rings, etc.) on the drive shaft and the gear shaft.
7. Place the motor on the base frame or foundation and slightly tighten the mounting screws.
8. Check the centre offset and the angle offset of the shaft.

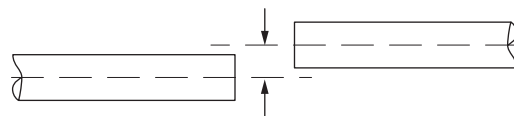

Fig. 28 Centre offset

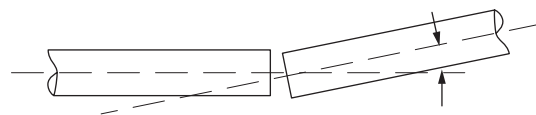

Fig. 29 Angle offset

9. Keep the angle and centre offset deviations as small as possible. If necessary, re-align the shaft.
10. Screw the motor to the base frame or foundation.
11. For details regarding the distance between the coupling flanges, refer to the coupling installation instructions, see "*Coupling subvendor documentation*" attached to this document.
12. Secure the coupling flanges at the prescribed distance on the shaft.
13. Secure the coupling belts. Tighten the screws cross-wise. Observe the prescribed tightening torques in the coupling installation instructions.
14. Mount the coupling guard.

## 10 Appendix 1

### 10.1 Technical data

#### 10.1.1 Tightening torques for screws and nuts

Material: Steel, strength class 8.8

Thread	M6	M8	M10	M12	M16	M20
Tightening torque [Nm]	11	27	54	93	230	464

Material: Stainless steel, strength class 70

Thread	M6	M8	M10	M12	M16	M20
Tightening torque [Nm]	7.4	17.5	36	62	150	303

Material: Stainless steel, strength class 80

Thread	M6	M8	M10	M12	M16	M20
Tightening torque [Nm]	10	24	49	80	203	393

#### 10.1.2 Noise emission

Pump size	Sound level dB(A)
FM222	73
FM232	74
FM242	75
FM252	78
FM322	79
FM332	80
FM342	81
FM422	78
FM432	83
FM 442	87
FMS322	82
FMS332	83
FMS342	84
FMG322	82
FMG332	83
FMG342	84

Table 9 Noise emission

The specified values apply to a 50 Hz mains connection and pump operation at maximum efficiency level. The sound pressure might deviate significantly, depending on the working point. For details, see "Pump characteristic" in the enclosed documentation.

### 10.2 Maintenance intervals<sup>1</sup>

Model	Interval	Maintenance task	Chapter
All models with sealing/ quenching liquid option	Daily	Check sealing or quenching liquid.	See Chapter 9.3 "Checking sealing and quenching liquids (optional)", page 15
L3V, L4V	Daily	Check oil level.	See Chapter 9.5 "Lubricating shaft seals", page 15
KF 2	5000 h	Lubricate shaft bearing.	See Chapter 9.5 "Lubricating shaft seals", page 15
L3V	5000 h	Change oil.	See Chapter 9.5.1 "Models L3V, L4V:", page 15
L4V	5000 h	Change oil.	See Chapter 9.5.1 "Models L3V, L4V:", page 15
All	As required	Replace shaft seal.	See Chapter 9.7 "Replace shaft seal.", page 17
All	As required	Change motor.	See Chapter 9.6 "Changing motor", page 16
All	According to manufacturer specifications	Lubricate motor bearing	See Chapter 9.4 "Lubricating motor bearing", page 15

Table 10 Maintenance intervals

<sup>1</sup>For maintenance intervals of the motor, see motor operating manual.

### 10.3 Troubleshooting

Problem	Possible cause	Remedy
<b>Pump not conveying or irregular flow rate</b>	Suction line closed / clogged	Open / clean suction line
	Suction filter dirty	Clean suction filter
	Pressure side shut-off valve closed	Open pressure line
	Pump not completely filled with liquid	Install pipeline system so that the pump casing is filled with liquid, even when at standstill
	Pump with geodetic suction height <sup>1</sup> ; liquid level drops during standstill	Install foot valve in suction line
	Suction line leaking (sucking in air)	Seal suction line
	Foot valve blocked / dirty	Clean / repair foot valve
	Suction height too great	Position pump lower Reduce suction height
	Air lock in suction line	Always lay suction lines rising to the pump
	Too much air or gas in conveying medium	Install vent valve
	Air entering through shaft seal	Check shaft seal installation Replace elastomers
	Cavitation at impeller inlet, excessive resistance in suction line, suction height too great NPSH value of unit not adjusted to pump	Optimise suction line, increase suction head, reduce medium temperature, Consult <i>Fristam</i>
	<b>Flow rate too high</b>	Pressure side valve opened too far
Diameter of pressure line too large		Reduce pipe nominal width, insert orifice plate
Impeller diameter too large		Reduce outer diameter of impeller Reduce speed with frequency inverter Consult <i>Fristam</i>
<b>Flow rate too low, conveying height too low</b>	Pump too small	Consult <i>Fristam</i>
	Impeller diameter is too small	Consult <i>Fristam</i> Replace impeller
	Incorrect motor rotation direction	Exchange connections in motor terminal box
	Rotation speed too low (incorrect voltage)	Correct power supply according to motor type plate
	Nominal diameters of pipelines too small	Install pipes with larger diameter
	Pipeline resistance in suction and/or pressure line too high	Optimise pipeline system, reduce number of bends and valves Consult <i>Fristam</i>
	Pipes clogged	Clean pipes
	Foreign objects/deposits in impeller	Remove and clean impeller
	Impeller incorrectly installed	Check impeller clearance and re-adjust
	Density of medium too high Viscosity of medium too high	Consult <i>Fristam</i>
<b>Metallic noise</b>	Foreign object in pump interior	Dismantle pump, examine and repair
	Impeller obstructed/chaffing	Readjust impeller clearance, tighten impeller nut with torque wrench
	Pump/shaft seal running dry	Add medium, open suction valve

Table 11 Troubleshooting

Problem	Possible cause	Remedy
<b>Flow noises</b>	Pump operated outside specified load range (overload)	Adjust working point to specifications
	Flow loss in suction line too high	Increase nominal width, reduce pipeline lengths, prevent gas emission
	Cavitation	Check conditions for NPSH evaluation, Consult <i>Fristam</i>
<b>Vibration</b>	Excessive suction and pressure line loads on pump	Pipes must be supported so that they do not place a load on the pump; install vibration dampers if necessary, avoid pressure surges at the pump
<b>Excessive heating of shaft bearing</b>	Damage to bearing	Replace bearing
<b>Current consumption of motor too high</b>	Flow rate too high	Close the valve in the pressure line reduce speed with frequency inverter
	Impeller diameter too large	Reduce outer diameter of impeller, Consult <i>Fristam</i>
	Viscosity and/or density of medium too high	Consult <i>Fristam</i>
	Serious damage to shaft bearing, shaft deformed	Dismantle pump, and have it examined and repaired by <i>Fristam</i>
<b>Leakage at shaft seal</b>	Impeller nut loose	Dismantle impeller, inspect shaft shoulder Check shaft seal, tighten impeller nut with prescribed tightening torque, replace parts as necessary
	Mechanical damage / wear to shaft seal or rotary shaft seal	Replace shaft seal, including elastomers, change seal material Consult <i>Fristam</i>
	Shaft seal running dry, suction height too great, medium temperature too high	Increase pump inlet pressure, reduce suction height, install double shaft seal, Consult <i>Fristam</i>
	Sealing water pressure too high	Adjust with restrictor valve
	Sealing water pressure too low	Replace radial shaft seal
	Water tube blocked, (causing damage to radial shaft seal) Sealing water dirty	Clean water tube Readjust water inlet and outlet rate, use water of drinking water quality at max. 70°C
	Medium temperature too high	Consult <i>Fristam</i> Convert to double shaft seal

Table 11 Troubleshooting

<sup>1</sup>The geodetic suction height is the vertical distance between the surface of the suction side liquid level and the centre of the impeller.



## 10.4 Numbers in sectional drawings

The part numbers in this list refer to the enclosed *sectional drawings*. The part numbers conform to DIN 24250.

Part no.	Designation
101	Pump casing
108	Stage casing
160	Cover
13-1	Back casing panel
13-2	Casing insert
130	Casing part
132	Spacer
135	Wearing bush
154	Intermediate wall
156	Outlet side
18-1	Spherical cap bearing
18-2	Vibration absorber
182	Base
21-1	Synchronizing shaft
213	Drive shaft
23-1	Rotor
26-1	Bracket for mechanical seal chamber
230	Impeller
32-1	Angular ball bearing
32-2	Cylindrical roller bearing
32-3	Grooved ball bearing
32-4	Tapered roller bearing
321	Radial ball bearing
322	Radial roller bearing
325	Needle bearing
330	Bearing holder
331	Bearing block
341	Drive lantern
344	Bearing holder lantern
350	Bearing housing
360	Bearing cover
40-4	Half-length taper grooved pin
400	Flat seal
410	Profile seal
411	Sealing ring
412	O-ring
421	Radial gasket
422	Felt ring
423	Labyrinth ring
433	Mechanical seal
45-1	Support ring
451	Stuffing box housing
454	Gland seal ring
47-1	Spring with washer
47-2	Mechanical seal chamber
47-3	Wedge seal
47-5	Ring nut
471	Sealing cover
472	Rotating seal ring
474	Thrust collar
475	Stationary seal ring
476	Counter ring holder
477	Spring for mechanical seal

Part no.	Designation
478	Spring, right
479	Spring, left
481	Bellows
482	Bellows support
484	Spring washer
485	Seal driver
500	Ring
50-1	Spring washer
50-2	V-ring
50-3.60	Adjusting ring
504	Spacer ring
520	Sleeve
523	Shaft sleeve
524	Shaft protective sleeve
525	Spacer sleeve
54-1	High-pressure cover bushing
54-2	Bushing
54-3	Stationary bushing
540	Bushing
543	Spacer bushing
55-1	Serrated washer
550	Washer
551	Spacer washer
554	Washer
561	Grooved pin
56-1	Roll pin
56-2	Grooved drive stud
560	Pin
562	Cylindrical pin
59-2	Dished type lock washer
59-3	Shrink ring
59-4	Lantern
59-5	Membrane
642	Oil level sight glass
680	Enclosure
68-1	Sheet metal strip
68-2	Foam strip
68-3	Holder for enclosure
68-4	Orifice plate
68-5	CF guard plate
681	Coupling guard
701	Bypass line
710	Pipe
71-1	Connection pipe
715	Hose pipe
722	Flange adapter
723	Flange
724	Blind flange
733	Pipe clamp
751	Valve housing
755	Valve spindle
756	Valve spring
759	Valve plate

Part no.	Designation
800	Motor
801	Flange motor
87-1	Gearbox
87-2	Gearbox cover
87-3	Gearbox cap
87-4	Gear foot
839	Contact
872	Gearwheel
89-1	Filler piece
89-2	Support for adjustable leg
89-3	Motor base
89-4	Handle
89-5	Protective cap
89-6	Wheel
89-8	Flat steel
89-9	Motor carrier
89-10	Motor carrier
89-11	Spherical cap base support
892	Foot plate
894	Bracket
897	Guide piece
90-1	Stud bolt
90-3	Taper pin
90-4	Half-length taper grooved pin
90-5	Eye bolt
900	Screw
901	Hexagon head screw
902	Stud
903	Screw plug
904	Threaded pin
906	Impeller bolt
909	Adjusting screw
91-1	Slotted cheese head screw
913	Vent screw
914	Hexagon socket screw
92-1	Long star handle nut
92-2	Short star handle nut
92-3	Cap nut
92-4	Rotor nut
92-5	Forcing screw
92-6	Rotor fixture
92-7	Nut with collar
920	Hexagon nut
921	Shaft nut
922	Impeller nut
923	Bearing nut
93-1	Snap ring
930	Retainer
931	Retaining washer
932	Snap ring
940	Key
941	Disk spring
950	Spring

## 10.5 EC Declaration of Conformity

The manufacturer: FRISTAM Pumpen KG (GmbH&Co.)  
Kurt-A.-Körber-Chaussee 55  
21033 Hamburg, Germany

declares that the following product (pump with motor):

- centrifugal pump types FP, FPE, FP...V, FPH, FPEH, FPH...V, FSPE, FSP...V, FM, FZ, FC, CF, CFE, FPM and FSM
- Positive displacement pump types: FK, FKL, FL, FL2, and FL3
- Powder mixer type: PM
- (for serial number, see cover page of operating manual)

conforms to all relevant requirements of the **EU Machinery Directive (2006/42/EC)**.

The machine also conforms to the relevant requirements laid down in the **Low Voltage Directive (2014/35/EU)** and the **EMC Directive (2014/30/EU)** No. 1935/2004 and FDA.

The above product conforms to the following standards:

- DIN EN 809:2012-10: Pumps and pump units for liquids - Common safety requirements
- DIN EN ISO 12100:2011-03: "Safety of machinery - General principles for design, risk assessment and risk reduction"

Documentation officer: Julia Friedsch

Telephone: +49(0)40 72556-107

Address: see manufacturer address

Hamburg, 30 October 2020



Julia Friedsch / Head of Quality Management



---

Fristam Pumpen KG (GmbH & Co.)  
Kurt-A.-Körber-Chaussee 55  
21033 Hamburg  
GERMANY

Telephone: +49 (0) 40 / 7 25 56 -0

Fax: +49 (0) 40 / 7 25 56 -166

Email: [info@fristam.de](mailto:info@fristam.de)