

Original Instructions
Assembly Instructions

Centrifugal Pump FP Series

Pump Type:

Pump No.:



Copyright



© Copyright 2012 Fristam Pumpen KG (GmbH & Co.)

All rights reserved. The contents, including graphic images and layout of this operating instructions manual are subject to copyright protection and to other laws for the protection of intellectual property. The publication and modification of the contents are not authorised. Moreover, you may not copy, publish and alter the contents therein for commercial purposes, or transmit the information to a third party.

The German version is the original version of the operating instructions manual. Other languages are translations of the original operating manual.

Table of Contents

1	Introduction	5	6.6	Connection of Sealing or Quenching Liquid (Optional)	13
1.1	Foreword.....	5	6.7	Cleaning.....	13
1.2	Manufacturer	5	7	Operation	13
1.3	Scope of Supply	5	7.1	Safety Instructions	13
1.4	Pump Without Motor (Optional)	5	7.2	Commencement of Operation	13
1.5	Scope of Documentation	5	7.3	Monitoring of Operation	14
1.6	Display Conventions.....	5	7.4	Stopping of Operation	14
2	Safety.....	6	7.5	Pump Decommissioning	14
2.1	Basic Safety Instructions.....	6	7.6	Cleaning in Place	14
2.2	Intended Use	6	8	Faults	14
2.3	Improper Use.....	6	8.1	Safety Instructions	15
2.4	Warning and Instruction Labels.....	6	9	Maintenance	15
2.5	Noise Emissions	6	9.1	Safety Instructions	15
2.6	Disposal	7	9.2	Replacement Parts.....	15
3	Design and Function	7	9.3	Inspection of Sealing and Quenching Liquid (Optional)	15
3.1	Principles of Design.....	7	9.4	Lubrication of Motor Bearings.....	15
3.2	Models	8	9.5	Lubrication of Shaft Bearing	15
3.3	Pump Key	9	9.6	Motor Replacement	17
3.4	Versions	9	9.7	Shaft Seal Replacement	18
4	Transportation.....	9	9.8	Pump Head Removal	18
4.1	Transportation	9	9.9	Checking of the Clearances.....	18
5	Storage	10	9.10	Pump Head Attachment.....	20
5.1	Safety Instructions	10	9.11	Models FPE and FP...V: Mounting and Alignment of the Pump Shaft.....	27
5.2	Storage Conditions.....	10	9.12	Model L: Coupling Replacement	27
5.3	Long-Term Storage	11	10	Appendix 1	28
5.4	Recommissioning	11	10.1	Specifications.....	28
6	Installation	11	10.2	Maintenance Intervals ¹	28
6.1	Safety Instructions	11	10.3	Troubleshooting Table.....	29
6.2	Installation Location	11	10.4	Number Key	31
6.3	Reduction of Noise and Vibration.....	11	10.5	EC Declaration of Conformity	33
6.4	Pump Fixation	11	10.6	EG Declaration of Incorporation.....	33
6.5	Electrical Connection.....	12			

11	Appendix 2 – Assembly Instructions (Optional)	34
11.1	Safety Instructions	34
11.2	Scope	34
11.3	Rating Plate	34
11.4	Moving Without Motor	34
11.5	Installation Location	35
11.6	Pump Installation	35

1 Introduction

1.1 Foreword

This operator's manual describes all FP centrifugal pump sizes, models, and versions.

Information on the model, size, and version of your pump can be found on the rating plate on your pump and in the "Order-Related Documents" in the attached documents.

1.2 Manufacturer

FRISTAM Pumpen KG (GmbH & Co.)

Kurt-A.-Körber-Chaussee 55

21033 Hamburg

GERMANY

Tel.: +49-40-72556-0

Fax: +49-40-72556-166

E-mail: info@fristam.de

1.3 Scope of Supply

The package includes the following items:

- Pump with motor = pump unit
 - optional: without motor
- Covers for pipe fittings
- Optional: assembly kit
- *Fristam* accessories (if applicable)
- Documentation
- ▶ Check the shipment for completeness and damage. Immediately notify *Fristam* of any missing items or damage.

1.4 Pump Without Motor (Optional)

The pump can optionally be supplied without a motor. In this case, continue reading up to and including *Chapter 3, "Design and Function," page 7*, and then skip to *Chapter 11, "Appendix 2 – Assembly Instructions (Optional)," page 34*.

1.5 Scope of Documentation

The documentation includes the following items:

- **This operator's manual**
 - Appendix 1 with maintenance, lubrication, and tightening torque tables
 - Appendix 2 with assembly instructions
- **Attached documents:**
 - Order-Related Documents
 - Supplier Documentation (motor, coupling, etc.)

- Documentation on *Fristam* accessories (if applicable)
- Certificates (materials certificates, etc.), if applicable
- Declaration of Conformity or Declaration of Incorporation

1.6 Display Conventions

List items are preceded by dashes:

- Part 1
- Part 2

Handling instructions that must be performed in a specified order are numbered:

1. Turn device on.
2. Turn device off.

Handling instructions that do not need to be performed in a specified order are preceded by triangular bullets:

- ▶ Action
- ▶ Action

1.6.1 Safety Instructions

⚠ DANGER

A safety instruction with the signal word "Danger" indicates personal hazards causing death or serious injury.

⚠ WARNING

A safety instruction with the signal word "Warning" indicates personal hazards that may lead to death or serious injury.

⚠ CAUTION

A safety instruction with the signal word "Caution" indicates personal hazards that may lead to mild to moderate injuries.

NOTICE

A safety instruction with the signal word "Note" warns of the possibility of material damage.

2 Safety

2.1 Basic Safety Instructions

- ▶ Please read this operator's manual completely before using the pump and keep it available at the pump installation location.
- ▶ Heed the applicable national regulations of the owner's country and the company's work and safety regulations.
- ▶ All work described here may only be performed by qualified experts with caution.
- ▶ Danger of contamination: Heed legal and operational safety regulations when pumping dangerous media.
- ▶ While the pump is running, do not remove safety disconnectors.

2.2 Intended Use

The standard FP centrifugal pump versions are designed for use in the food industry, the pharmaceutical and biotechnology industry, and CIP process technology.

They can be used to pump liquids with dynamic viscosities of up to 1200 mPa s and media temperatures of up to 150°C. The medium can contain a slight amount of air or gas, be homogeneous, or contain a small amount of additives.

Each pump is designed according to customer requirements. The seal materials have been selected for the respective medium. The pump may only be used to pump the medium it was designed for (see "Order-Related Documents" in the attached documents).

2.3 Improper Use

The standard FP centrifugal pump versions may not be used in explosive atmospheres. Special explosion-proof versions are available for this.

Pumping of media other than those specified can destroy the pump.

Standard pump units from *Fristam* are described in this operator's manual. If nonstandard items or extras are installed, the operator assumes the responsibility for operation.

Modifications and changes to the pump are only permissible with the explicit consent of *Fristam*.

2.4 Warning and Instruction Labels

- ▶ Do not alter or remove the labels on the pump.
- ▶ Immediately replace damaged or lost labels with ones that are true to the originals.

2.4.1 Direction of Rotation



Fig. 1 "Impeller Direction of Rotation" label

This label shows the direction of rotation of the impeller. It is located at the front on the pump cover.

2.4.2 Hot Surface



Fig. 2 Safety label: "Hot Surface"

This label indicates that parts can become hot during operation or, if applicable, that hot media is being pumped. Only touch the pump if you are wearing suitable gloves.

2.4.3 No Dry Running

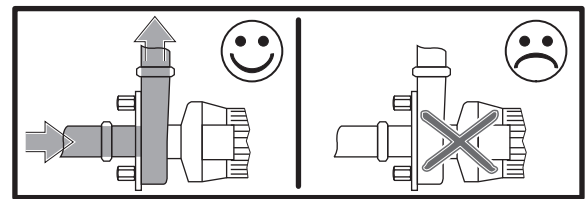

Fig. 3 Safety label: "No Dry Running"

This label indicates that the pump cannot be run dry. There must always be medium in the suction line and the pump when the pump is started. Otherwise, the pump will be damaged.

2.4.4 Rating Plate

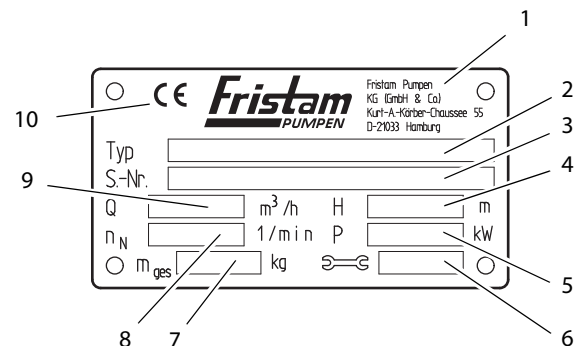

Fig. 4 Pump unit rating plate

- 1 Manufacturer
- 2 Type: pump series, pump size, model, version
- 3 SN: serial number of the pump
- 4 H: discharge head [m]
- 5 P: motor output [kW]
- 6 Year of manufacture
- 7 m_{ttl}: mass (total) [kg]
- 8 n_R: rated speed [1/min]
- 9 Q: flow rate [m³/h]
- 10 CE mark

2.5 Noise Emissions

- ▶ The local noise exposure regulations must be complied with. For noise emission values for the pumps, please see Chapter 10.1, "Specifications," page 28.

⚠ CAUTION

Noise Generated by Running Pump

Hearing damage.

- ▶ Wear ear protectors when using pumps with specified sound pressure levels of greater than 80 dBA.

2.6 Disposal

2.6.1 Disposal of Transportation Package

- ▶ Recycle the transportation package.

2.6.2 Models KF and L 1: Disposal of Grease

- ▶ Dispose of grease and objects saturated with grease in an environmentally friendly manner in accordance with applicable regulations.

2.6.3 Models L 2, L 3/L3V, L 4V: Disposal of Lubricating Oil

- ▶ Dispose of oil and objects saturated with oil in an environmentally friendly manner in accordance with applicable regulations.

2.6.4 Disposal of Pump

1. Carefully clean the pump. Dispose of residues in an environmentally friendly manner in accordance with applicable regulations.
2. Dismantle the pump into its constituent parts.
3. Dispose of the pump parts in an environmentally friendly manner in accordance with applicable regulations.

2.6.5 Disposal of Electrical and Electronic Scrap

- ▶ Dispose of electrical and electronic scrap in accordance with applicable directives.

3 Design and Function

3.1 Principles of Design

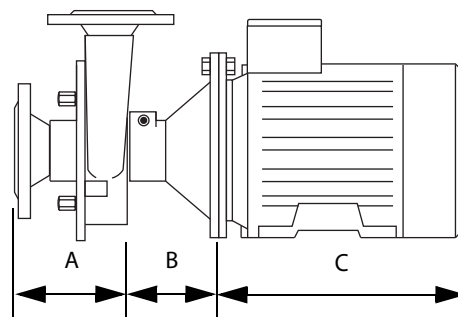

Fig. 5 Principles of design of pumps illustrated using the FPE model

A	Pump head
B	Lantern
C	Electric motor

3.1.1 Pump Head (A)

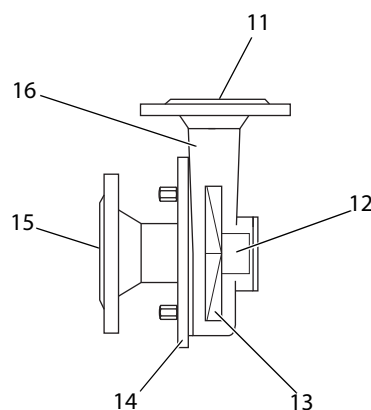

Fig. 6 Pump head

11	Discharge line connection
12	Shaft seal
13	Impeller
14	Pump cover
15	Suction line connection
16	Pump casing

Shaft Seal (12)

Two seal types are available for use:

- Single shaft seal
- Double shaft seal

With the double shaft seal, there are two additional connections for the sealing liquid on the pump casing. These connections are not shown in the following figures.

Impeller (13)

Open impellers are standardly used in the FP pump series.

Pump Cover (14)

The connection for the suction line is located on the pump cover.

Pump Casing (16)

The connection for the discharge line is located on the pump casing. The impeller and the shaft seal are built into the pump casing.

3.1.2 Lantern (B) and Electric Motor (C)

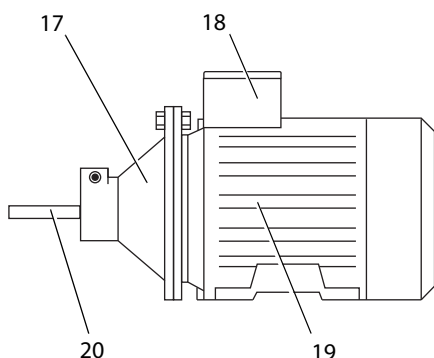

Fig. 7 Lantern and electric motor

17	Lantern
18	Electrical connection
19	Electric motor
20	Pump shaft

Lantern (17)

The lantern is present in all models except the special motor.

The lantern connects the pump casing to the motor. Two different versions are possible, depending on pump size:

- The pump casing is screwed to the lantern via a flange connection.
- The pump casing is inserted into the lantern and mounted with a clamp.

Models with lanterns:

- FPE and FP...V
- KF
An additional bearing for the pump shaft is located inside the lantern with base.
- L
An additional bearing for the pump shaft is located inside the lantern with base. The pump shaft is connected to the motor via a coupling.

Electric Motor (19)

The following motor types can be mounted:

- IEC standard motor with drive side fixed bearing (A side), feather key and shaft pin of the following types:
 - IM B3: model with base
 - IM B5: model with flange
 - IM B3/5: model with flange and base

With the IEC standard motor, a *Fristam* pump shaft is clamped to the motor shaft pin.

- Special motor with *Fristam* pump shaft

With the special motor, the *Fristam* pump shaft is already integrated and connected permanently to the motor.

3.2 Models

The model is indicated on the rating plate. See *Chapter 2.4.4, "Rating Plate," page 6.*

The following are shown as examples:

- Lantern clamp-mounted
- Without enclosure
See *Chapter 3.4, "Versions," page 9.*

3.2.1 Model FP

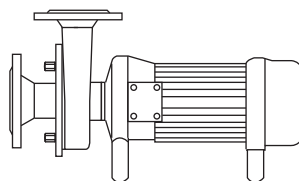

Fig. 8 Model FP

Motor: Special motor

Design: Without lantern

3.2.2 Model FPE or FP...V

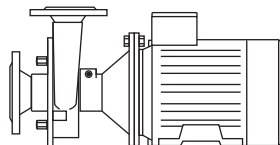

Fig. 9 Model FPE or FP...V

Motor: IEC standard motor, model B3/B5

Design: With lantern

3.2.3 Model KF

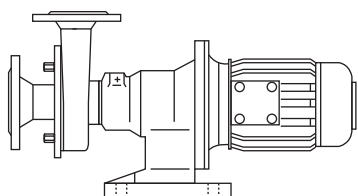

Fig. 10 Model KF

Motor: IEC standard motor, model B5

Design: Compact bearing support with base

3.2.4 Model L

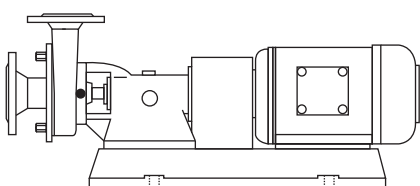

Fig. 11 Model L

Motor: IEC standard motor, model B3

Design: Bearing block with coupling, coupling protection, base frame

3.3 Pump Key

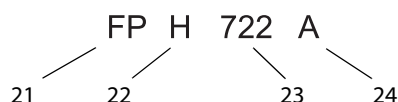

Fig. 12 Type designation example

21	Pump type
22	Supplementary character 1
23	Pump size
24	Supplementary character 2

(21) Pump Type

- FP Special motor with extended motor shaft
- FPE Attached pump shaft
- FP...V Extended insert shaft as pump shaft

(22) Supplementary Character 1

- S Open impeller with large clearance to casing
- R Semiopen impeller with large clearance to cover
- H High-pressure pump
- X Impeller for high pressures
- Z Casing with circulation line

(24) Supplementary Character 2

A, B ,C ,D Versions; see Chapter 3.4, "Versions," page 9:

- KF Compact bearing support with base
- L1, L2, L3 Bearing block with coupling
- V Stainless steel lantern, double shaft seal, ø75mm at lantern neck
- H Pump casing with heating jacket
- h Pump cover with heating jacket

3.4 Versions

Version	Enclosure	Spherical Cap Legs	Motor Foot
A	With	With	Without
B	Without	Without	With
C	Without	With	Without
D	With	Without	With

Table 1 Versions

Note: If the (optional) pump without motor is supplied, please first read Chapter 11, "Appendix 2 – Assembly Instructions (Optional)" on page 34.

4 Transportation

4.1 Transportation

Transportation may only be performed by trained personnel.

The pump can be moved using an industrial truck or a crane.

Always move the pump in the installation condition.

4.1.1 Safety Instructions

- ▶ Danger of injury from falling or unsecured parts.
 - Only use suitable means of conveyance and hoists. Information on pump weight can be found on the pump's rating plate as well as in the "Order-Related Documents" in the attached documents.
 - Before moving the pump secure it to prevent it from tipping over. Secure the pump to the pallet with tie-down straps, or screw the pump to the pallet.
 - Do not leave the pump in a raised position for longer than necessary.
- ▶ Damage to pump by contamination, impact, or moisture.
 - Remove the protective film just prior to installation.
 - Remove the pipe fitting covers just prior to connection to the pipes.

4.1.2 Moving With Industrial Trucks

Preparation

- ▶ Ensure that the pump is adequately secured to the pallet.

Procedure

1. Pick up the pallet with the forks on the industrial truck.
2. Carefully move the pallet to the designated location and set down.

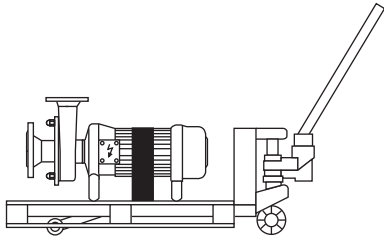

Fig. 13 Moving with industrial truck

4.1.3 Moving With Crane

⚠ WARNING

Falling Parts

Death from crushing, pinching of extremities, material damage.

- ▶ Do not lift the pump at the eyebolts on the motor and pump casing to move because these eyebolts are not designed for the total weight.
- ▶ Only use hoists that are designed for the total weight of the pump.
- ▶ Ensure that the area below the pump is clear of people.

⚠ WARNING

Swinging Parts

Crushing and serious injuries.

- ▶ Start and stop the crane with pump smoothly.
- ▶ Ensure that the danger zone of the pump is clear of people.

Auxiliary Equipment

Hoists: round slings tested in accordance with DIN EN 1492-1 and 1492-2

Preparation

- ▶ Remove load-securing devices.

Procedure

1. Wrap the round sling twice around the back end of the motor. Do not lay over the fan shroud (see Fig. 14 Moving with crane).
2. Lay the other end of the round sling between the lantern and the pump casing. Do not lay the round sling over any sharp edges or corners.

3. Guide both loops to the crane hook and rotate by 180° to ensure that the belt will not slip on the hook.

4. For double shaft seal:

Note: Round sling compresses sealing water tubes. Material damage to double shaft seal.

- ▶ Do not lay the round sling on the sealing water tubes.

5. Position the center of gravity to ensure that the pump is lifted horizontally.

6. Lift the pump.

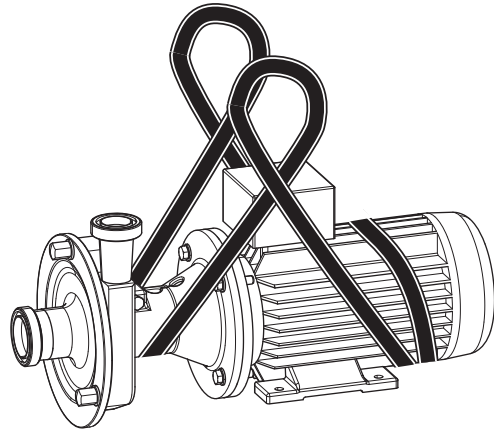

Fig. 14 Moving with crane

5 Storage

5.1 Safety Instructions

- ▶ Corrosion: Condensation can build up under a tarp and destroy the pump.
 - Ensure adequate ventilation.

5.2 Storage Conditions

- ▶ Store the pump as follows:
 - Dry, in low humidity
 - Protected against frost and heat, optimally at a temperature of 20°C to 25°C
 - Ventilated
 - Dust-free

5.3 Long-Term Storage

For a storage time of longer than six months, heed the following:

- ▶ The shaft seals must be specially treated before long-term storage:

- **For single shaft seal**

The impeller nut must be loosened so that the seal can relax and the elastomers do not stick together.

- **For double shaft seal**

Remove the complete shaft seal and store separately to prevent the elastomers from sticking together.

Information on the shaft seal can be found in the "Order-Related Documents".

- ▶ All movable pump parts must be rotated every three months.

5.3.1 Storage of Elastomers

Storage Conditions

- Storage temperature between +5°C and +20°C
- Relative air humidity below 70%
- No direct sunlight
- Deformation-free storage

5.4 Recommissioning

- ▶ After long-term storage and before commissioning, check seals, bearings, and lubrication.

6 Installation

6.1 Safety Instructions

- ▶ Danger of injury from falling parts.
 - Wear safety shoes.
 - Check load capacity and attachment of hoists.
- ▶ Danger of injury from unstable assembly.
 - Tighten screws to the specified tightening torque (see *Chapter 10.1.1, "Tightening Torques for Screws and Nuts," page 28*).
 - Use a torque wrench or an impact driver with adjustable torque.
- ▶ Material damage from swinging during adjustment of spherical cap feet.
 - Use spherical cap base plates.

6.2 Installation Location

For standard pumps, the installation location must meet the following requirements:

- Nonexplosive atmosphere
- Dust-free environment
- Ambient temperature: –20°C to +40°C
- Moisture and salt contents in ambient air: The values are given in the motor supplier documentation. It can be found in the attached documents.
- Foundation sized adequately for the pump weight
- Horizontal and level installation surface, adequate installation surface strength for pump mass
- Adequate clearance for maintenance work
- Adequate air supply for motor cooling

6.3 Reduction of Noise and Vibration

6.3.1 Primary Measures

- ▶ Operate the pump in the optimum working range.
 - Do not starve the pump. Avoid throttling too much. Only operate with a low flow rate if necessary for regulation purposes.
 - Do not operate with very high flow rates. Optionally install a flow controller in the discharge line.
 - Operate the pump without cavitation (see *Chapter 6.4.1, "Installation of Pipes," page 12*).
- ▶ Decouple the suction and discharge lines from vibrations.
 - Support lines.
 - Align lines.
 - Install vibration isolators.

6.3.2 Secondary Measures

- ▶ Take structural measures such as the following:
 - Acoustic paneling
 - Enclosure in housing

6.4 Pump Fixation

Models FP/FPE/FP..V

- ▶ Versions A and C:
Set up the pump on the spherical cap bearings and align.
- ▶ Versions B and D:
Screw the pump on the motor foot to the foundation.

Model KF

- ▶ Versions A and C:
Set up the pump on the spherical cap bearings and align.

- ▶ Versions B and D:
Screw the pump on the compact bearing support with base to the foundation.

Model L

- ▶ Versions A and C:
Set up the pump on the spherical cap bearings and align.
- ▶ Versions B and D:
Screw the pump on the base frame to the foundation.

Carriage (Optional)

1. Set up the pump at the installation location. Lock the locks on the rollers (if present) or secure the carriage with chocks.
2. Ground the carriage to dissipate electrostatic charge.
3. Position hose line to ensure that it cannot be damaged.

6.4.1 Installation of Pipes

- ▶ Lay and connect pipes as follows:
 - Keep the pipe resistance as low as possible: Avoid unnecessary installation of valves, elbows, and abrupt pipe transitions.

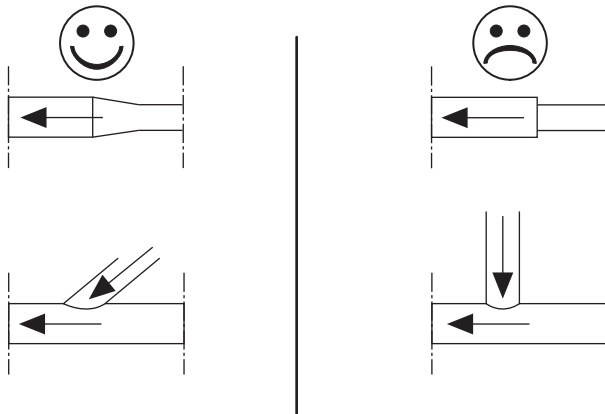

Fig. 15 Pipe transitions

- Design pipe cross section so that no unnecessary pressure losses or cavitation occurs in the suction area and so that the condition $NPSH_a > NPSH_r$ is fulfilled.
Verify this in the project planning stage.
- Install the suction lines in horizontal position or at a constant dropping angle towards the pump unit. Rule out the possibility of air pockets and dips in the pipes.

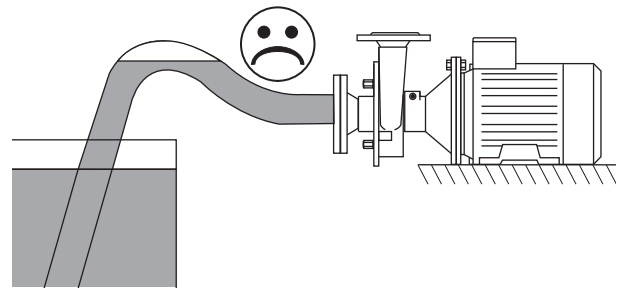

Fig. 16 Air pocket

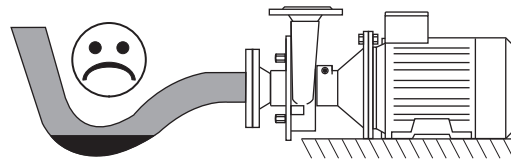

Fig. 17 Dip in pipe

- Pipe bends upstream of suction connection: Heed minimum clearance and minimum bend radius:

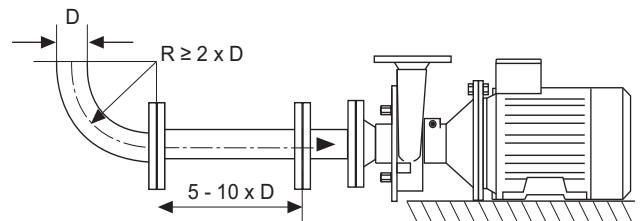

Fig. 18 Laying of the suction line

- Connect the pipes to the pump so that they are free of tension and compression to ensure that no stresses are applied to the pump.
- Secure pipes to ceilings, walls, or floor using pipe clamps.
- Align pipes flush with pump connections using a bracket.

6.5 Electrical Connection

Electrical connection may only be performed by a qualified electrician.

1. Heed the connection values on the motor's rating plate. The specified voltage must not be exceeded.
2. Connect the motor according to the circuit diagram in the terminal box of the motor.
3. Protect cable feedthroughs against penetration by moisture.
4. Turn on the motor for 2 to 3 seconds. Compare the direction of rotation of the motor fan wheel against the direction indicated by the arrow on the pump head.
5. Reverse the polarity if necessary.

6.6 Connection of Sealing or Quenching Liquid (Optional)

In versions with double shaft seal, the seal chamber must be flushed with a sealing or quenching liquid.

- ▶ Use a suitable medium, e.g., water, as a sealing or quenching liquid.

6.6.1 Installing the pipelines

1. Install and seal the supplied flushing tubes.
2. As a standard, the feed line should be fitted at the **bottom** of the shaft seal.
3. As a standard, the return line should be fitted at the **top** of the shaft seal.

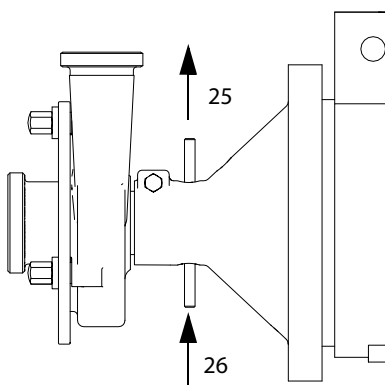

Fig. 19 Installing the pipelines

25	Return line
26	Inlet

4. Install the following valves into the pipelines:
 - Install the sight glass in the return line.

6.7 Cleaning

Only use cleaning agents that comply with the hygiene guidelines for the respective pumping medium.

1. Before sealing the pump ensure that there are no foreign objects inside the pump or pipes.
2. Seal the pump.
3. Connect the pipes.
4. Thoroughly clean the pump and the pipe system before initial use.

7 Operation

7.1 Safety Instructions

- ▶ **Danger of burning:** Pumping of hot media can cause the pump to become very hot. Check the temperature before touching the pump.
- ▶ **Noise emissions:** The A-weighted sound pressure level of the pumps can be greater than 80 dBA. Always wear ear protectors in the vicinity of the running pump.
- ▶ **Danger of bursting:** If the allowable pressure and temperature ranges are exceeded, the pump may burst or become leaky. The pressure and temperature ranges for the pump must be complied with; see "Order-Related Documents" in the attached documents.
- ▶ **Danger of bursting:** Cold extinguishing agents used to extinguish a pump fire can cause the hot pump to burst. Do not cool the pump down excessively when extinguishing the fire.
- ▶ **Pump running in reverse direction despite emergency shut-off:** If the pump is shut off using the emergency shut-off function, it will run in reverse direction due to the pumping medium in the discharge line. Install a check valve in the discharge line.
- ▶ **Destruction of shaft seal when pump runs in reverse direction.** Reverse running destroys the springs in the shaft seal. Always operate the pump in the direction of rotation. See Chapter 2.4.1, "Direction of Rotation," page 6.

7.2 Commencement of Operation

NOTICE

Damage to Shaft Seals

If the pump runs without a pumping medium, the mechanical seal will be damaged.

- ▶ Ensure that the pumping medium always reaches the upper edge of the outlet side before and during operation.

NOTICE

Damage to Double Shaft Seals

If the pump runs without a sealing medium, the shaft seal will be damaged.

Ensure that during operation:

- ▶ The sealing liquid flows with the necessary pressure through the double shaft seal.

The prescribed sealing fluid pressure is specified in the "Order-related documents" in the sectional drawing of the shaft seal. The "Order-related documents" are included in this operating manual.

- Negative pressure in the seal chamber is not allowed.

If no pressure is noted in the "Sectional drawing of the shaft seal", the following applies:

- A max. pressure of 0.2 bar is allowed for seals to which sealing fluid is applied without pressure or which are flushed.
- ▶ The temperature of the sealing liquid is maintained at $T < 70\text{ °C}$.

1. Open the valve in the suction line.
2. Close the valve in the discharge line.
3. Fill the pump and the suction line up to the upper edge of the pump with pumping medium. Allow any air pockets that are present to escape.
4. Turn on the motor. The pump now pumps against the closed valve in the discharge line. This will limit the starting current.
5. Slowly open the valve in the discharge line and adjust to the working point.

7.3 Monitoring of Operation

During operation heed the following points:

- ▶ Damage to shaft seal: Regulation of the pump output via the suction-side valve can lead to damage of the pump and the shaft seals. Regulate the pump output only by means of the discharge-side valve.
- ▶ Damage to pumping medium: If during operation the valve in the discharge line is closed abruptly or for a long period of time, water hammers can occur in the pump and lead to damage to the pump and/or the pumping medium. During operation do not close the valve in the discharge line abruptly or for a long period of time.
- ▶ Damage to pump: Exceeding of the output can lead to damage of the pump and the shaft seals. Do not exceed the maximum speed of 3,600 rpm.
- ▶ Damage to motor during operation with frequency converter: If the speed is too low, the motor will overheat. Please refer to the motor supplier documentation in the attached documents.

7.4 Stopping of Operation

1. Turn off the motor.
2. Close the valve in the suction line to prevent dry running of the pump.
3. Close the valve in the discharge line.

7.5 Pump Decommissioning

1. Turn off the motor.
2. Close the valve in the suction line.
3. Close the valve in the discharge line.
4. De-energize the pump.
5. Empty the pump.
6. Clean the pump.

7. Dry the pump.
8. Protect the interior of the pump from moisture, e.g., with silica gel.
9. Seal the pipe connections with caps to prevent penetration of dirt and foreign objects.
10. Please see *Chapter 5, "Storage," page 10* for additional steps.

7.6 Cleaning in Place

7.6.1 CIP Process

The FP series pumps are suitable for the CIP (Cleaning In Place) process. The following guidelines apply to the CIP process:

Example of a Cleaning Cycle

1. Perform preliminary flush with water.
2. Perform caustic flush with lye (NaOH; see *Table 2 CIP cleaning*).
3. Perform intermediate flush with water.
4. Perform acid flush with nitric acid (HNO₃; see *Table 2 CIP cleaning*).
5. Flush with water.

Medium	Process Temperature [°C]
NaOH (approx. 1%–2%)	80–85
HNO ₃ (approx. 1%)	60–65

Table 2 CIP cleaning

The pump's differential pressure should be 2–3 bar so that adequate flow rates are reached.

If values deviate from these specifications, please contact *Fristam*.

7.6.2 SIP Process

The FP series pumps can only be used with the SIP (Sterilization In Place) process with the prior approval of *Fristam*.

Suitability depends on the selected elastomers.

The maximum process temperature is 145°C.

In ATEX operation, temperatures might deviate, see supplementary ATEX manual, "*Temperature limits*".

8 Faults

For information on faults, possible causes, and remedies, please see *Chapter 10.3, "Troubleshooting Table," page 29*.

8.1 Safety Instructions

- ▶ Danger of burning: Pumping of hot media can cause the pump to become very hot. Check the temperature before touching the pump.
- ▶ Pump running in reverse direction despite emergency shut-off: If the pump is shut off using the emergency shut-off function, it can continue to run in reverse direction due to the pumping medium in the discharge line. Install a check valve.

9 Maintenance

For information on maintenance intervals, please see Chapter 10.2, "Maintenance Intervals¹," page 28.

9.1 Safety Instructions

- ▶ Rotating parts: Danger of injury. Before removing the coupling guard and guard plate, turn off the pump motor and prevent it from being able to be turned on accidentally.
- ▶ Danger of burning: Pumping of hot media can cause the pump to become very hot. Check the temperature before touching the pump.
- ▶ Electric shock: Liquids flowing through the system result in buildup of electrostatic charge. Ground the pipes and the pump.
- ▶ Uncontrolled outflow of liquids: Before maintenance or adjustment of the pump:
 - Close the suction and discharge valves in front of and behind the pump.
 - Block off the sealing or quenching liquid line.
- ▶ Leaking liquids: Acid burns and contamination. Before opening the pump completely empty the pump casing.
- ▶ Tension cracks: Do not rapidly cool the pump. Material damage from scratching of polished surfaces. For a polished surface, use a copper socket wrench socket.

9.2 Replacement Parts

- ▶ Use of replacement parts that are not approved by *Fristam Pumpen KG* (GMBH & Co.) can lead to serious personal injury and material damage. If you have any questions regarding approved replacement parts, please contact *Fristam*.
- ▶ *Fristam* registers all shipped pumps. For ordering replacement parts from *Fristam*, you require the following information:
 - Serial number: see
 - rating plate or
 - number stamped into pump casing.

9.3 Inspection of Sealing and Quenching Liquid (Optional)

For pumps equipped for "locking system" or "quenching system," the sealing liquid head must be checked daily.

- ▶ Check the sealing liquid head and compare with the specified value.

The specified value can be found in the *Order-Related Documents* on the "Sectional Drawing" of the shaft seal. The *Order-Related Documents* are attached to this operator's manual.
- ▶ The sealing liquid is heated by hot pumping medium and by operation of the pump.

Ensure that the temperature of the sealing liquid is $T < 70\text{ }^{\circ}\text{C}$ during operation.

9.4 Lubrication of Motor Bearings

- ▶ Lubricate the motor bearings in accordance with the motor manufacturer's specifications (see "*Motor Supplier Documentation*").

9.5 Lubrication of Shaft Bearing

9.5.1 Models FP, FPE and FP...V

The models FP, FPE, and FP...V do not have additional shaft bearings, and hence no shaft bearing lubrication is necessary.

9.5.2 Models L 2, L 3/L3V and L 4V

For the models L 2, L 3/L3V, and L 4V, the oil must be changed at regular intervals.

1. Turn on the motor and let it run until the normal operating temperature is reached.
2. Turn off the motor and prevent it from being able to be turned on accidentally.
3. Place a suitable oil collection container under the oil drain plug.
4. **Caution!** Danger of burning from hot oil.
 - ▶ Wear suitable protective gloves.
 - ▶ Loosen and remove the oil drain plug.
5. Drain the oil completely and dispose of oil in accordance with local regulations.
6. Clean and remount the oil drain plug and seal.
7. Fill with new oil. We recommended using the: SAE 15W40 oil type. Alternatively, use an equivalent brand of lubricant of similar quality and viscosity. For the required amount, please see *Table 3 Oil volumes*.

Type	Oil Volume
L 2	1 liter
L 3/L3V	3 liters

Table 3 Oil volumes

Type	Oil Volume
L 4V	13 liters

Table 3 Oil volumes

9.5.3 Model L1

- ▶ Do not relubricate the deep groove ball bearing, but replace it completely.
- At constant operating conditions, the raising of power consumption, noise level or vibration indicates that wear has occurred. Replace the deep groove ball bearing consequently.

Model	Bearing Grease Amount
L1	10 g

Table 4 Bearing grease amount: model L1

Prerequisites

- Pump head has been removed.
- Motor with coupling has been removed.

Procedure

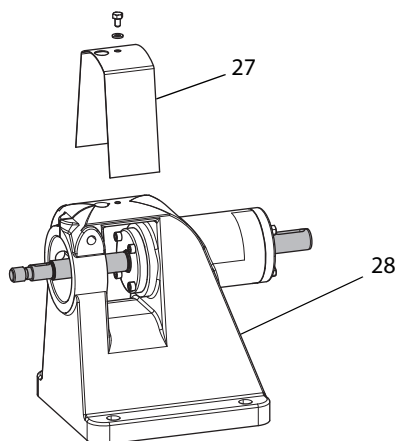

Fig. 20 Removing bearing block cover

1. Take the cover (27) off of the bearing block (28).

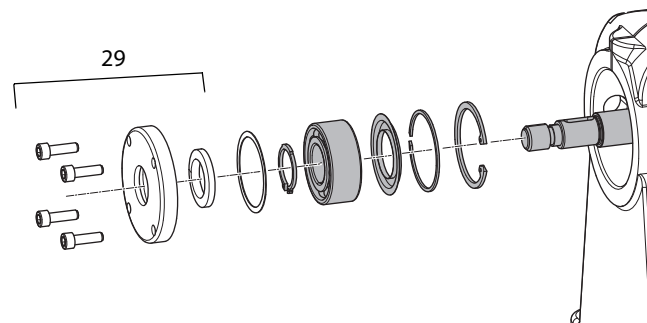

Fig. 21 Model L1, pump shaft, pump-side

2. Remove the bearing cap (29) on the pump side.

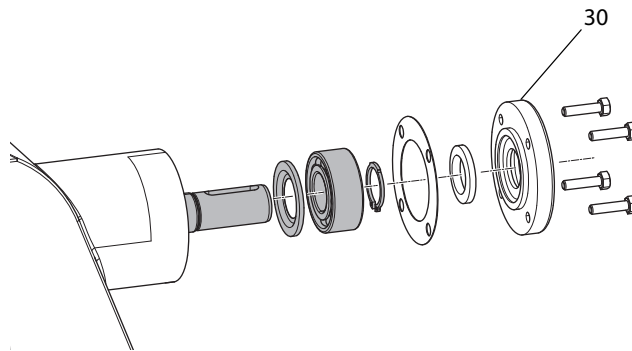

Fig. 22 Model L1, pump shaft, motor-side

3. Remove the bearing cap (30) on the motor side.
4. Force out the shaft in the direction of the pump head.
 - Note: All parts that are gray in the above two figures remain on the shaft.
5. Clean the surfaces of all parts and check for damage. Replace if necessary.
6. Relubricate the angular contact ball bearing. We recommend using: JAX Halo-Guard FG-2 bearing grease or alternatively a white NSF H1 grease. Alternatively, use an equivalent brand of lubricant of similar quality and viscosity. See Table 4 Bearing grease amount: model L1.
7. Press the pump shaft with the bearing into the bearing block.
8. Mount the bearing cap on the motor side.
9. Mount the bearing cap on the pump side.
10. Mount the cover (27).

9.5.4 Model KF

- ▶ Do not relubricate the deep groove ball bearing, but replace it completely.
- At constant operating conditions, the raising of power consumption, noise level or vibration indicates that wear has occurred. Replace the deep groove ball bearing consequently.
- ▶ Grease the cylindrical roller bearing with bearing grease.

Model	Bearing Grease Amount
KF 1	20 g
KF 2	40 g
KF 3	60 g

Table 5 Bearing grease amounts: model KF

Prerequisites

- Pump head has been removed.
- Motor has been removed.

Procedure

1. Remove the bearing cap (33).
2. Force out the pump shaft (31) with the bearing toward the motor side.

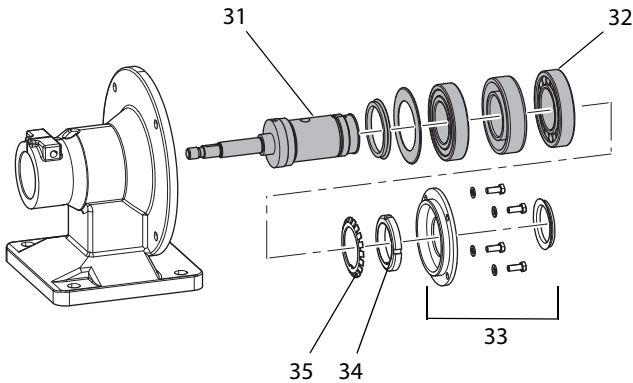

Fig. 23 Model KF, shaft bearing

3. Remove the bearing nut (**34**) and the guard plate (**35**).
4. Remove the outer race of the cylindrical roller bearing.

Note: All parts that are gray in the above figure remain on the shaft.
5. Clean the surfaces of all parts and check for damage. Replace if necessary.
6. Relubricate the cylindrical roller bearing (**31**). We recommended using: JAX Halo-Guard FG-2 bearing grease or alternatively a white NSF H1 grease. Alternatively, use an equivalent brand of lubricant of similar quality and viscosity. See *Table 5 Bearing grease amounts: model KF*.
7. Put the outer race back onto the shaft.
8. Place the guard plate and the bearing nut on the shaft, and tighten the bearing nut.
9. Press the pump shaft with the bearing back into the lantern.
10. Mount the bearing cap (**33**).

9.6 Motor Replacement

Special Motor

1. Turn off the motor and prevent it from being able to be turned on accidentally.
2. Remove the pump head (see *Chapter 9.8, "Pump Head Removal," page 18*).
3. Replace the special motor.
4. Replace the mechanical seal if necessary, and mount the pump head (see *Chapter 9.10, "Pump Head Attachment," page 20*).

IEC Standard Motor for FPE and FP...V

1. Turn off the motor and prevent it from being able to be turned on accidentally.
2. Remove the pump head (see *Chapter 9.8, "Pump Head Removal," page 18*).
3. Take the lantern off of the motor.
4. Remove the shaft.
5. Replace the motor.

6. Mount the shaft and align (see *Chapter 9.11, "Models FPE and FP...V: Mounting and Alignment of the Pump Shaft," page 27*).
7. Mount the lantern.
8. Only for flange connection: Check the clearance if necessary (see *Chapter 9.9, "Checking of the Clearances," page 18*).
9. Replace the mechanical seal, and mount the pump head (see *Chapter 9.10, "Pump Head Attachment," page 20*).

IEC Standard Motor for Model KF

1. Turn off the motor and prevent it from being able to be turned on accidentally.
2. Take the motor off of the compact bearing support with base.
3. Dispose of the motor in an environmentally friendly manner. See *Chapter 2.6.5, "Disposal of Electrical and Electronic Scrap," page 7*.
4. Insert the key of the old motor into the new motor.
5. Screw the motor to the compact bearing support with base.

IEC Standard Motor for Model L

1. Turn off the motor and prevent it from being able to be turned on accidentally.
2. Remove the coupling guard.
3. Detach the motor from the base frame or the foundation.
4. Take the coupling parts off of the motor.
5. Dispose of the motor in an environmentally friendly manner. See *Chapter 2.6.5, "Disposal of Electrical and Electronic Scrap," page 7*.
6. Mount the coupling parts onto the replacement motor (proceed as described in *Chapter 9.12, "Model L: Coupling Replacement," page 27* to replace the coupling).
7. Place the replacement motor on the base frame or the foundation.
8. Check the parallel and angular misalignment of the shafts.

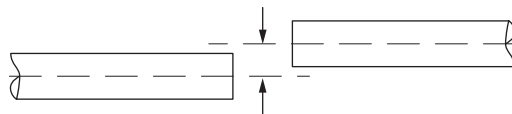

Fig. 24 Parallel misalignment

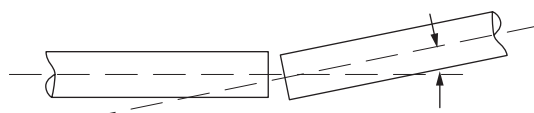

Fig. 25 Angular misalignment

9. Minimize deviations from the angular and parallel misalignment. Realign the shafts if necessary.
10. Screw the motor to the base frame or the foundation.
11. Mount the coupling guard.

9.7 Shaft Seal Replacement

The shaft seal must be replaced if:

- Pumping medium or sealing or quenching liquid flows out of the pump on the atmosphere side.
- Sealing liquid leaks into the pumping medium.

Procedure

1. Remove the pump head (see Chapter 9.8, "Pump Head Removal," page 18).
2. Replace the mechanical seal, and mount the pump head (see Chapter 9.10, "Pump Head Attachment," page 20). Perform the following tasks according to the given shaft seal:
 - ▶ Preassemble the seals on the shaft.
 - ▶ Preassemble the pump casing.
 - ▶ Mount the pump casing on the lantern.
 - ▶ Mount the mechanical seal.
 - ▶ Mount the impeller.
 - ▶ Screw on the pump cover.

9.8 Pump Head Removal

9.8.1 Preparation

1. Turn off the motor and prevent it from being able to be turned on accidentally.
2. Close the valve in the discharge line.
3. Close the valve in the suction line.
4. Completely empty the pump.

9.8.2 Procedure

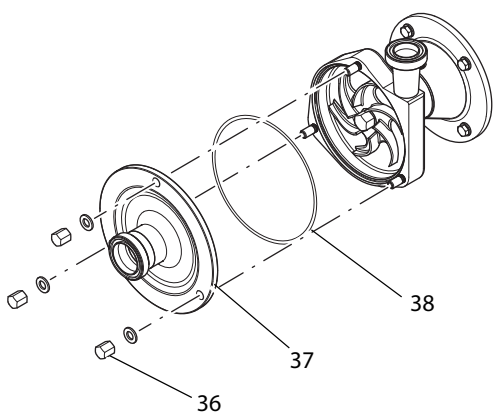

Fig. 26 Pump cover

1. Loosen the nuts (36) on the pump cover.
2. Remove the nuts, the washers, the pump cover (37), and the cover seal (38).

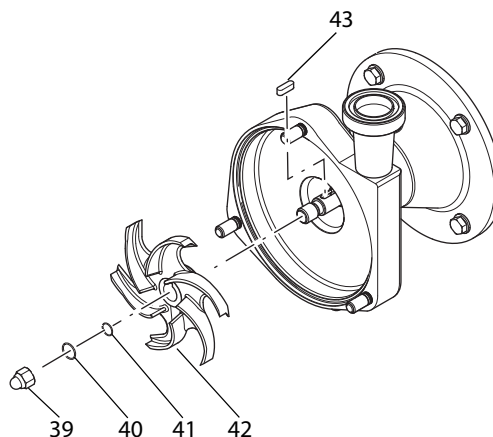

Fig. 27 Impeller

3. **WARNING:** Risk of injury when stopping the impeller by hand. Block the impeller (42) with a wooden wedge. Loosen the impeller nut (39), and remove with the O-ring (40).
4. Take the snap ring (41), the impeller (42), and the key (43) off of the shaft.
5. Only for pumps with double shaft seals: Remove the flushing tubes for sealing or quenching liquid.

TIP: For large pump casings, there is an M 12 thread on the top of the casing. An eyebolt can be screwed into the thread for suspension of the pump head from a crane.
6. Pull the pump head with the pump-side shaft seal off of the shaft as follows:
 - 6a. Clamp connection variant
 1. Loosen the clamp bolt.
 2. Slightly spread the clamp connection with a wedge.
 3. Pull the pump casing out of the clamp connection.
 - 6b. Flange connection variant
 1. Loosen the fastening screws on the flange and remove.
 2. Remove the pump casing.
7. Take the shaft seal out of the pump casing.

9.9 Checking of the Clearances

The position of the impeller is determined by the position on the shaft. The clearances are set through the position of the pump casing with respect to that of the impeller.

Note: For clearances, refer to table 6-8.

Prerequisites

- Pump casing is connected firmly to the lantern.
- Pump cover has been removed.
- The impeller has been mounted and the impeller nut tightened.

9.9.1 Measurement of the Impeller-Pump Cover Clearance

1. Measure the height H of the pump cover (44) using vernier calipers.

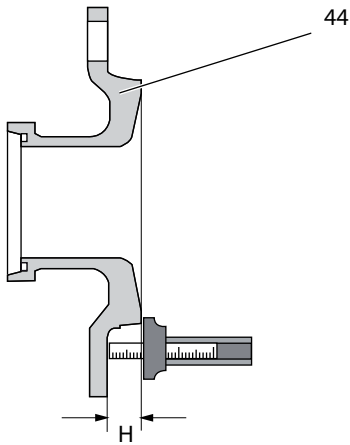

Fig. 28 Height

2. Measure the clearance A between the pump casing (45) and the impeller (46) using vernier calipers.

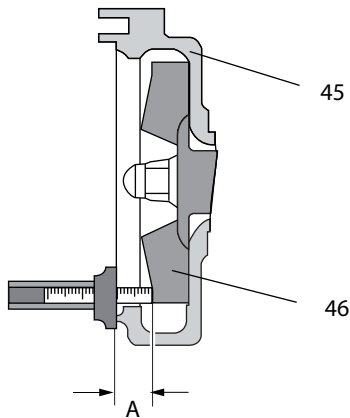

Fig. 29 Clearance

3. Calculate the clearance (clearance = A-H).
4. Adjust the clearance to the values specified in Table 6, "Standard Clearance," page 20, Table 7, "Clearances in model S," page 20 or Table 8, "Clearances in model R," page 20 respectively.

9.9.2 Measurement of the Impeller Casing Clearance / Sizes 711/712 - 1231/1232

1. Measure the clearance between the impeller and the casing using a leaf feeler gauge (Fig. 30, "Impeller-casing clearance," page 19).
2. Adjust the clearance to the values specified in Table 6, "Standard Clearance," page 20, Table 7, "Clearances in model S," page 20 or Table 8, "Clearances in model R," page 20 respectively.

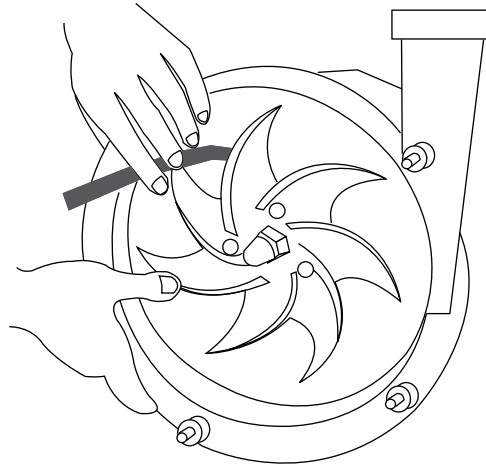

Fig. 30 Impeller-casing clearance

9.9.3 Measurement of the Impeller-Casing Clearance / size 1241/1242 or 1251/1252

1. Measure dimension B between the shaft shoulder and the pump casing (47) with a leaf feeler gauge.

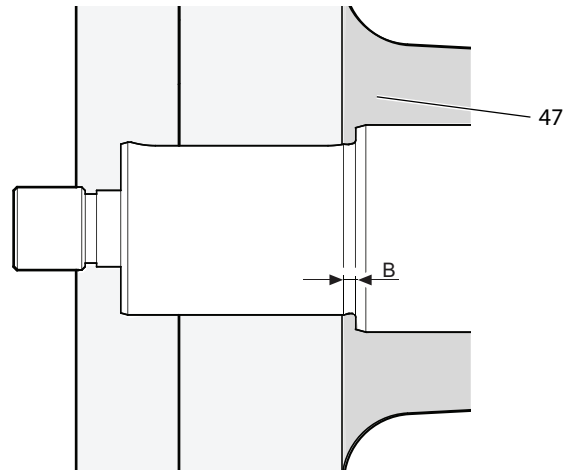

Fig. 31 Measuring the clearance between shaft shoulder and pump casing

2. Measure height F of the stationary bushing (48) with a sliding calliper.
3. Calculate the clearance (= F - B).

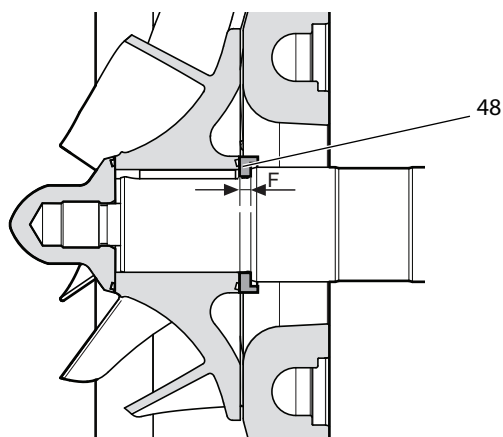

Fig. 32 Measuring the stationary bushing

- Adjust the clearance to the values specified in Table 6 , "Standard Clearance," page 20, Table 7 , "Clearances in model S," page 20 or Table 8 , "Clearances in model R," page 20 respectively.

Clearance too large

- If the clearance between the housing and the impeller is too large, rework the stationary bushing.

Grinding stationary bushing to size

- Remove the stationary bushing from the shaft sealing kit. The location of the stationary bushing is indicated in the "Sectional drawing of shaft seal" in the appendix of the "Order documents".
- Grind the stationary bushing to the required size.
- Re-install the stationary bushing.
- Slide the key and the impeller onto the shaft and tighten them with the impeller nut.
- Measure the clearance again.

Pump Size	Clearances in mm	
	Impeller–Pump Cover	Impeller–Casing
711/712	0.5	0.5
721/722	0.5	0.7
741/742	0.5	0.5
751/752	1.0	1.0
7451/7452	0.8-0.9	1.0
3401/3402	0.5	0.5
3521/3522	0.5	0.5
3531/3532	0.5	1.5
3541/3542	1.0	1.0
3451/3452	1.0	1.0
3551/3552	1.0	1.0
1151/1152	2.0	2.0
1231/1232	-	1.5

Table 6 Standard Clearance

Pump Size	Clearances in mm	
	Impeller–Pump Cover	Impeller–Casing
1241/1242	-	1,0
1251/1252	-	1.5

Table 6 Standard Clearance

- If the code "S" or "R" (additional letter 1) is printed on the rating plate, adjust the clearance to the values specified in Table 7 , "Clearances in model S," page 20 or Table 8 , "Clearances in model R," page 20 respectively. (Position of additional letter 1: See Chapter 3.3, "Pump Key," page 9)

Pump Size	Clearance FPS in mm	
	Impeller / pump cover	Impeller / casing (calculated)
711/712	0,5	(5,5)
721/722	0,5	(5,5)
741/742	0,5	(5,5)
751/752	1.0	(5,0)
3521/3522	0,5	(10,5)
3531/3532	0,5	(11)
3541/3542	1,0	(11)
3551/3552	1,0	(11)

Table 7 Clearances in model S

Pump Size	Clearance FPR in mm	
	Impeller / pump cover (calculated)	Impeller / casing
3521/3522	(10,5)	0,5
3531/3532	(11)	0,5
3541/3542	(11)	1,0
3551/3552	(11)	1,0

Table 8 Clearances in model R

9.10 Pump Head Attachment

The pump assembly is dependent on the respective pump size and model as well as the respective shaft seal (see "Order-Related Documents") in the attached documents.

NOTICE

Incorrect Elastomers

Pump leakiness.

- Ensure that the elastomers are appropriate for the condition of the pumping medium. Please refer to the "Order-Related Documents".

Preparation

- Clean all pump parts and check for damage and accuracy of fit.
- If necessary, rework or replace pump parts.

- ▶ Assemble in clean conditions, carefully, and using little force. The seals could be permanently deformed or break in part.
- ▶ Replace all O-rings.
- ▶ To reduce friction, wet the O-rings and the sliding faces with water, alcohol, or silicone grease.
- ▶ Clean the sealing surfaces of the mechanical seals with a degreaser, e.g., OKS 2610 Universal Cleaner. Do not allow the sealing surfaces to come into contact with oil or grease and do not touch with your fingers afterwards.

Tip: The joint retaining compound "Euro Lock A64.80," e.g., is suitable for gluing in bearings and bushings.

Tip: The screw retaining compound "Euro Lock A24.10," e.g., is suitable for gluing in set screws.

9.10.1 Clearance Setting for Flange Connection

Note: For pumps with flange connections, the clearance is set using shims. To determine the exact number and thicknesses of shims needed, first mount the impeller nut, the impeller, and the key as follows and then remove again.

1. Slide the pump casing (49) and the shims (50) over the shaft to the flange (51) and screw on.

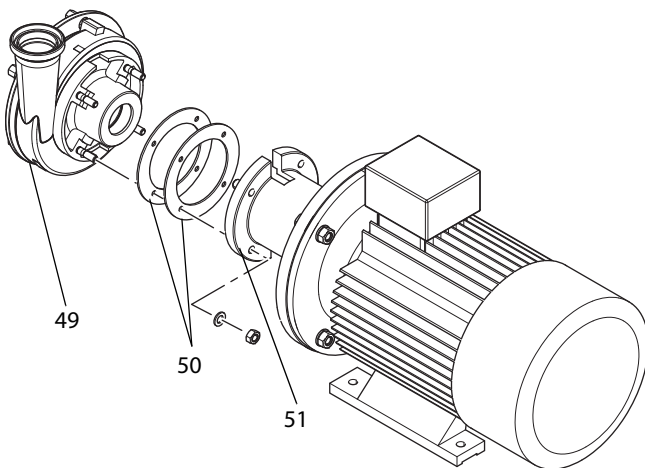

Fig. 33 Setting the clearance for the flange connection

2. Slide the seal driver onto the shaft.
3. Slide the key and the impeller onto the shaft.
4. Tighten the impeller nut.
5. Check the clearances (see Chapter 9.9, "Checking of the Clearances," page 18).
6. Remove the impeller nut, the impeller, and the key.
7. Remove the pump casing.
8. If the clearance is incorrect:
 - ▶ Adjust the clearance using the appropriate shims.

9.10.2 Mounting of Seals

The shaft seal built into the respective pump is given in the attached documents in the "Order-Related Documents" in the form of a "Sectional Drawing" and a "Replacement Parts List".

The part numbers in this chapter correspond to DIN 24250.

The assembly of standard shaft seals is described in the following sections with the application cases A to F. The version for your order can deviate from this.

If anything is unclear or if you require further information, please contact *Fristam*.

Applica-tion Case	Pump	Shaft Seal	Pump Sizes
A	FP/FPE	Single	340/350/700/1150/1230
B	FP/FPE	Single	1240/1250
C	FPE	With quench	340/350/700, with clamp connection: ø 60 mm
D	FPE	With quench	340/350/740, with clamp connection: ø 100 mm 1150/1230/750, with flange connection
E	FP/FP...V	Double	340/350/700/1150/1230
F	FP/FP...V	Double	1240/1250

Table 9 Standard shaft seals

Application Case A

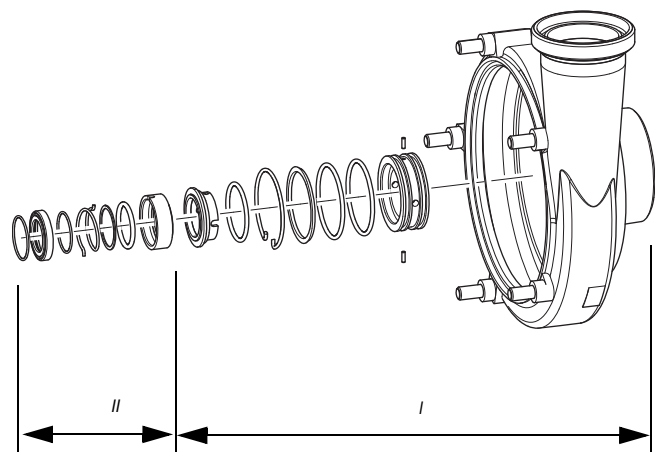

Fig. 34 Application case A

In the above figure, parts are grouped according to assembly steps:

I	Preassembly of the pump casing
II	Completion of assembly on the shaft

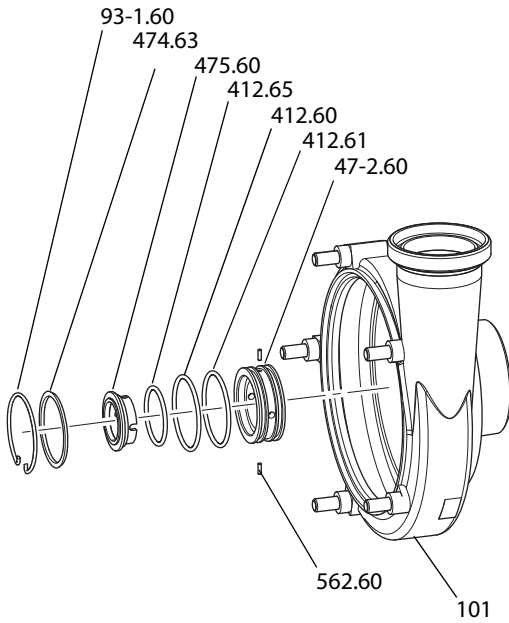

Fig. 35 Application case A, preassembly of the pump casing

To preassemble the pump casing (I):

1. Glue the cylindrical pin (**562.60**) into the mechanical seal chamber (**47-2.60**) with a retaining compound.

Note: Glue the cylindrical pins into the mechanical seal chamber so that they do not touch the shaft when the unit is fully assembled. Ensure that the cylindrical pins are fully engaged in the bores of the stationary seal ring (**475.60**). If the stationary seal ring does not feature holes, the cylindrical pins must engage in the longitudinal recesses in the stationary seal ring (see "Sectional drawing of shaft seal").

2. Place O-rings (**412.60**) and (**412.61**) into the mechanical seal chamber.
3. Guide the preassembled mechanical seal chamber into the pump casing (**101**).
4. Place the thrust collar (**474.63**) on the pump casing and secure with snap ring (**93-1.60**).

Preassembly of the pump casing is now finished.

5. Equip the stationary seal ring (**475.60**) with an O-ring (**412.65**).
6. Guide the stationary seal ring into the mechanical seal chamber.

Note: Guide in so that the cylindrical pins on the mechanical seal chamber engage in the slots on the stationary seal ring.

Preassembly of the mechanical seal chamber is now finished.

7. Mount the preassembled pump casing (**101**) on the shaft as described in Chapter 9.10.3, "Mounting of the Pump Casing," page 25.

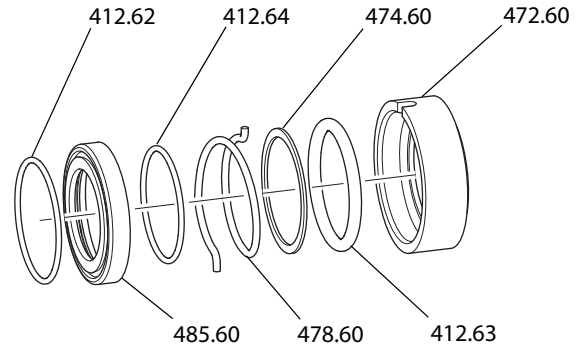

Fig. 36 Application case A, completion of assembly on the shaft

To complete assembly on the shaft (II):

8. Equip the rotating seal ring (**472.60**) with an O-ring (**412.63**).
9. Equip the seal driver (**485.60**) with O-rings (**412.62**) and (**412.64**).
10. Slide the rotating seal ring with the thrust collar (**474.60**), the spring (**478.60**), and the seal driver onto the shaft. Let the folded end of the spring snap into the rotating seal ring.
11. Finish the assembly of the shaft seal by attaching the impeller; see Chapter 9.10.4, "Mounting of the Impeller," page 26.

Application Case B

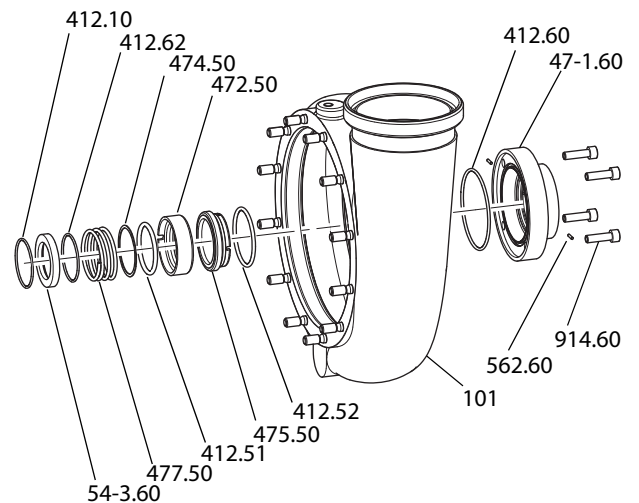

Fig. 37 Standard shaft seal: application case B

To preassemble the pump casing:

1. Glue the cylindrical pin (**562.60**) into the mechanical seal chamber (**47-1.60**) with a retaining compound.

Note: Glue the cylindrical pins into the mechanical seal chamber so that they do not touch the shaft when the unit is fully assembled. Ensure that the cylindrical pins are fully engaged in the bores of the stationary seal ring (**475.50**). If the stationary seal ring does not feature holes, the cylindrical pins must engage in the longitudinal recesses in the stationary seal ring (see "Sectional drawing of shaft seal"). Insert the O-ring into the mechanical seal chamber.

2. Insert the O-ring (**412.60**) into the mechanical seal chamber.

3. Use socket screws (**914.60**) to fasten the mechanical seal chamber to the pump casing (**101**).
4. Equip the stationary seal ring (**475.50**) with an O-ring (**412.52**) and guide into the mounted mechanical seal chamber on the pump side.

To complete assembly on the shaft:

5. Slide the rotating seal ring (**472.50**) with the O-rings (**412.51**), (**412.62**), and (**412.10**), the thrust collar (**474.50**), the spring (**477.50**), and the seal driver (**54-3.60**) onto the shaft. Let the folded end of the spring snap into the rotating seal ring.
6. Finish the assembly of the shaft seal by attaching the impeller; see Chapter 9.10.4, "Mounting of the Impeller," page 26.

Application Case C

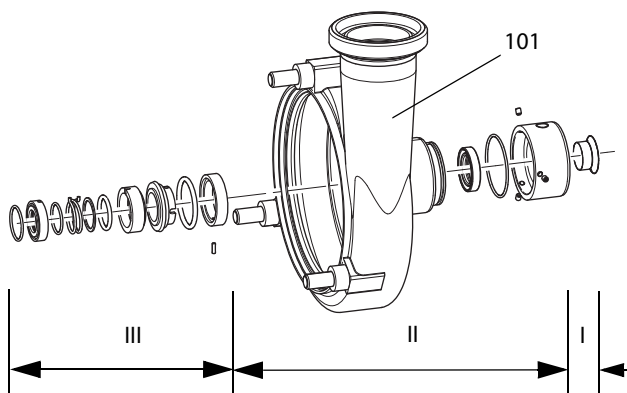

Fig. 38 Application case C

In the above figure, parts are grouped according to assembly steps:

I	Preassembly on the shaft
II	Preassembly of the pump casing
III	Completion of assembly on the shaft

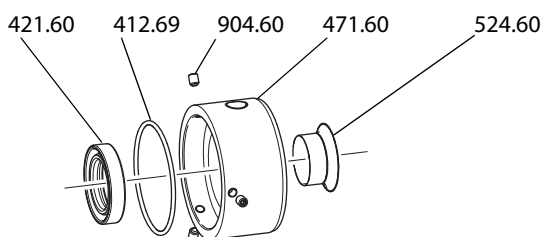

Fig. 39 Application case C, preassembly on the shaft (I) and preassembly of the pump casing (II)

To preassemble on the shaft (I):

1. **Caution!** Cutting injuries from sharp-edged shaft protective sleeves. Wear suitable protective gloves.
 - ▶ Slide the shaft protective sleeve (**524.60**) onto the shaft using an assembly tool (auxiliary pipe). Position on the shaft: See "Sectional Drawing".

Preassembly of the shaft is now finished.

To preassemble the pump casing (II):

2. Insert an O-ring (**412.69**) into the groove on the pump casing (**101**).
3. Insert the rotary shaft seal (**421.60**) into the seal cover (**471.60**).

Note: Heed the installation direction for the rotary shaft seal. See "Sectional Drawing".

4. Slide the seal cover onto the pump casing on the motor side. Align the drill holes for the sealing liquid connections vertically.
5. Apply a screw retaining compound to the set screws (**904.60**) and fasten the seal cover.

Preassembly of the pump casing is now finished.

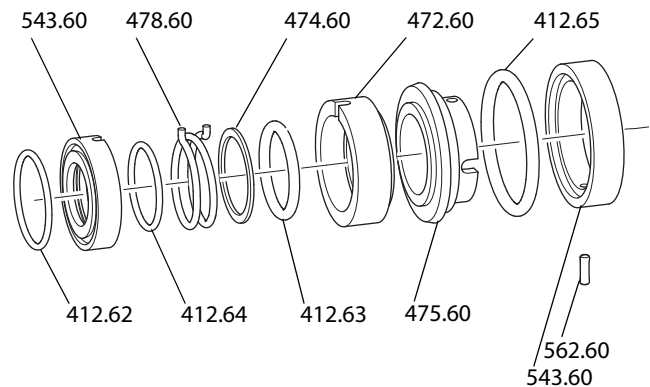

Fig. 40 Application case C, completion of assembly on the shaft (III)

To complete assembly on the shaft (III):

6. Apply a retaining compound to the cylindrical pin (**562.60**), and glue cylindrical pin into the spacer bushing (**543.60**).

Note: Glue the cylindrical pins into the spacer sleeve so that they do not touch the shaft when the unit is fully assembled. Ensure that the cylindrical pins are fully engaged in the bores of the stationary seal ring (**475.60**). If the stationary seal ring does not feature holes, the cylindrical pins must engage in the longitudinal recesses in the stationary seal ring (see "Sectional drawing of shaft seal").

7. Use a retaining compound to glue the spacer bushing into the seal chamber of the pump casing (**101**).
8. Mount the pump casing. See Chapter 9.10.3, "Mounting of the Pump Casing," page 25.
9. Equip the stationary seal ring (**475.60**) with an O-ring (**412.65**).
10. Slide the stationary seal ring onto the shaft so that the cylindrical pin on the spacer bushing engages in the slot on the stationary seal ring.
11. Equip the rotating seal ring (**472.60**) with an O-ring (**412.63**).
12. Equip the rotating seal ring with the thrust collar (**474.60**) and the spring (**478.60**) and slide onto the shaft. Let the folded end of the spring snap into the slot on the rotating seal ring.
13. Equip the seal driver (**543.60**) with O-rings (**412.64**) and (**412.62**) and slide onto the shaft.

14. Finish the assembly of the shaft seal by attaching the impeller; see Chapter 9.10.4, "Mounting of the Impeller," page 26.

Application Case D

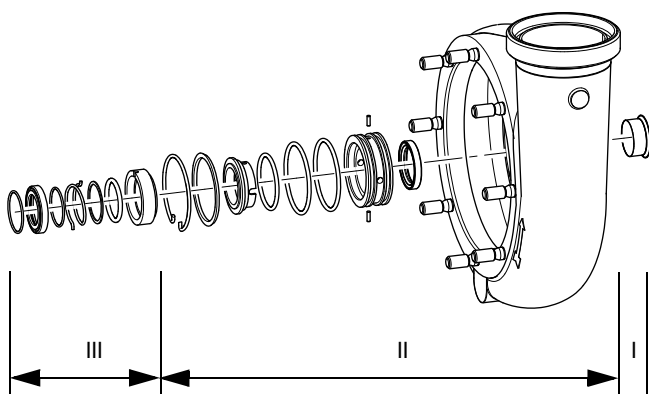

Fig. 41 Application case D

In the above figure, parts are grouped according to assembly steps:

I	Preassembly on the shaft
II	Preassembly of the pump casing
III	Completion of assembly on the shaft

To preassemble on the shaft (I):

- Caution!** Cutting injuries from sharp-edged shaft protective sleeves. Wear suitable protective gloves.
 - Slide the shaft protective sleeve (524.60) onto the shaft using an assembly tool (auxiliary pipe). Position on the shaft: See Sectional Drawing.

Preassembly of the shaft is now finished.

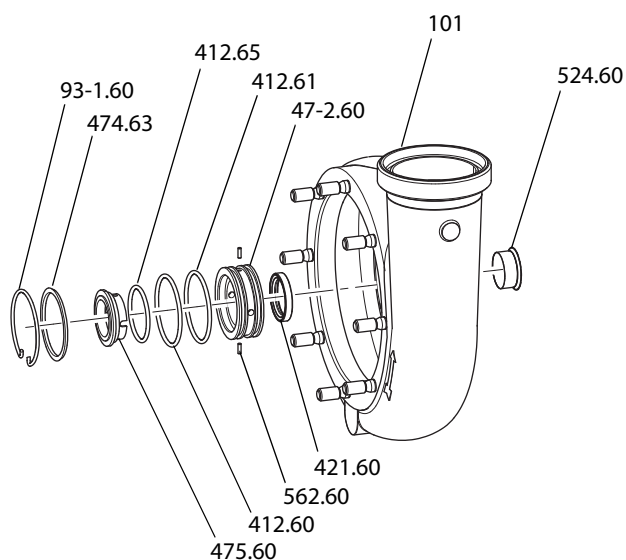

Fig. 42 Application case D, preassembly on the shaft (I) and preassembly of the pump casing (II)

To preassemble the pump casing (II):

- Glue the cylindrical pin (562.60) into the mechanical seal chamber (47-2.60) with a retaining compound.

Note: Glue the cylindrical pins into the mechanical seal chamber so that they do not touch the shaft when the unit is fully assembled. Ensure that the cylindrical pins are fully engaged in the bores of the stationary seal ring (475.60). If the stationary seal ring does not feature holes, the cylindrical pins must engage in the longitudinal recesses in the stationary seal ring (see "Sectional drawing of shaft seal").

- Install O-rings (412.60) and (412.61) from the outside and a rotary shaft seal (421.60) from the inside of the mechanical seal chamber.

Note: Heed the installation direction for the rotary shaft seal. See "Sectional Drawing".

- Equip the stationary seal ring (475.60) with an O-ring (412.65).
- Guide the stationary seal ring into the mechanical seal chamber and install together in the pump casing (101).

Note: The cylindrical pins on the mechanical seal chamber must engage in the slots on the stationary seal ring.

- Place the thrust collar (474.63) on the assembly in the pump casing and secure with snap ring (93-1.60).

Preassembly of the pump casing is now finished.

- Mount the preassembled pump casing (101) on the shaft as described in Chapter 9.10.3, "Mounting of the Pump Casing," page 25.

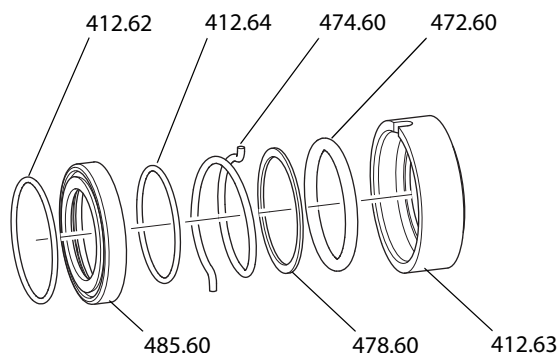

Fig. 43 Application case D, completion of assembly on the shaft (III)

To complete assembly on the shaft (III):

- Equip the rotating seal ring (472.60) with an O-ring (412.63).
- Equip the seal driver (485.60) with O-rings (412.62) and (412.64).
- Slide the rotating seal ring with the thrust collar (474.60), the spring (478.60), and the seal driver onto the shaft.

Note: Let the folded end of the spring snap into the slot on the rotating seal ring.

- Finish the assembly of the shaft seal by attaching the impeller; see Chapter 9.10.4, "Mounting of the Impeller," page 26.

Application Case E

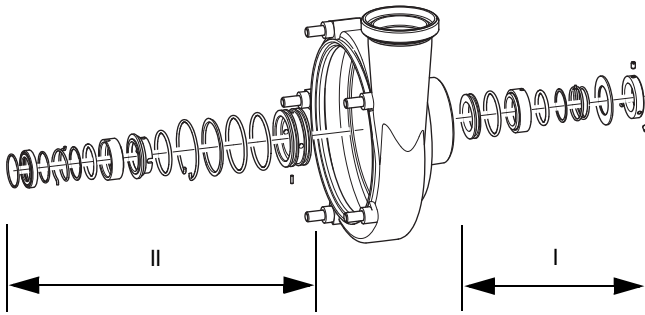

Fig. 44 Application case E

In the above figure, parts are grouped according to assembly steps:

I	Assembly of the shaft seal on the shaft on the motor side
II	Assembly of the shaft seal on the shaft on the pump side

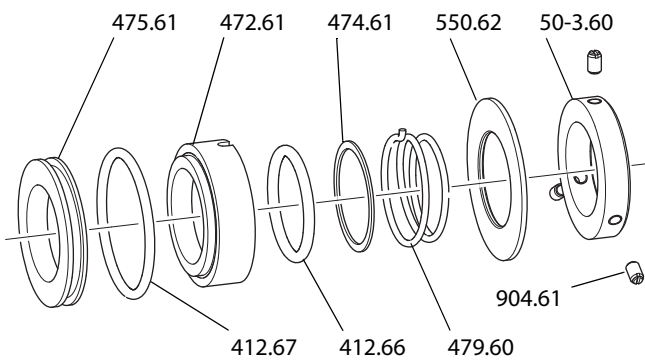

Fig. 45 Application case E, assembly of motor-side shaft seal (I)

To assemble the shaft seal on the motor side (I):

1. Only for FP...V: Secure the set collar (**50-3.60**) to the shaft using set screws (**904.61**).
Apply a screw retaining compound to the set screws. Position on the shaft: See "Sectional Drawing".
2. Slide the washer (**550.62**) onto the shaft.
3. Equip the rotating seal ring (**472.61**) with an O-ring (**412.66**).
4. Slide the spring (**479.60**) with the thrust collar (**474.61**) and the rotating seal ring (**472.61**) onto the shaft. Let the folded end of the spring snap into the slot on the rotating seal ring.
5. Mount the pump casing; see Chapter 9.10.3, "Mounting of the Pump Casing," page 25.
6. Insert the O-ring (**412.67**) into the stationary seal ring (**475.61**) and insert into the mechanical seal chamber (**47-2.60**).

Assembly of the shaft seal on the motor side is now finished.

To assemble the shaft seal on the pump side (II):

7. To assemble the shaft seal on the pump side, proceed as described in Chapter, "Application Case A," page 21.

Application Case F

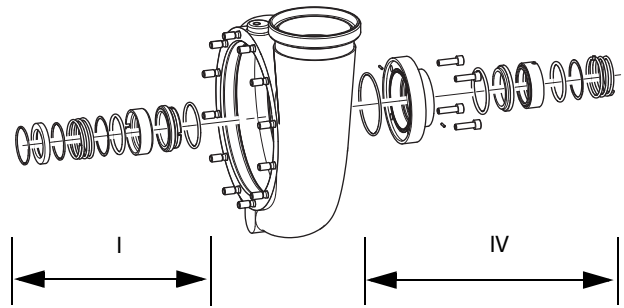

Fig. 46 Standard shaft seal, application case F

I	Pump-side shaft seal
IV	Motor-side shaft seal

To assemble the motor-side shaft seal (IV) on the shaft:

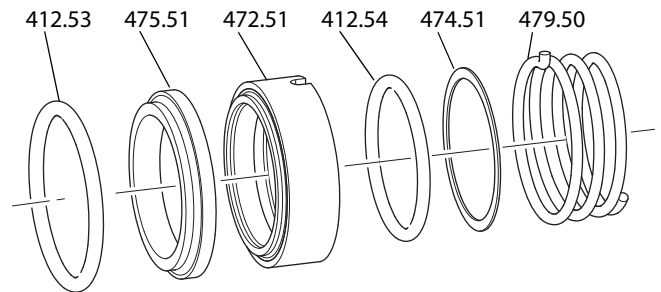

Fig. 47 Motor-side shaft seal (IV), application case F

- Slide the spring (**479.50**) with the thrust collar (**474.51**), the O-ring (**412.54**), the rotating seal ring (**472.51**), the stationary seal ring (**475.51**), and the O-ring (**412.53**) onto the shaft. Let the folded end of the spring snap into the rotating seal ring.

To assemble the pump-side shaft seal (I):

- Assemble the pump-side shaft seal (I) as described in Chapter, "Application Case B," page 22.

9.10.3 Mounting of the Pump Casing

Pump With Flange Connection

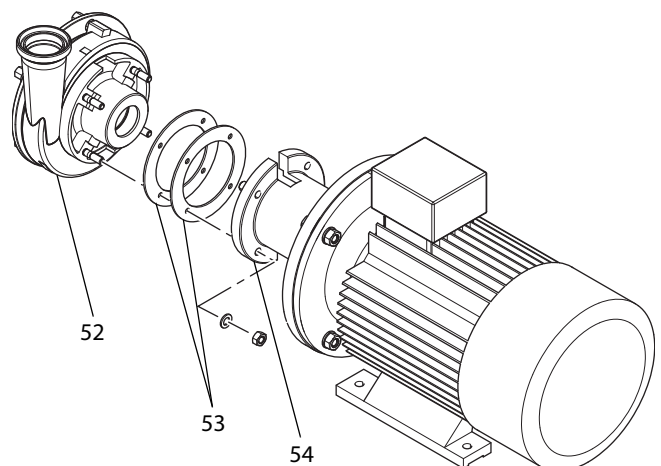

Fig. 48 Mounting of the pump casing with a flange connection

- ▶ Slide the preassembled pump casing (52) with the shims (53) over the shaft to the flange (54) and screw on (see Chapter 10.1, "Specifications," page 28).

Pump With Clamp Connection

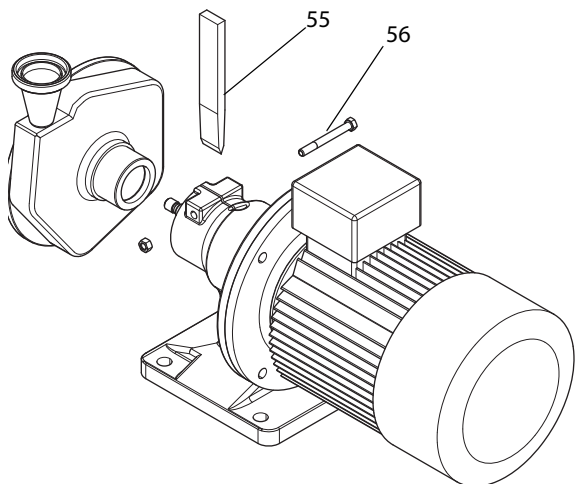

Fig. 49 Mounting of the pump casing with a clamp connection

1. Slightly spread the clamp connection with a wedge (55).
2. Only for double shaft seal: Slide the motor-side seal set onto the pump shaft.
3. Install the entire shaft seal housing with seals into the pump casing and secure to prevent slippage.
4. Slide the pump casing over the pump shaft into the clamp connection and slightly tighten the clamp bolt (56).
5. Slide the pump-side seal set onto the shaft.
6. Insert the key, the slotted plastic ring, and the impeller.
7. Insert the O-ring into the impeller nut, block the impeller to prevent it from twisting, and tighten the impeller nut.

Thread	Tightening Torque
M16	100 Nm
M24	200 Nm

Table 10 Tightening torques for impeller nuts

8. Adjust the clearances by sliding the pump head inside the clamp connection (see Chapter 9.9, "Checking of the Clearances," page 18). Align the surface of the outlet side (discharge line connection) horizontally while doing so.
9. Tighten the clamp bolt (56):

	Thread	Tightening Torque
Special motor	M10	36 Nm
Standard motor	M10	45 Nm
	M12	75 Nm

Table 11 Tightening torques for clamp connection

10. Continue with Chapter 9.10.5, "Pump Sealing," page 26.

9.10.4 Mounting of the Impeller

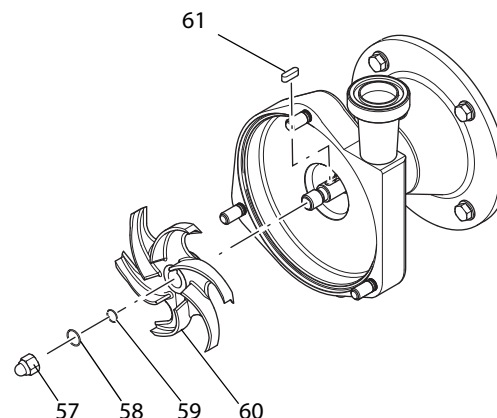

Fig. 50 Mounting of the impeller

1. Force open the plastic snap ring (59) and insert into the shaft groove.
2. Slide the key (61) and the impeller (60) onto the shaft.
3. **Caution:** Risk of injury when stopping the impeller by hand.
 - ▶ Block the impeller with a wooden wedge.
4. Screw the impeller nut (57) with the O-ring (58) onto the shaft and tighten (tightening torque = 100 Nm).

9.10.5 Pump Sealing

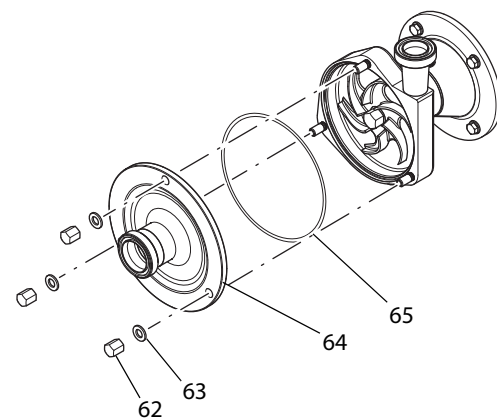

Fig. 51 Pump cover

- ▶ Slide the pump cover (64) with the O-ring (65) onto the pump casing and screw on with washers (63) and nuts (62).

9.11 Models FPE and FP..V: Mounting and Alignment of the Pump Shaft

Note: After the IEC motor has been replaced the pump shaft must be mounted and aligned.

⚠ CAUTION

Rotating Parts

Bruising and serious injuries.

- ▶ Turn off the motor and prevent it from being able to be turned on accidentally.

1. Take the key out of the motor shaft pin.
2. For electric motors with outputs higher than 30 kW: Insert the supplied half-key.
3. Degrease the motor shaft pin and the drill hole on the pump shaft using a cleaner, e.g., OKS 2610 Universal Cleaner.
4. Grind the motor shaft pin and the edges of the key slot with grinding paper to eliminate unevenness and burrs.
5. Apply a sealing gel, e.g., Stucarit 309, to the motor shaft pin in the region of the shaft shoulder.
6. Slide the pump shaft with the shrink ring onto the motor shaft pin up to the shaft shoulder.
7. Tighten the screws crosswise on the shrink ring:

Thread	Tightening Torque
M5	6 Nm
M6	12 Nm
M8	30 Nm

8. Attach the dial gauge onto the pump shaft to check the run-out tolerance.

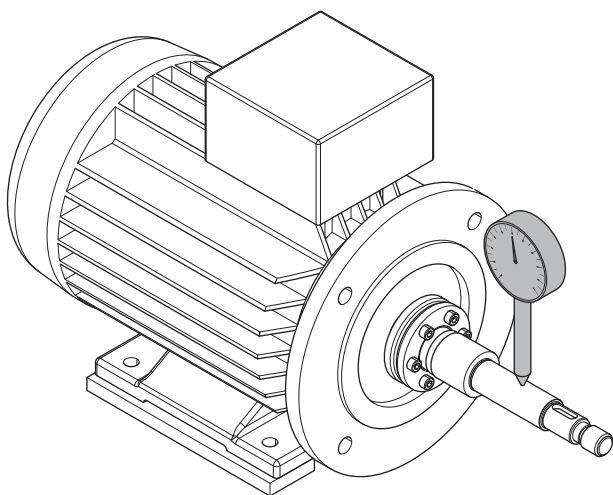

9. Check the runout of the pump shaft as a function of motor output.
 - Motor < 30 kW: max. runout tolerance = 0.06 mm
 - Motor > 30 kW: max. runout tolerance = 0.08 mm

10. Straighten the pump shaft if necessary.

9.12 Model L: Coupling Replacement

Only use couplings approved by *Fristam*. The coupling must be appropriate for the characteristic curve of the pump. If you have any questions, please contact *Fristam*.

Procedure

1. Turn off the motor and prevent it from being able to be turned on accidentally.
2. Remove the coupling guard.
3. Remove the coupling tire.
4. Detach the motor from the base frame or the foundation and remove.
5. Dispose of the old coupling parts in an environmentally friendly manner.
6. Place new coupling parts (tires, flanges, possibly clamping rings) on the drive shaft and on the gear shaft.
7. Place the motor on the base frame or the foundation and slightly tighten the fastening screws.
8. Check the parallel and angular misalignment of the shafts.

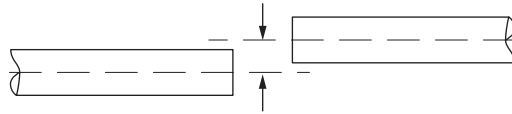

Fig. 52 Parallel misalignment

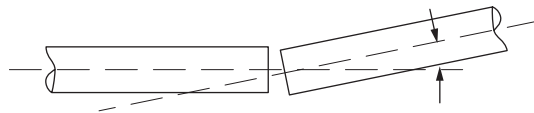

Fig. 53 Angular misalignment

9. Minimize deviations from the angular and parallel misalignment. Realign the shafts if necessary.
10. Screw the motor to the base frame or the foundation.
11. For information on the spacing between the two coupling flanges, please see the coupling installation manual. See "Supplier Documentation" in the attached documents.
12. Fasten the coupling flanges with the given spacing onto the shaft.
13. Fasten the coupling tire. Tighten the screws uniformly and crosswise. Heed the given tightening torques in the coupling installation manual.
14. Mount the coupling guard.

10 Appendix 1

10.1 Specifications

10.1.1 Tightening Torques for Screws and Nuts

Material: Steel, Strength Class: 8.8

Thread	M6	M8	M10	M12	M16	M20
Tightening Torque [Nm]	11	27	54	93	230	464

Material: Stainless Steel, Strength Class: 70

Thread	M6	M8	M10	M12	M16	M20
Tightening Torque [Nm]	7.4	17.5	36	62	150	303

Material: Stainless Steel, Strength Class: 80

Thread	M6	M8	M10	M12	M16	M20
Tightening Torque [Nm]	10	24	49	80	203	393

10.1.2 Noise Emissions

Pump Size	Noise Level dBA
711/712	75
721/722	71
741/742	79
751/752	78
7451/7452	78
3401/3402	71
3521/3522	74
3531/3532	79
3541/3542	78
3451/3452	81
3551/3552	81
1151/1152	89
1231/1232	79
1241/1242	89
1251/1252	92

Table 12 Noise emissions

The specified values apply to operation of the pump at the best efficiency point (see "Pump Characteristic Curve"). The noise level can differ greatly at other working points.

10.2 Maintenance Intervals¹

Model	Interval	Maintenance Task	Chapter
All with "Sealing and Quenching Liquid" option	Once a day	Check the sealing or quenching liquid.	See Chapter 9.3, "Inspection of Sealing and Quenching Liquid (Optional)," page 15.
L 2, L 3/L3V, L 4V	Once a day	Check the oil level.	
KF1, KF 2, KF 3	5,000 h	Lubricate the shaft bearing.	See Chapter 9.5.4, "Model KF," page 16.
L 2, L 3/L3V, L 4V	5,000 h	Change the oil.	See Chapter 9.5.2, "Models L 2, L 3/L3V and L 4V," page 15.
L1	5,000 h	Lubricate the shaft bearing.	See Chapter 9.5.3, "Model L1," page 16.
All	When necessary	Replace the shaft seal.	See Chapter 9.7, "Shaft Seal Replacement," page 18.
All	When necessary	Replace the motor.	See Chapter 9.6, "Motor Replacement," page 17.
FPE/FPV	When necessary	Replace the shaft.	See Chapter 9.11, "Models FPE and FP...V: Mounting and Alignment of the Pump Shaft," page 27.
All	According to manufacturer's specifications	Lubricate the motor bearings.	See Chapter 9.4, "Lubrication of Motor Bearings," page 15.

Table 13 Maintenance intervals

¹For information on motor maintenance intervals, please see the motor operator's manual.

10.3 Troubleshooting Table

Problem	Possible Cause	Remedy
Pump either does not pump or pumps irregularly.	Suction line blocked/clogged.	Open/clean suction line.
	Suction filter contaminated.	Clean suction filter.
	Discharge-side shut-off valve closed.	Open discharge line.
	Pump not completely filled with liquid.	Install pipe system so that casing is still filled with liquid when pump is off.
	Pump with geodesic suction head ¹ ; liquid level falls at standstill.	Install foot valve in suction line.
	Suction line leaky (drawing in air).	Seal suction line.
	Foot valve blocked or contaminated.	Reestablish proper function of foot valve; clean.
	Suction head too high.	Lower pump; reduce suction head.
	Air pocket in suction line.	Lay suction line at steady incline.
	Excessive air or gas in pumping medium.	Install vent valve.
	Air ingress at shaft seal.	Check shaft seal installation. Replace elastomers.
	Cavitation at impeller inlet; resistance in suction line too high; suction head too high. NPSHa values not adapted to pump.	Optimize suction line; increase inlet height; lower media temperature; contact <i>Fristam</i> .
	Flow rate too high.	Discharge-side valve opened too wide.
Discharge line diameter too large.		Reduce nominal pipe size; insert orifice plate.
Impeller diameter too large.		Trim impeller outside diameter. Reduce speed with frequency converter. Contact <i>Fristam</i> .
Flow rate too low; discharge head too low.	Selected pump too small.	Contact <i>Fristam</i> .
	Selected impeller diameter too small.	Contact <i>Fristam</i> . Replace impeller.
	Direction of rotation of motor incorrect.	Exchange connections on motor terminal box.
	Speed too low (voltage incorrect).	Correct connection according to motor rating plate.
	Nominal pipe sizes too small.	Use larger pipe diameters.
	Pipe resistances in suction and/or discharge line too high.	Optimize pipe system; reduce elbows and valves. Contact <i>Fristam</i> .
	Pipe clogged or full of deposits.	Clean pipes.
	Foreign objects/deposits in impeller.	Remove impeller and clean.
	Impeller incorrectly adjusted.	Check impeller clearance and readjust.
Density of pumping medium too high. Viscosity of pumping medium too high.	Contact <i>Fristam</i> .	
Metal noise.	Foreign objects in pump interior.	Disassemble, inspect, and repair.
	Impeller catching.	Readjust impeller clearance; tighten impeller nut using torque wrench.
	Pump/shaft seal running dry.	Immediately supply pumping medium; open suction valve.

Table 14 Troubleshooting table

Problem	Possible Cause	Remedy
Flow noise.	Operation contrary to design in overload or part-load range.	Adjust working point to design.
	Flow losses in suction line too high.	Increase nominal sizes; shorten line; prevent outgassing.
	Cavitation.	Check condition for NPSH rating; contact <i>Fristam</i> .
Vibrations.	Suction and discharge lines stressing pump impermissibly.	Support pipes so that pump is not stressed; possibly install vibration dampers; keep water hammers away from pump.
Excessive heating of shaft bearing.	Bearing damage.	Replace bearing.
Motor power consumption too high.	Flow rate too high.	Throttle discharge line or reduce speed with frequency converter.
	Impeller diameter too large.	Trim impeller diameter; contact <i>Fristam</i> .
	Viscosity and/or density of pumping medium too high.	Contact <i>Fristam</i> .
	Massive damage to shaft bearing; shaft deformed.	Disassemble, inspect, and have repaired by <i>Fristam</i> .
Leakage at shaft seal.	Impeller nut loose.	Remove impeller; inspect shaft shoulder. Check shaft seal; tighten impeller nut to required torque; possibly replace part.
	Shaft seal or rotary shaft seal mechanical damage/wear.	Replace shaft seal and elastomers; possibly switch materials. Contact <i>Fristam</i> .
	Shaft seal running dry; suction head too high; pumping media temperature too high.	Increase pump inlet pressure; decrease suction head; use double shaft seal; contact <i>Fristam</i> .
	Sealing water head too high.	Adjust using throttle valve.
	Sealing water head too low.	Replace rotary shaft seal.
	Water tubes clogged (resulting in damage to rotary shaft seal); sealing water not clean.	Clean water tubes; adjust water inlet and outlet; use drinking water-quality water with temperature of max. 70°C.
	Temperature of pumping medium too high.	Contact <i>Fristam</i> ; convert to double shaft seal.

Table 14 Troubleshooting table

¹The "geodesic suction head" is the vertical distance between the suction-side liquid level and the center of the impeller.

10.4 Number Key

The general number key refers to the appended "Sectional drawings". The part numbers conform to DIN 24250.

Part Number	Name
101	Pump casing
108	Stage casing
160	Cover
13-1	Back casing panel
13-2	Housing insert
130	Casing part
132	Spacer
135	Wearing bush
154	Intermediate wall
156	Outlet side
18-1	Spherical cap bearing
18-2	Vibration damper
182	Base
21-1	Synchronizing shaft
213	Drive shaft
23-1	Rotor
26-1	Bracket for mechanical seal chamber
230	Impeller
32-1	Angular contact ball bearing
32-2	Cylindrical roller bearing
32-3	Deep groove ball bearing
32-4	Tapered roller bearing
321	Radial ball bearing
322	Radial roller bearing
325	Needle bearing
330	Bearing support
331	Bearing block
341	Drive lantern
344	Bearing support lantern
350	Bearing housing
360	Bearing cap
40-4	Half-length taper grooved pin
400	Flat seal
410	Profile seal
411	Gasket
412	O-ring
421	Rotary shaft seal
422	Felt ring
423	Labyrinth ring
433	Mechanical seal
45-1	Thrust ring
451	Stuffing box housing
454	Stuffing box ring
47-1	Spring with washer
47-2	Mechanical seal chamber
47-3	Wedge seal
47-5	Ring nut
471	Seal cover
472	Rotating seal ring
474	Thrust collar
475	Stationary seal ring
476	Stationary seal ring support

Part Number	Name
477	Mechanical seal spring
478	Right spring
479	Left spring
481	Bellows
482	Bellows support
484	Spring retainer
485	Seal driver
500	Ring
50-1	Split lock washer
50-2	V-ring
50-3.60	Set collar
504	Spacer ring
520	Sleeve
523	Shaft sleeve
524	Shaft protective sleeve
525	Spacer sleeve
54-1	Cover bushing
54-2	Bushing
54-3	Stationary bushing
540	Bushing
543	Spacer bushing
55-1	Serrated lock washer
550	Washer
551	Spacer washer
554	Washer
561	Grooved pin
56-1	Roll pin
56-2	Grooved pin with round head
560	Pin
562	Cylindrical pin
59-2	Dished-type lock washer
59-3	Shrink ring
59-4	Lantern
59-5	Membrane
642	Oil level sight glass
680	Enclosure
68-1	Support plate
68-2	Foam strip
68-3	Bracket for enclosure
68-4	Orifice plate
68-5	CF guard plate
681	Coupling guard
701	Bypass line
710	Pipe
71-1	Connection pipe
715	Hose pipe
722	Flange adapter
723	Flange
724	blind flange
733	pipe clamp
751	Valve housing
755	Valve bolt

Part Number	Name
756	Valve spring
759	Valve plate
800	Motor
801	Flange motor
87-1	Gearbox
87-2	Gear cover
87-3	Gear cap
87-4	Gear base
839	Contact
872	Gearwheel
89-1	Filler piece
89-2	Spherical cap frame
89-3	Motor Foot
89-4	Handle
89-5	Protective cap
89-6	Wheel
89-8	Flat bar steel
89-9	Motor bracket
89-10	Motor bracket
89-11	Spherical cap base support
892	Base plate
894	Console
897	Guide piece
90-1	Stud bolt
90-3	Tapered pin
90-4	Half-length taper grooved pin
90-5	Eyebolt
900	Screw
901	Hex cap screw
902	Threaded stud
903	Screw plug
904	Set screw
906	Impeller bolt
909	Adjusting screw
91-1	Slotted cheese head screw
913	Bleed screw
914	Socket screw
92-1	Star knob nut, long
92-2	Star knob nut, short
92-3	Cap nut
92-4	Rotor nut
92-5	Forcing screw
92-6	Rotor fastener
92-7	Nut with flange
920	Hex nut
921	Shaft nut
922	Impeller nut
923	Bearing nut
93-1	Snap ring
930	Retainer
931	Retaining washer
932	Snap ring

Part Number	Name
940	Key
941	Woodruff key
950	spring

10.5 EC Declaration of Conformity

The manufacturer: FRISTAM Pumpen KG (GmbH&Co.)
Kurt-A.-Körber-Chaussee 55
21033 Hamburg, Germany

declares that the following product (pump with motor):

- centrifugal pump types FP, FPE, FP...V, FPH, FPEH, FPH...V, FSPE, FSP...V, FM, FZ, FC, CF, CFE, FPM and FSM
- Positive displacement pump types: FK, FKL, FL, FL2, and FL3
- Powder mixer type: PM
- (for serial number, see cover page of operating manual)

conforms to all relevant requirements of the **EU Machinery Directive (2006/42/EC)**.

The machine also conforms to the relevant requirements laid down in the **Low Voltage Directive (2014/35/EU)** and the **EMC Directive (2014/30/EU)** No. 1935/2004 and FDA.

The above product conforms to the following standards:

- DIN EN 809:2012-10: Pumps and pump units for liquids - Common safety requirements
- DIN EN ISO 12100:2011-03: "Safety of machinery - General principles for design, risk assessment and risk reduction"

Documentation officer: Horst Helms

Telephone: +49(0)40 72556-107

Address: see manufacturer address

Hamburg, 30 October 2020



Julia Friedsch / Head of Quality Management

10.6 EG Declaration of Incorporation

The manufacturer: FRISTAM Pumpen KG (GmbH&Co.)
Kurt-A.-Körber-Chaussee 55
21033 Hamburg, Germany

declares that the following product (pump without motor):

- centrifugal pump types FP, FPE, FP...V, FPH, FPEH, FPH...V, FSPE, FSP...V, FM, FZ, FC, CF, and CFE
- Positive displacement pump types: FK, FKL, FL, FL2, and FL3
- Powder mixer type: PM
- (for serial number, see cover page of operating manual)

is an incomplete machine in accordance with the **Machinery Directive (2006/42/EC) Annex II B**.

The relevant, basic safety and health requirements of Annex I of the above-mentioned Directive have been applied and adhered to.

The incomplete machine further meets all the provisions of the Directive (EC) No. 1935/2004 and FDA.

The incomplete machine may only be put into operation when it has been determined that the machine into which the incomplete machine is to be installed complies with the Machinery Directive (2006/42/EC).

The above product conforms to the following standards:

- DIN EN 809:2012-10: Pumps and pump units for liquids - Common safety requirements
- DIN EN ISO 12100:2011-03: "Safety of machinery - General principles for design, risk assessment and risk reduction"

The manufacturer undertakes to transmit the special documentation on the partly completed machinery electronically to the national authorities when requested to do so.

The technical documentation belonging to the machine as per Annex VII Part B have been prepared.

Documentation officer: Horst Helms

Telephone: +49(0)40 72556-107

Address: see manufacturer address

Hamburg, 30 October 2020



Julia Friedsch / Head of Quality Management

11 Appendix 2 – Assembly Instructions (Optional)

11.1 Safety Instructions

These assembly instructions are addressed solely to specialized employees.

11.2 Scope

These assembly instructions apply to pumps supplied without motors (optional) and preassembled.

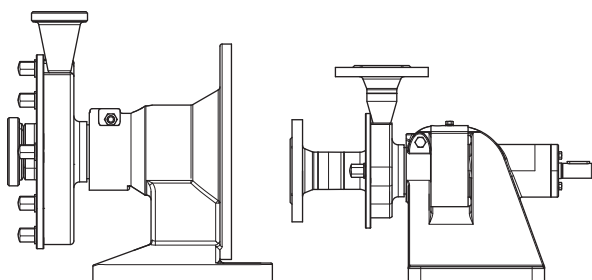

Fig. 54 Incomplete machine: pump without motor, coupling, or base frame illustrated using models KF and L

The following specifications in the "Original Operator's Manual" for complete machines do not apply in this case:

- Chapter 10.5, "EC Declaration of Conformity," page 33,
- Chapter 10.1.2, "Noise Emissions," page 28
- Chapter 2.4.4, "Rating Plate," page 6.

11.3 Rating Plate

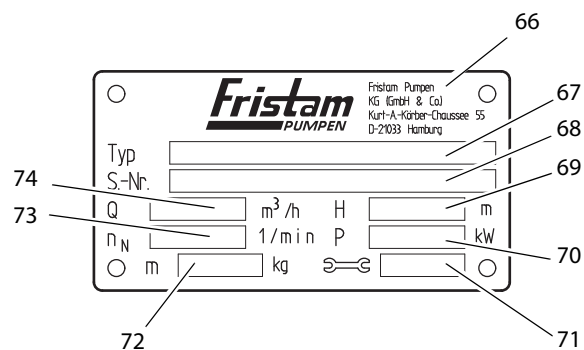

Fig. 55 Rating plate for pump without drive

66	Manufacturer
67	Type: pump series, pump size, model, version
68	SN: serial number of the pump
69	H: discharge head [m]; without drive: no indication
64	P: motor output [kW]; without drive: no indication
71	Year of manufacture
72	m: mass (pump without drive) [kg]
73	n_R : rated speed [1/min]; without drive: no indication
74	Q: flow rate [m ³ /h]; without drive: no indication

11.4 Moving Without Motor

Transportation may only be performed by trained personnel.

The pump can be moved using an industrial truck or a crane.

Always move the pump in the installation condition.

11.4.1 Safety Instructions

Falling or Unsecured Parts

Severe crush injuries.

- ▶ Always wear gloves when performing transportation-related work.

Incorrect Positioning of Pump for Transportation

Leakage of caustic, toxic, or contaminating liquids. Personal injury and material damage from contamination.

- ▶ Always move the pump in the installation condition.

Open, Unsealed Pipe Fittings

Material damage from contamination, impact, or moisture in the pump.

- ▶ Remove the pipe fitting covers just prior to connection to the pipes.

11.4.2 Moving With Industrial Trucks

⚠ WARNING

Unsecured Parts

Serious injuries from crushing, pinching of extremities, material damage.

- ▶ Before moving the pump secure it to prevent it from tipping over. Secure the pump to the pallet with tie-down straps, or screw the pump to the pallet.

Preparation

Ensure that the pump is adequately secured to the pallet, for example, with straps; see Fig. 56, "Moving with pallet truck," page 34.

Procedure

1. Pick up the pallet with the forks on the industrial truck.
2. Carefully move the pallet to the designated location and set down.

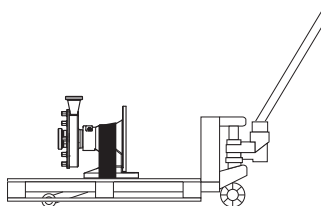

Fig. 56 Moving with pallet truck

11.4.3 Moving With Crane

⚠ WARNING

Falling Parts

Death from crushing, pinching of extremities, material damage.

- ▶ Only use suitable means of conveyance and hoists that are designed for the total weight of the pump.

Information on the pump weight can be found on the pump's rating plate as well as in the *Order-Related Documents* in the attached documents.

- ▶ Do not leave the pump in a raised position for longer than necessary.
- ▶ Ensure that the area below the pump is clear of people.

⚠ WARNING

Swinging Parts

Crushing and serious injuries.

- ▶ Start and stop the crane with pump smoothly.
- ▶ Ensure that the danger zone of the pump is clear of people.

Auxiliary Equipment

- Hoists: round slings tested in accordance with DIN EN 1492-1 and 1492-2
- Eyebolt and suitable eyebolt lifting devices

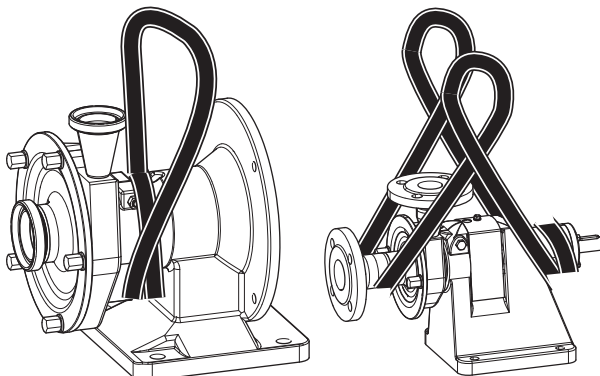

Fig. 57 Moving with crane

Preparation

- ▶ Remove load-securing devices.

To move the KF pump with the round sling:

Procedure

1. Wrap the round sling twice around the lantern neck (see Fig. 57, "Moving with crane," page 35).
2. Guide the other end of the round sling to the crane hook and hook on.
3. Position the center of gravity to ensure that the pump is lifted horizontally.
4. Lift the pump.

To move the L pump with the round sling:

Procedure

1. Wrap the round sling twice around the back end of the bearing block (see Fig. 57, "Moving with crane," page 35).
2. Lay the other end of the round sling around the suction port on the pump cover. Do not lay the round sling over any sharp edges or corners.
3. Guide both loops to the crane hook and rotate by 180° to ensure that the belt will not slip on the hook.
4. Position the center of gravity to ensure that the pump is lifted horizontally.
5. Lift the pump.

11.5 Installation Location

Please see the operator's manual *Chapter 6.2, "Installation Location," page 11* for the basic installation location requirements.

11.6 Pump Installation

11.6.1 Model KF

Prerequisites (Customer-Side)

- Suitable motor

NOTICE

Incorrectly Designed Motor

Destruction of pump.

- ▶ Only use motors that have been adapted to the pump characteristic curves. If you have any questions, please contact *Fristam*.

Procedure

1. Insert the key into the slot on the motor.
2. Slide the motor shaft into the compact bearing support.
3. Screw the motor to the compact bearing support. Tighten screws crosswise.

11.6.2 Model L

Prerequisites (Customer-Side)

- Suitable gear motor
- Adequately sized coupling
- Common installation surface for gear motor and pump so that pump shaft can be aligned with gear motor shaft

NOTICE

Incorrectly Designed Motor and Coupling

Destruction of pump and coupling.

- ▶ Only use motors and couplings that have been adapted to the pump characteristic curves. If you have any questions, please contact *Fristam*.

Note: Please see the coupling supplier documentation for reference dimensions for the coupling.

Procedure

1. Mount the coupling parts on the pump shaft and the gear shaft.
2. Place the pump on the base frame or the foundation so that the pump shaft can be connected to the gear shaft with the coupling.
3. Screw the threaded fastener slightly into the pump base.
4. Check the parallel and angular misalignment of the pump and gear shafts.
5. Minimize deviations from the angular and shaft misalignment. If necessary, realign or add shims.
6. Screw the pump and gear to the base frame or the foundation.
7. Fasten the coupling according to the coupling manufacturer's specifications.
8. Install a noncontact, barrier-providing protective device (coupling guard) in accordance with *Section 1.4, entitled "Required Characteristics of Guards and Protective Devices," of the Machinery Directive 2006/42/EC*.
9. The pump is now installed. Do not commission the pump unless the requirements of the EC Machinery Directive are met for the complete machine.

Note: Continue with *Chapter 4, "Transportation," page 9*.

Fristam Pumpen KG (GmbH & Co.)
Kurt-A.-Körber-Chaussee 55
21033 Hamburg
GERMANY

Tel.: +49-40-72556-0

Fax: +49-40-72556-166

E-mail: info@fristam.de