*English translation of the original
German Operating Manual*

Centrifugal pump FPM Series, Rotary Homogenizers FSM Series



Pump type:

Pump no.:

Copyright

© Copyright 2016 Fristam Pumpen KG (GmbH & Co.)

All rights reserved. The contents of this operating manual, including images and design, are subject to the protection of copyrights and other trade-related intellectual property rights. It is not permitted to disseminate or alter the content of this manual. Nor may the said content be copied, disseminated, altered or made available to third parties for commercial purposes.

The original version of this document is the German version.
All other languages are translations of the original version.

1	Introduction	3	7	Operation.....	10
1.1	Foreword.....	3	7.1	Safety instructions.....	10
1.2	Manufacturer	3	7.2	Commencement of Operation	10
1.3	Scope of Supply.....	3	7.3	Monitoring of Operation	11
1.4	Scope of documentation	3	7.4	Stopping of Operation	11
1.5	Display Conventions.....	3	7.5	Decommission pump.....	11
			7.6	Cleaning during operation	12
2	Safety.....	4	8	Faults.....	12
2.1	Basic safety instruction	4	8.1	Safety instructions.....	12
2.2	Intended Use	4			
2.3	Improper Use.....	4	9	Maintenance.....	12
2.4	Labels	4	9.1	Safety instructions.....	12
2.5	Noise emission	5	9.2	Replacement Parts	13
2.6	Disposal	5	9.3	Lubricating the motor bearing.....	13
			9.4	Changing the motor.....	13
3	Design and Function	5	9.5	Replacing the magnetic coupling	13
3.1	Principles of Design.....	5	9.6	Pump Head Removal.....	13
3.2	Model	6	9.7	Checking of the Clearances	14
3.3	Type designation	7	9.8	Mounting the pump head.....	16
3.4	Versions	7			
3.5	Pump Sizes	7	10	Appendix 1	18
4	Transportation.....	7	10.1	Specifications.....	18
4.1	Safety instructions	7	10.2	Maintenance intervals	18
4.2	Moving With Industrial Trucks	7	10.3	Troubleshooting table.....	19
4.3	Moving With Crane.....	7	10.4	Number Key.....	21
			10.5	EC Declaration of Conformity	22
5	Storage	8			
5.1	Safety.....	8			
5.2	Storage conditions	8			
5.3	Long-Term Storage	8			
5.4	Recommissioning	8			
6	Installation	9			
6.1	Safety instructions	9			
6.2	Installation site.....	9			
6.3	Prevention of noise and vibration	9			
6.4	Pump Fixation	9			
6.5	Electrical connection	10			
6.6	Cleaning	10			

1 Introduction

1.1 Foreword

This operation manual describes all sizes, models and versions of the FPM and FSM series.

Information on the model, size, and version of your pump can be found on the rating plate on your pump and in the "Order-Related Documents" in the attached documents.

1.2 Manufacturer

Fristam Fristam Pumpen KG (GmbH & Co.)

Kurt-A.-Körber-Chaussee 55

21033 Hamburg

GERMANY

Tel.: +49 (0) 40/7 25 56-0

Fax: +49 (0) 40/7 25 56-166

email: info@Fristam.de

1.3 Scope of Supply

The package includes the following items:

- Covers for pipe fittings
- Optional: *Fristam* accessories
- Optional: assembly kit
- Documentation
- ▶ Check the shipment for completeness and damage. Immediately notify *Fristam* of any missing items or damage.

1.4 Scope of documentation

The documentation includes the following items:

- **this operating manual,**
 - Maintenance, lubrication, and tightening torque tables can be found in the appendix 1.
- **Attached documents**
 - Order-related documents,
 - Data sheet of magnetic coupling,
 - Supplier Documentation (motor, etc.),
 - Declaration of Conformity,
 - documentation about *Fristam* accessories, if applicable,
 - certificates (materials certificates, etc.), if applicable.

1.5 Display Conventions

List items are preceded by dashes:

- Part 1,
- Part 2.

Handling instructions that must be performed in a specified order are numbered:

1. Turn device on.
2. Turn device off.

Handling instructions that do not need to be performed in a specified order are preceded by triangular bullets:

- ▶ Action.
- ▶ Action.

1.5.1 Safety instructions

▲ DANGER

A safety instruction with the signal word "Danger" indicates personal hazards causing death or serious injury.

▲ WARNING

A safety instruction with the signal word "Warning" indicates personal hazards that may lead to death or serious injury.

▲ CAUTION

A safety instruction with the signal word "Caution" indicates personal hazards that may lead to mild to moderate injuries.

NOTE

A safety instruction with the signal word "Note" warns of the possibility of material damage.

2 Safety

2.1 Basic safety instruction

- ▶ Please read this operator's manual completely before using the pump and keep it available at the pump installation location.
- ▶ Heed the applicable national regulations of the owner's country and the company's work and safety regulations.
- ▶ All work described here may only be performed by qualified experts with caution.
- ▶ Danger of contamination: Heed legal and operational safety regulations when pumping dangerous media.

2.2 Intended Use

The centrifugal pumps FPM are used to convey liquids with a dynamic viscosity of at least 0.35 mPas, up to a maximum of 1,200 mPas and media temperatures of max. 150°C / 250°C (depending on the material). The medium may contain small amounts of air or gases, it may be homogeneous and may contain minute admixtures; however, solids exceeding a size of > 0.1 mm are not permitted.

The FSM series is designed for the homogenization of fluids or mixtures. The temperature of the pumping medium can rise to a maximum 150°C / 250°C. The medium may contain small amounts of air or gases, it may be homogeneous and may contain minute admixtures; however, solids exceeding a size of > 0.1 mm are not permitted.

Each pump is designed according to customer requirements. The seal materials have been selected for the respective medium. The pump may only be used to pump the medium it was designed for (see "Order-Related Documents" in the attached documents).

2.3 Improper Use

The standard version of the FPM and FSM series must not be used in an explosive atmosphere. Special explosion-proof versions are available for this.

Pumping of media other than those specified can destroy the pump.

Pumping of foreign objects with the media can destroy the pump.

Standard pump units from *Fristam* are described in this operator's manual. If nonstandard items or extras are installed, the operator assumes the responsibility for operation.

Modifications and changes to the pump are only permitted after consultation with *Fristam*.

2.4 Labels

- ▶ Do not alter or remove the labels on the pump.
- ▶ Immediately replace damaged or lost labels with ones that are true to the originals.

2.4.1 Warning signs



Fig. 1 Safety label: "Hot surface"

This label indicates that parts can become hot during operation or, if applicable, that hot media is being pumped. Only touch the pump if you are wearing suitable gloves.



Fig. 2 Safety label: "Magnetic field"

This sign indicates that a strong magnetic field is present in some parts of the magnetic coupling. If you carry a magnetic data medium, you must remain outside a radius of 1 m to the magnetic coupling. When using magnetic parts/tools within a radius of 0.5 m, extreme caution is recommended. Due to the magnetic pull there is an inherent risk of injury and damage to the parts.



Fig. 3 Safety label: "Persons with pacemakers are not permitted beyond this point"

This sign indicates that persons with heart pacemakers implanted defibrillators are not permitted near the pump. Persons using a heart pacemaker must remain at a distance of at least 2 m to the pump.

2.4.2 No dry running

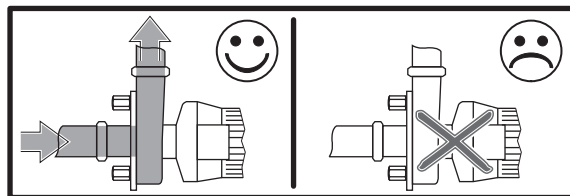

Fig. 4 Safety label: "No dry running"

This label indicates that the pump cannot be run dry. There must always be medium in the suction line and the pump when the pump is started. Otherwise the pump will be damaged.

2.4.3 Direction of rotation



Fig. 5 Label: "Impeller Direction of Rotation"

This label shows the direction of rotation of the impeller. It is located at the front on the pump cover.

2.4.4 Rating plate

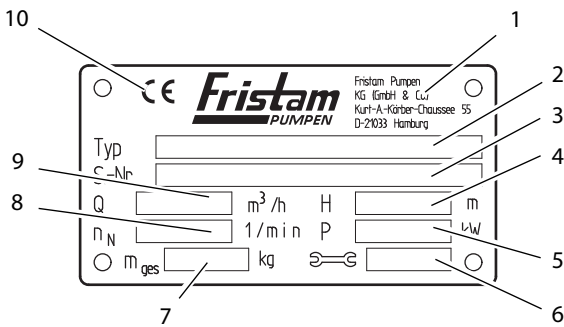

Fig. 6 Type plate for the pump unit

1	Manufacturer
2	Type: Pump series, size, model, version
3	S. no.: Serial number of the pump
4	H: discharge head [m]
5	P: Motor output [kW]
6	Year of manufacture
7	m_{tot} : Mass (total) [kg]
8	n_N : Rated speed [rpm]
9	Q: Flow rate [m^3/h]
10	CE mark

2.5 Noise emission

CAUTION

Noise Generated by Running Pump

Hearing damage.

- ▶ Wear ear protectors when using pumps specified for sound pressure levels of greater than 80 dBA.
- ▶ The local noise exposure regulations must be complied with. For noise emission values for the pumps, please see *Chapter 10.1 "Specifications", Page 18.*

2.6 Disposal

2.6.1 Disposal of Transportation Package

- ▶ Recycle the transportation package.

2.6.2 Disposal of pump

1. Carefully clean the pump. Dispose of residues in an environmentally friendly manner in accordance with applicable regulations.
2. Dismantle the pump into its constituent parts.
3. Dispose of the pump parts in an environmentally friendly manner in accordance with applicable regulations.

2.6.3 Disposal of electrical and electronic scrap

- ▶ Dispose of electrical and electronic scrap in accordance with applicable directives.

3 Design and Function

3.1 Principles of Design

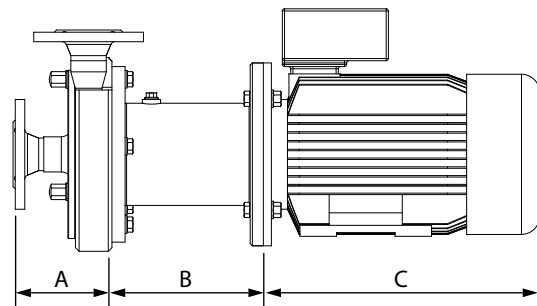

Fig. 7 Basic layout of the pumps; here the FPM model is shown as an example

A	Pump head
B	Lantern
C	Electric motor

3.1.1 Pump head (A) and lantern (B)

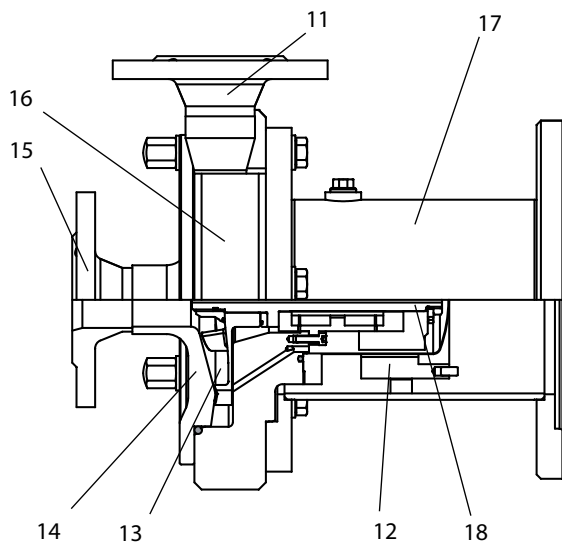

Fig. 8 Pump head and lantern

11	Discharge line connection
12	Magnetic coupling
13	Impeller
14	Pump cover
15	Suction line connection
16	Pump casing
17	Lantern
18	Pump shaft

Magnetic coupling (12)

The magnetic coupling ensures the touchless power transfer of the drive line.

Impeller (13)

- The FPM pump series uses open impellers.
- The impellers of the FSM pump series uses gears. The gears mesh with the gears of the pump cover.

The FSM pumps use drive gears exclusively with impellers.

Pump cover (14)

The connection for the suction line is located on the pump cover.

Pump casing (16)

The connection for the discharge line is located on the pump casing.

3.1.2 Electric motor (C)

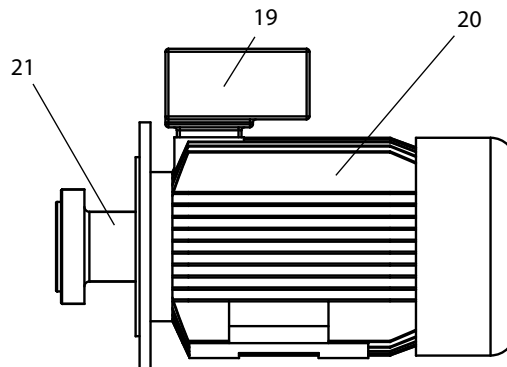

Fig. 9 Electric motor

19	Electric power connection
20	Electric motor
21	Flange shaft

Lantern (17)

The lantern connects the pump casing with the motor.

- The pump casing is screwed to the lantern via a flange connection.

Electric motor (19)

The following motor type can be mounted:

IEC standard motor with A-sided fixed bearing (drive side) with fitted key and shaft pin in models:

- IM B3/B5: Motor model with flange and base.

3.2 Model

Model FPM...V or FSM...V

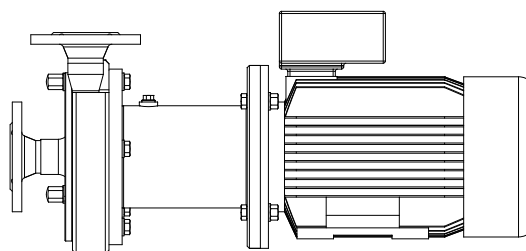

Fig. 10 Model FPM...V or FSM...V

Motor: IEC standard motor, model B3/B5

Layout: with lantern

3.3 Type designation

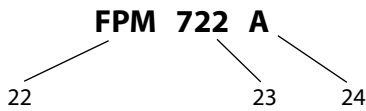

Fig. 11 Example of type designation

22	Pump type
23	Pump size
24	Symbol 2

(22) Pump type

- FPM...V Centrifugal pump
- FSM...V Rotation homogenizer

(23) Pump size

See Chapter 3.5 "Pump Sizes", Page 7.

(24) Symbol 2

A, B, C, D Versions, see Chapter 3.4 "Versions", Page 7.

3.4 Versions

Version	Enclosure	Spherical cap bases	Motor base
A	with	with	without
B	without	without	with
C	without	with	without
D	with	without	with

Table 1 Versions

3.5 Pump Sizes

Pump Sizes
711/712
721/722
741/742
3531/3532
3541/3542

Table 2 Pump Sizes

4 Transportation

Transportation may only be performed by trained personnel. The pump can be moved using an industrial truck or a crane.

4.1 Safety instructions

- Danger of injury from falling or unsecured parts.
 - ▶ Only use suitable means of conveyance and hoists. Information on pump weight can be found on the pump's rating plate as well as in the "Order-Related Documents" in the attached documents.
 - ▶ Before moving the pump secure it to prevent it from tipping over. Secure the pump to the pallet with tie-down straps, or screw the pump to the pallet.
 - ▶ Do not leave the pump in a raised position for longer than necessary.
- Leakage of caustic, toxic, or contaminating liquids.
 - ▶ Always move the pump in the installation condition.
- Damage to pump by contamination, impact, or moisture.
 - ▶ Remove the pipe fitting covers just prior to connection to the pipes.

4.2 Moving With Industrial Trucks

Preparation

- ▶ Ensure that the pump is properly secured on the pallet.

Procedure

1. Pick up the pallet with the forks on the industrial truck.
2. Carefully move the pallet to the designated location and set down.

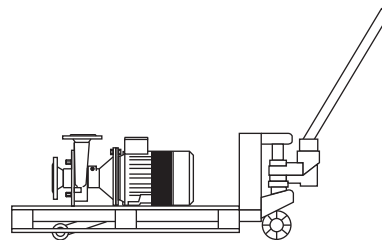

Fig. 12 Moving with industrial truck

4.3 Moving With Crane

⚠ WARNING

Falling parts

Death from crushing, pinching of extremities, material damage.

- ▶ Do not lift the pump at the eyebolts on the motor and pump casing to move because these eyebolts are not designed for the total weight.
- ▶ Only use hoists that are designed for the total weight of the pump.
- ▶ Ensure that the area below the pump is clear of people.

⚠ WARNING

Swinging parts

Crushing and serious injuries.

- ▶ Start and stop the crane with pump smoothly.
- ▶ Ensure that the danger zone of the pump is clear of people.

Auxiliary equipment

Hoists: tested round slings in accordance with DIN EN1492-1 and DIN EN1492-2.

Preparation

- ▶ Remove load-securing devices.

Procedure

1. Wrap the round sling twice around the back end of the motor. Do not lay over the fan shroud.
See Fig. 13 "Transport with round slings, FPM model shown here as an example".
2. Lay the other end of the round sling between the lantern and the pump casing. Do not lay the round sling over any sharp edges or corners.
3. Guide both loops to the crane hook and rotate by 180° to ensure that the belt will not slip on the hook.
4. Position the center of gravity to ensure that the pump is lifted horizontally.
5. Lift the pump.

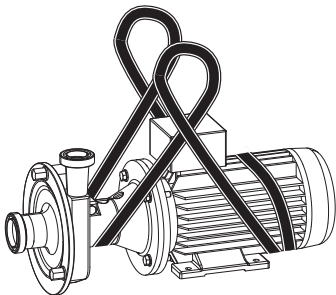

Fig. 13 Transport with round slings, FPM model shown here as an example

5 Storage

5.1 Safety

- Corrosion: Condensation can build up under a tarp and destroy the pump.
 - ▶ Ensure adequate ventilation.

5.2 Storage conditions

- ▶ Store the pump as follows:
 - Protected against frost and heat, optimally at a temperature of +20°C to +25°C
 - Dry, in low humidity
 - Ventilated
 - Dust-free

5.3 Long-Term Storage

- For a storage time of longer than six months, heed the following:
 - The impeller nut must be loosened to relax the seal and to prevent conglutination of the elastomers.
- If the storage period exceeds more than two years, the magnetic coupling must be inspected by the manufacturer. Contact Fristam if you have questions.
- ▶ All moving pump parts must be rotated every three months.

5.3.1 Elastomer Storage Conditions

- ▶ Store the elastomers as follows:
 - Storage temperature between +5°C and +20°C
 - Relative air humidity below 70%
 - No direct sunlight
 - Deformation-free storage

5.4 Recommissioning

- ▶ After long-term storage and before commissioning, check seals, bearings, and lubrication.

6 Installation

6.1 Safety instructions

- Danger of injury from falling parts.
 - ▶ Wear safety shoes.
 - ▶ Check load capacity and attachment of hoists.
- Danger of injury from unstable assembly.
 - ▶ Tighten screws to the specified tightening torque. See *Chapter 10.1.1 "Tightening torques for screws and nuts", Page 18.*
 - ▶ Use a torque wrench or an impact driver with adjustable torque.
- Material damage from swinging during adjustment of spherical cap feet.
 - ▶ Use spherical cap base plates.
- Material damage from overload.
 - ▶ Install a current limiter to protect the motor.

6.2 Installation site

For standard pumps, the installation location must meet the following requirements:

- Nonexplosive atmosphere
- Dust-free environment
- Ambient temperature: -20°C to $+40^{\circ}\text{C}$
- Moisture and salt contents in ambient air:
The values are given in the "Motor Operator's Manual." It can be found in the attached documents.
- Foundation sized adequately for the pump weight
- Horizontal and level installation surface, adequate installation surface strength for pump mass
- Installation clearances can be found in the documentation provided by the motor supplier.
- Adequate clearance for maintenance work
- Adequate air supply for motor cooling

6.3 Prevention of noise and vibration

6.3.1 Primary measures

- ▶ Operate the pump in the optimum working range.
 - Do not operate with very high flow rates. Optionally install a flow controller in the discharge line.
 - Operate the pump without cavitation. See *Chapter 6.4.1 "Installation of Pipes", Page 9.*

- ▶ Decouple the suction and discharge lines from vibrations.
 - Support lines.
 - Align lines.
 - Install vibration isolators.

6.3.2 Secondary measures

- ▶ Take structural measures such as the following:
 - Acoustic paneling
 - Enclosure in housing

6.4 Pump Fixation

Models FPM...V / FSM...V

- ▶ Versions A and C:
Set up the pump on the spherical cap bearings and align.
- ▶ Versions B and D:
Screw the pump on the motor foot to the foundation.

Carriage (Optional)

1. Set up the pump at the installation location. Lock the locks on the rollers (if present) or secure the carriage with chocks.
2. Ground the carriage to dissipate electrostatic charge.
3. Position hose line to ensure that it cannot be damaged.

6.4.1 Installation of Pipes

Lay and connect pipes as follows:

- ▶ Keep the pipe resistance as low as possible: Avoid unnecessary installation of valves, elbows, and abrupt pipe transitions.

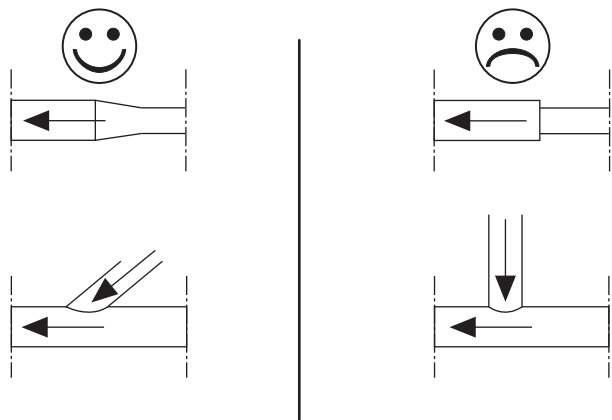

Fig. 14 Pipe transitions

- ▶ Design pipe cross section so that no unnecessary pressure losses or cavitation occurs in the suction area.
Verify this in the project planning stage.
- ▶ Suction lines must be installed horizontally or at a continuous drop towards the pump unit: Installing the pipes in the manner that will cause air bubbles or create a trough is not permitted.

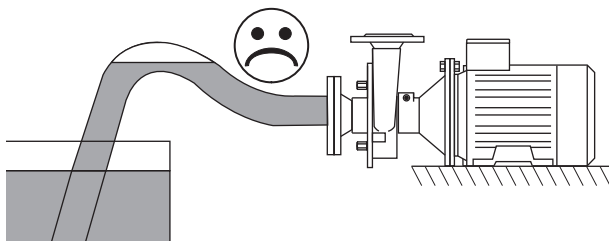

Fig. 15 Air bubbles in the pipe

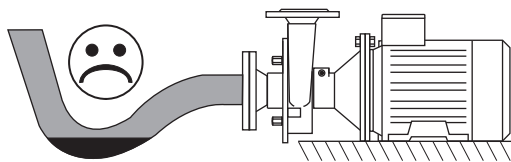

Fig. 16 Trough in the pipe

- ▶ Dimension the pipeline connections based on pressure, temperature and medium properties.
- ▶ Connect the pipes to the pump so that they are free of tension and compression to ensure that no stresses are applied to the pump.
- ▶ Secure pipes to ceilings, walls, or floor using pipe clamps.
- ▶ Align pipes flush with pump connections using a bracket.

6.5 Electrical connection

Electrical connection may only be performed by a qualified electrician.

1. Heed the connection values on the motor's rating plate. The specified voltage must not be exceeded.
2. Only connect the motor to fuse-protected circuits to prevent excessive current consumption.
3. Connect the motor according to the circuit diagram in the terminal box of the motor.
4. Protect cable feedthroughs against penetration by moisture.
5. Turn on the motor for 2 to 3 seconds and low speed. Compare the actual direction of rotation of the motor fan impeller with the arrow on the pump head.
6. Reverse the polarity if the pumping direction is incorrect.

6.6 Cleaning

Only use cleaning agents that comply with the hygiene guidelines for the respective pumping medium.

1. Before sealing the pump ensure that there are no foreign objects inside the pump or pipes.
2. Seal the pump.
3. Connect the pipes.
4. Thoroughly clean the pump and the pipe system before initial use.

7 Operation

7.1 Safety instructions

- Danger of bursting: If the allowable pressure or temperature range is exceeded, the pump may burst or become leaky.
 - ▶ Maintain the pump pressure and temperature within the specified ranges. See "Order-Related Documents" in the attached documents.
- Danger of bursting: Cold extinguishing agents used to extinguish a pump fire can cause the hot pump to burst.
 - ▶ Do not cool the pump down excessively when extinguishing the fire.
- Danger of burning: Pumping of hot media can cause the pump to become very hot.
 - ▶ Check the temperature before touching the pump.
 - ▶ Only touch the pump if you are wearing suitable gloves.
- Noise emissions: The A-weighted sound pressure level of the pumps can be greater than 80 dBA.
 - ▶ Always wear ear protectors in the vicinity of the running pump.
 - ▶ The local noise exposure regulations must be complied with.
 - ▶ See noise emission values for the pumps: *Chapter 10.1.2 "Noise emission", Page 18.*
- Pump running in reverse direction despite emergency shut-off: If the pump is shut off using the emergency shut-off function, the pumping medium in the discharge line will flow in reverse direction through the pump.
 - ▶ Install a check valve.

7.2 Commencement of Operation

NOTE

Pump runs dry

Running the pump without medium results in damage to the magnetic coupling.

- ▶ Ensure that the pumping medium always reaches the upper edge of the outlet side in the pump before and during operation.
- ▶ The pump must be vented.

NOTE

Separation of the magnetic field

Extraordinary loads during the start-up of the pump, caused by blocking of the impeller or excessive overload of the pump can cause the torque transmission of the magnetic coupling to separate. This results in extreme vibrations and excessive heating and can lead to the destruction of the magnetic coupling.

Therefore, it is essential to verify the temperature of the pump's containment shell and to observe the load monitor of the motor.

The magnetic coupling was designed based on the torque transmission and the material and was based on the operating conditions provided in the order-related data sheets. It must be ensured that the loads to which the pump is subjected during the startup, are not exceeded (see "*Design data sheet of the magnetic coupling*"; in the enclosed documents).

Procedure

1. Rinsing and cleaning the pump prior to start-up.
2. Open the valve in the suction line.
3. Close the valve in the discharge line.
4. Fill the pump and the suction line up to the top edge of the pump with medium. Allow any air bubbles to escape.
5. Observe the viscosity of the medium until the operating temperature is reached.
6. Turn on the motor.
When using magnetic couplings, a direct start is not recommended. Start the pump slowly by using a speed controlling device, or use a soft starter.

The pump conveys medium against the closed valve in the pressure line. This limits the start-up current.

7. Slowly open the valve in the discharge line and adjust to the working point.

When starting the pump, loads must be kept to a minimum; this will prevent the risk of separation of the torque transmission of the magnetic coupling.

7.3 Monitoring of Operation

During operation heed the following points:

- Shearing off of shaft: Foreign objects in the pumping medium can lead to impeller blockage and hence to shearing off of the shaft.
 - ▶ Rule out the possibility of foreign objects in the pumping medium. If necessary, install a screen, a settling tank, or a filter.
 - ▶ Install a current limiter to protect the motor.
- Damage to pumping medium: If during operation the valve in the discharge line is closed abruptly or for a long period of time, water hammers can occur in the pump. Water hammers can damage the pump and the pumping medium.

- ▶ During operation do not close the valve in the discharge line abruptly or for a long period of time.
- Damage to pump: Exceeding the rated power can lead to damage to the pump and the magnetic coupling.
 - ▶ Do not exceed the max. speed of 3,600 RPM.
- Monitoring the operating conditions: In order to prevent malfunctions or damage to the magnetic coupling, following the recommendations below is recommended:
 - ▶ Use a load monitor. This will ensure that inadmissible operating conditions such as dry running or separation of the torque transmission due to overload of the magnetic coupling can be detected very quickly.
 - ▶ Monitoring the temperature on the containment shell
 - ▶ Fluid sensor in the suction line
- Damage to motor during operation with frequency converter: If the speed is too low, the motor will overheat.
 - ▶ Please refer to the "*Motor Supplier Documentation*" in the attached documents.

7.4 Stopping of Operation

1. Turn off the motor.
2. Close the valve in the suction line to prevent the pump from running empty.
3. Close the valve in the discharge line.

7.5 Decommission pump

1. Turn off the motor.
2. Close the valve in the suction line.
3. Close the valve in the discharge line.
4. De-energize the pump.
5. Empty the pump.
6. Clean pump as described in *Chapter 6.6 "Cleaning", Page 10*.
7. Dry the pump.
8. Protect the interior of the pump against moisture, for example with silica gel.
9. Seal the pipe connections with caps to prevent penetration of dirt and foreign objects.
10. Please see *Chapter 5 "Storage", Page 8*.

7.6 Cleaning during operation

7.6.1 CIP procedure

The pumps of the FPM and FSM series are suited for CIP (Cleaning In Place) procedures. The following guidelines apply to the CIP process:

Example of a Cleaning Cycle

1. Perform preliminary flush with water.
2. Perform caustic flush with soda lye (NaOH, see Table 3 "CIP cleaning").
3. Perform intermediate flush with water.
4. Perform acid flush with nitric acid (HNO₃, see Table 3 "CIP cleaning").
5. Flush with water.

	Process temperature [°C]
NaOH (ca. 1 to 2%)	80 to 85
HNO ₃ (approx. 1%)	60 to 65

Table 3 CIP cleaning

If values deviate from these specifications, please contact *Fristam*.

7.6.2 SIP process

NOTE

Dry Running of Pump

Damage to shaft seal.

- ▶ If vapor is flowing through the pipes, ensure that the pump is off.

The pumps of the FPM and FSM series are only suited for SIP (Sterilization In Place) procedures after consultation with *Fristam*.

The suitability depends on the selection of the elastomers, the magnets and the containment shell of the magnetic coupling. The maximum process temperature is 145°C.

Temperatures with ATEX may deviate, see additional ATEX operation manual "Temperature application limit".

8 Faults

For information on faults, possible causes, and remedies, please see Chapter 10.3 "Troubleshooting table", Page 19.

8.1 Safety instructions

- Danger of burning: Pumping of hot media can cause the pump to become very hot.
 - ▶ Check the temperature before touching the pump.
- Pump running in reverse direction despite emergency shut-off: If the pump is shut off using the emergency shut-off function, the pumping medium in the discharge line will flow in reverse direction through the pump.
 - ▶ Install a check valve.

9 Maintenance

For information on maintenance intervals, please see Chapter 10.2 "Maintenance intervals", Page 18.

9.1 Safety instructions

- Danger of burning: Pumping of hot media can cause the pump to become very hot.
 - ▶ Check the temperature before touching the pump.
- Electric shock: As liquids flow through the unit, components might become electrically charged.
 - ▶ Connect the pipelines and the pump to an earthing conductor.
- Uncontrolled escaping of liquid: Before any maintenance and set-up work on the pump.
 - ▶ Close the suction and pressure valves upstream and downstream of the pump.
- Escaping liquids: Risk of corrosion and contamination.
 - ▶ Before opening the pump casing, empty the pump.
- Risk of crushing injury: During maintenance tasks, the strong magnetic field presents an inherent danger of injury.
 - ▶ During the disassembly and assembly, only studs shall be used in the casing for guiding purposes.
 - ▶ To stay out of harm's way during the assembly, and do not reach between the casing and the lantern.
- Contamination: Property damage due to contamination
 - ▶ During the disassembly and the assembly of the magnetic coupling, clean installation conditions are a primary concern.
- Damage: Damage due to excessive forces
 - ▶ Do not use excessive force during the disassembly and assembly tasks.

9.2 Replacement Parts

Use of replacement parts that are not approved by *Fristam* can lead to serious personal injury and material damage. If you have any questions regarding approved replacement parts, please contact *Fristam*.

Fristam registers all shipped pumps. The serial number of the pump is needed for ordering of replacement parts from *Fristam*; see

- rating plate or
- number stamped into pump casing.

9.3 Lubricating the motor bearing

- ▶ Lubricate the motor bearings in accordance with the motor manufacturer's specifications. See "Supplier Documentation" in the attached documents.

9.4 Changing the motor

1. Turn off the motor and prevent it from being able to be turned on accidentally.
2. Remove the pump head. See *Chapter 9.6 "Pump Head Removal", Page 13.*
3. Take the lantern off of the motor.
4. Remove the flanged shaft with outside motor from the motor shaft.
5. Replace the motor.
6. Install and tighten flanged shaft with outside motor onto the motor shaft.

Thread	Tightening torques
M10	32
M12	55
M16	135

Table 4 Tightening torques of screws/motor shaft

7. Attach the lantern onto the motor.
8. Mount the pump head. See *Chapter 9.8 "Mounting the pump head", Page 16.*

9.5 Replacing the magnetic coupling

NOTE

It is highly recommended to use *Fristam* for maintenance purposes or when replacing the magnetic coupling.

Note: The installation instructions for the magnetic coupling can be found in the magnetic coupling operating manual. In the manual can be found in the enclosed documents.

1. Disassembling the pump head, see *Chapter 9.6 "Pump Head Removal", Page 13.*
2. Disassemble the magnetic coupling, see "Magnetic coupling operating manual" in the enclosed documents.
3. Replace the magnetic coupling.
4. Pre-assemble the magnetic coupling, see "Magnetic coupling operating manual" in the enclosed document.
5. Apply Loctite 243 to all threaded connections. If the quality and properties of another brand adhesive are equivalent, this product may be used.
6. Tighten the attachment on the pump shaft, see *Table 5 "Tightening torques of screws/motor shaft", this will fix the magnetic coupling in place.*

Thread	Tightening torques
M10	32
M12	55
M16	135

Table 5 Tightening torques of screws/motor shaft

7. Attach the, contaminant shell, see "Magnetic coupling operating manual" in the enclosed document.
8. Assemble the pump head, see *Chapter 9.8 "Mounting the pump head", Page 16.*
9. Check the clearance, see *Chapter 9.7 "Checking of the Clearances", Page 14.*

9.6 Pump Head Removal

Preparation

1. Turn off the motor and prevent it from being able to be turned on accidentally.
2. Close the valve in the pressure line.
3. Close the valve in the discharge line.
4. Completely empty the pump.
5. Loosen the suction and discharge connections.
6. Take the pump out of the system.

Procedure

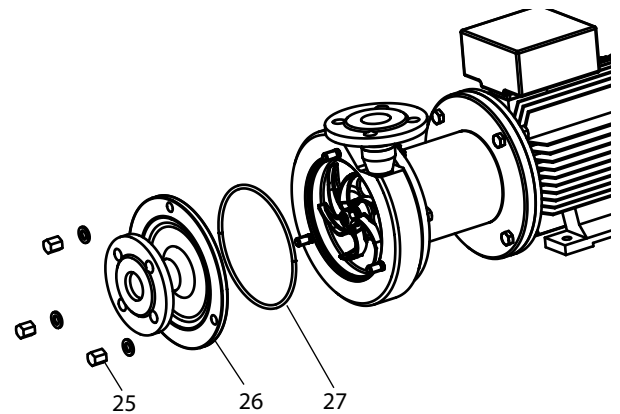

Fig. 17 Pump cover

1. Loosen nuts (**25**) on pump cover.
2. Remove the nuts, washers, pump cover(**26**) and cover seal (**27**).

Note for model FSM35, etc.: If the cover can not be loosened easily, slightly tap the cover, using a plastic hammer (mallet).

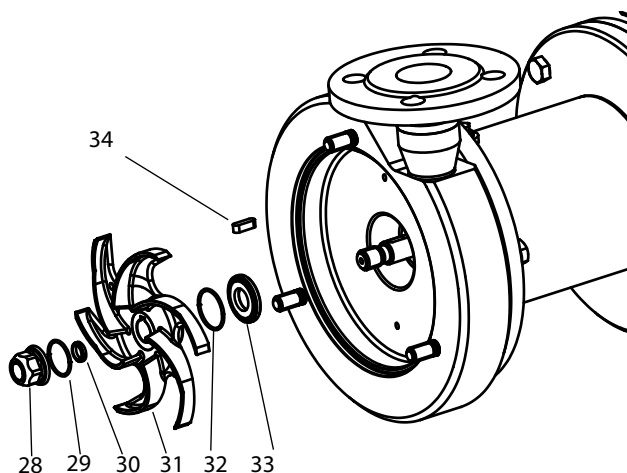

Fig. 18 Removing the impeller

3. Loosen the impeller nut (28) and remove it including the O-ring (29) :

3a. Pump type FPM

⚠ WARNING

Risk of injury when stopping the impeller by hand. Block the impeller (31) with a wooden wedge (31) .

3b. Pump type FSM

⚠ WARNING

Risk of injury when stopping the impeller by hand. Block the impeller (31) with a special tool (35) .

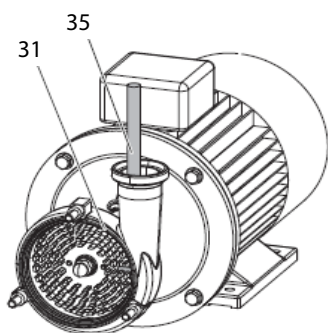

Fig. 19 Loosen the nut of the impeller

4. Remove the snap ring (30), the impeller (31) and the fitted key (34) from the shaft.

5. Remove the O-ring (32) including the stationary bushing (33).

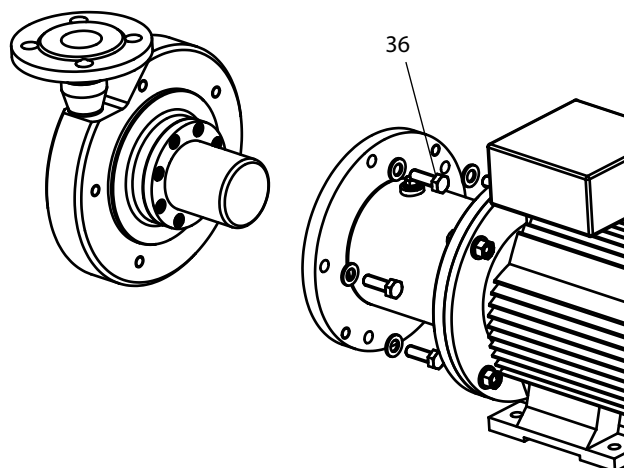

Fig. 20 Disassembling the pump casing

6. Loosen and remove the screws and washers (36).

7. Insert the 3 long studs into the casing; ensure they are evenly distributed.

Note: The studs are used to guide the casing in the lantern during the disassembly and prevent damage to the magnetic coupling.

8. Use forcing screws to separate the pump casing from the lantern.

9. Dismantle the magnetic coupling (see Chapter 9.5 "Replacing the magnetic coupling", Page 13).

Note: When disassembling the magnetic coupling, compliance with the manufacturer's instructions is mandatory (see "Magnetic coupling operating manual") in the enclosed documents.

9.7 Checking of the Clearances

The position of the impeller is determined by the position on the shaft.

Prerequisites

- Pump casing is permanently connected to lantern.
- Pump cover has been removed.
- Impeller is removed.

9.7.1 Measure the clearance of the Impeller pump cover / pump type FPM

1. Use a digital depth gage to measure distance A of the stationary bushing (38) to the pump casing (37) .

Note: Before measuring distance A, the shaft must be pulled to the front in the direction of the pump casing.

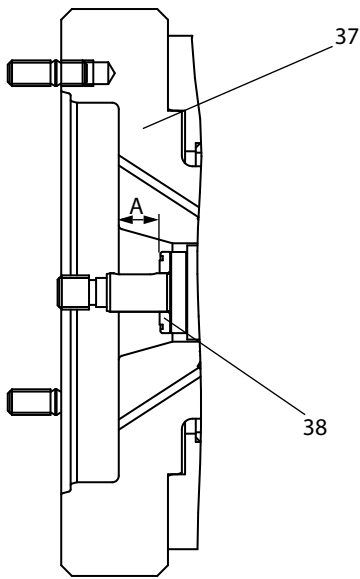

Fig. 21 Measuring the clearance stationary bushing / pump casing

- Distance B, use vernier calipers to measure the hub of the impeller.

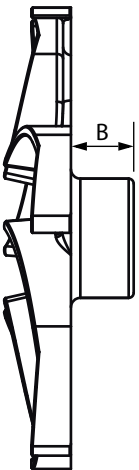

Fig. 22 Measuring the impeller

- Calculate the clearance (clearance = A – B).
- Compare clearance with Table 6 "Standard clearance".

Pump size	Clearance [mm] Impeller / pump casing
711/712	0.5
721/722	1.0
741/742	1.5
3531/3532	1.7
3541/3542	1.0

Table 6 Standard clearance

9.7.2 Measure the clearance impeller pump cover / pump type FSM

Procedure

- Measure the clearance Z between the pump casing (41) and the impeller (40) using vernier calipers.

Note: In order to measure distance Z, the impeller must be pulled to the front in the direction of the pump casing.

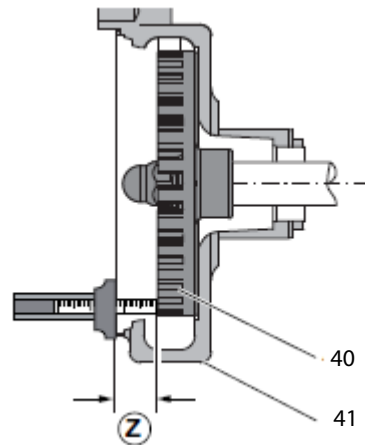

Fig. 23 Measurement of pump casing–impeller clearance

- Compare clearance Z with Table 7 "Clearance", Page 16 .

9.7.3 Measure the clearance impeller pump cover / pump type FSM

Prerequisites

- Pipe on discharge line fitting has been detached.
- Pump casing is connected firmly to the lantern.
- Impeller has been mounted without plastic snap ring (30).
- Impeller nut has been tightened.

Procedure

- Pick up the leaf feeler gauge.
- Measure the clearance inside the pipe connection (discharge line). See Fig. 24 "Measurement of impeller–pump cover clearance".

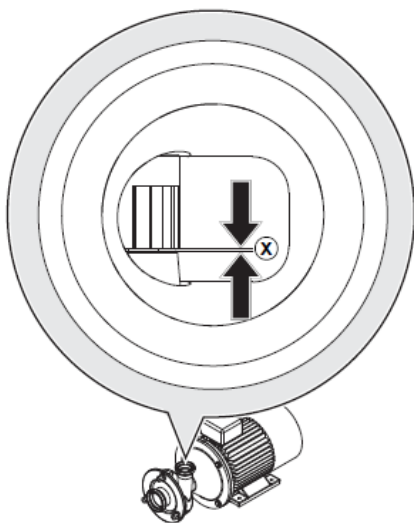

Fig. 24 Measurement of impeller–pump cover clearance

3. Compare the clearance X with Table 7 "Clearance".

Pump size	Clearance [mm]	
	z Impeller pump casing	x Impeller pump cover (resulting)
3531/3532	26.7	(1.5)

Table 7 Clearance

9.7.4 Clearance too large

- ▶ Rework the stationary bushing if the clearance between the casing and the impeller is too large.

Grinding down the stationary bushing

1. Remove the stationary bushing from the pump. The position of the stationary bushing is shown in the "Section drawing" in the "Order-related documents" in the enclosed documents.

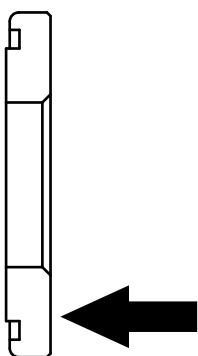

Fig. 25 Grinding down the stationary bushing

2. Grind the stationary bushing down to the proper dimension.

Note: Grind down the stationary bushing at the highlighted side, see Fig. 25 "Grinding down the stationary bushing", Page 16.

3. Install the stationary bushing.
4. Measure the clearance again.

9.8 Mounting the pump head

The mounting of the pump depends on the respective size and model as well as on the respective magnetic coupling (see "Order-related documents") in the enclosed documents.

NOTE

Incorrect elastomers

Pump leakiness.

- ▶ Ensure that the elastomers are appropriate for the condition of the pumping medium. Please refer to the "Order-related documents".

Preparation

- ▶ Clean all pump parts and check for damage and accuracy of fit.
- ▶ If necessary, rework or replace pump parts.
- ▶ Assemble carefully and using little force in clean conditions. The seals could be permanently deformed or break in part.
- ▶ Replace all O-rings.
- ▶ To reduce friction, wet the O-rings and sliding surface with water, alcohol or silicon grease.
- ▶ Clean the sliding surfaces with a cleaning agent, e.g. "OKS 2610 Universal Cleaner". Subsequently, it is recommended to coat the sliding surfaces with a few drops of oil or a small amount of grease.

Tip: The joint retaining compound "Euro Lock A64.80," e.g., is suitable for gluing in bearings and bushings.

Tip: The screw retaining compound "Euro Lock A24.10," e.g., is suitable for gluing in set screws.

Procedure

1. Assemble the magnetic coupling. see Chapter 9.5 "Replacing the magnetic coupling", Page 13.

Note: When assembling the magnetic coupling, compliance with the manufacturer's instructions is mandatory (see "Magnetic coupling operating manual") in the enclosed documents.

2. Insert the 3 long studs into the casing; ensure they are evenly distributed.

Note: The studs are used to guide the casing in the lantern during the assembly and prevent damage to the magnetic coupling.

3. Carefully push the pump casing towards the lantern.

CAUTION

To stay out of harm's way during the assembly, and do not reach between the casing and the lantern.

4. Remove the studs that are used for guiding purposes.
5. Firmly tighten the screws and washers (36).
6. Mount the impeller, see Chapter 9.8.1 "Mount the impeller", Page 17.

9.8.1 Mount the impeller

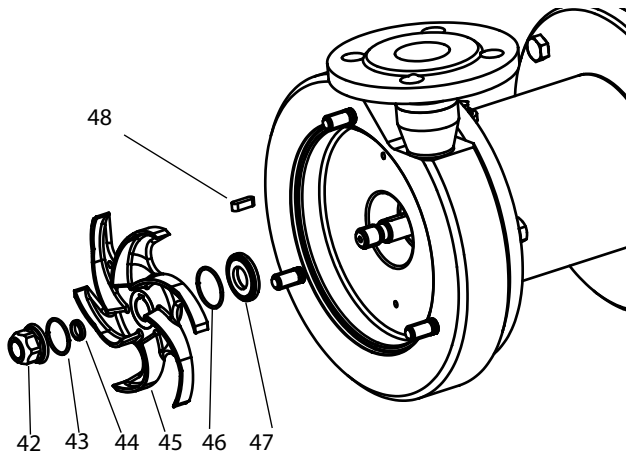

Fig. 26 Installing the impeller

1. Force open the plastic snap ring (**44**) and insert into the shaft groove.
2. Push the stationary bushing (**47**) including the O-ring (**46**) onto the shaft.
3. Slide the key (**48**) and impeller (**45**) onto the shaft.
4. Screw the impeller nut (**42**) with the O-ring (**43**) hand-tight onto the shaft.
5. Following the instructions below to tighten the impeller nut:
 - 5a. Pump type FPM

⚠ WARNING

Risk of injury when stopping the impeller by hand.

- ▶ Block impeller with a wooden wedge.

5b. Pump type FSM

Risk of injury when stopping the impeller by hand. Block the impeller (**45**) with a special tool (**49**).

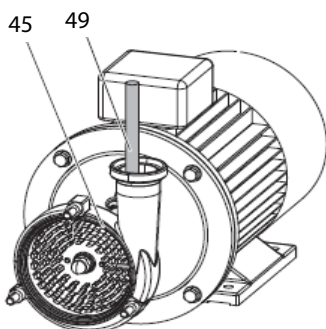

Fig. 27 Impeller nut tightening

6. Tighten the impeller nut (torque = 85 Nm).

9.8.2 Sealing the pump

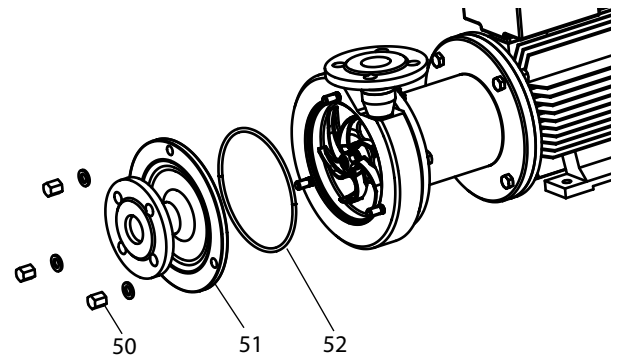

Fig. 28 Pump cover

- ▶ Push the pump cover (**51**) onto the O-ring (**52**). Tighten the nut (**50**) with the washer.

10 Appendix 1

10.1 Specifications

10.1.1 Tightening torques for screws and nuts

Material: Steel, strength class 8.8

Thread	M6	M8	M10	M12	M16	M20
Tightening torque [Nm]	11	27	54	93	230	464

Material: Stainless steel, strength class 70

Thread	M6	M8	M10	M12	M16	M20
Tightening torque [Nm]	7.4	17.5	36	62	150	303

Material: Stainless steel, strength class 80

Thread	M6	M8	M10	M12	M16	M20
Tightening torque [Nm]	10	24	49	80	203	393

10.2 Maintenance intervals

Model	Interval	Maintenance task	Chapter
All	according to manufacturer specifications	Replacing the magnetic coupling	see Chapter 9.5 "Replacing the magnetic coupling", Page 13
All	as required	change motor	see Chapter 9.4 "Changing the motor", Page 13
All	According to manufacturer specifications	lubricate motor bearing	see Chapter 9.3 "Lubricating the motor bearing", Page 12

Table 9 Maintenance intervals

For information on motor maintenance intervals, please see the "Motor subvendor documentation".

The maintenance intervals for the magnetic coupling can be found in the "Magnetic coupling subvendor documentation".

10.1.2 Noise emission

	Pump size	Noise level dB (A)
FPM	711/712	75
FPM	721/722	71
FPM	741/742	79
FPM	3531/3532	79
FPM	3541/3542	78
FSM	3531/3532	82

Table 8 Noise emission

The stated values apply for a 50 Hz mains connection and operation of the pump with the highest efficiency. The sound level might deviate significantly, depending on the working point. See "Pump characteristic" in the enclosed documentation.

10.3 Troubleshooting table

Problem	Possible cause	Remedy
Pump either does not pump or pumps irregularly.	Suction line blocked or clogged.	Open or clean suction line.
	Suction filter contaminated.	Clean suction filter.
	Discharge-side shut-off valve closed.	Open discharge line.
	Viscosity of fluid too high	Contact <i>Fristam</i> .
	Impeller clogged.	Reduce concentration of ingredients, increased pressure, contact <i>Fristam</i>
	Pump not completely filled with liquid.	Install pipe system so that pump casing is still filled with liquid when pump is at a standstill.
	Pump with geodesic suction head ¹ ; liquid level falls at standstill.	Install foot valve in suction line.
	Suction line leaky (drawing in air).	Seal suction line.
	Foot valve blocked or contaminated.	Reestablish proper function of foot valve; clean.
	Suction head too high.	Lower pump; reduce suction head.
	Air lock in suction line.	Lay suction line at steady incline.
	Excessive air or gas in pumping medium.	Install vent valve
	Cavitation at impeller inlet; resistance in suction line too high; suction head too high.	Optimize suction line; increase inlet height; lower media temperature.
	Separation of the magnetic field, magnetic coupling slipping.	Shutdown motor, remove cause of blocking, restart. Check motor startup.
Flow rate too high	Discharge-side valve opened too wide.	Throttle valve.
	Discharge line diameter too large.	Reduce nominal pipe size; insert orifice plate.
	Impeller diameter too large.	Trim impeller outside diameter. Reduce speed with frequency converter. Contact <i>Fristam</i> .
Flow rate too low; discharge head too low	Selected pump too small.	Contact <i>Fristam</i> .
	Selected impeller diameter too small.	Contact <i>Fristam</i> , replace impeller.
	Direction of rotation of motor incorrect.	Exchange connections in motor terminal box.
	Speed too low (voltage incorrect).	Correct connection according to motor rating plate.
	Nominal pipe sizes too small.	Use larger pipe diameters.
	Resistance in suction and/or pressure lines too high.	Optimize pipe system, reduce number of elbows and valves, contact <i>Fristam</i>
	Pipe clogged or full of deposits.	Clean pipes.
	Foreign objects/deposits in impeller.	Remove and clean impeller.
	Impeller incorrectly adjusted.	Check impeller clearance and re-adjust
	Density of pumping liquid too high. Viscosity of pumping liquid too high.	Contact <i>Fristam</i> .
	Separation of the magnetic field, magnetic coupling slipping.	Repair cause of the separation, restart motor, contact <i>Fristam</i> .
Metal noise	Foreign object in pump interior.	Disassemble, inspect, and repair.
	Impeller catching.	Readjust clearance; tighten impeller nut using torque wrench.
	Pump/magnetic coupling runs dry.	Immediately add pumping medium, open suction valve.
	Damaged outside magnets.	Shut down pump, check outside rotor and contaminant shell, contact <i>Fristam</i> .
	Loose screws.	Check magnetic coupling, use appropriate torque to tighten screws, replace component if necessary.

Table 10 Troubleshooting table

Problem	Possible cause	Remedy
Flow noise	Operation contrary to design in overload or part-load range.	Adjust working point to design.
	Flow loss in suction line too high.	Increase nominal sizes; shorten connection lines; prevent outgassing.
	Cavitation.	Check conditions for NPSH evaluation, contact <i>Fristam</i> .
Vibrations	Suction and discharge lines stressing pump impermissibly.	Support pipes so that pump is not stressed; possibly install vibration dampers; keep water hammers away from pump.
	Unbalance of the magnetic coupling.	Unbalance.
Motor power consumption too high	Flow rate too high.	Throttle discharge line or reduce speed with frequency converter.
	Impeller diameter too large.	Trim impeller diameter; contact <i>Fristam</i> .
	Viscosity and/or density of pumped product too high.	Contact <i>Fristam</i> .
	Massive damage to the magnetic coupling, deformation of the shaft.	Disassembly, assessment, repair by <i>Fristam</i> .
Leakage at magnetic coupling	Mechanical damage or wear of the magnetic coupling	Replace magnetic coupling including the elastomers, replace material if necessary, contact <i>Fristam</i>
	Contaminant shell defective	Contact <i>Fristam</i>
	Magnetic coupling running dry, suction height excessive, temperature of conveyed media too high	Increase the pump's supply pressure, reduce suction height, contact <i>Fristam</i>
	Pumping medium temperature too high	Contact <i>Fristam</i>
Unacceptable increase of the contamination shell's temperature	Abrasive particles in medium, viscosity of medium too high	Shut down pump, clean, and replace filter, if necessary
	Insufficient circulation, differential pressure too low	Contact <i>Fristam</i>

Table 10 Troubleshooting table

¹ The "geodesic suction head" is the vertical distance between the suction-side liquid level and the center of the impeller.

10.4 Number Key

The general list of numbers refers to the enclosed "Sectional drawings". The parts numbers comply with DIN 24250.

Part no.	Designation
101	Pump casing
160	Cover
156	Outlet side
18-1	Spherical cap bearing
18-2	Vibration damper
182	Base
212	Flange shaft
230	Impeller
341	Drive lantern
40-4	Half-length taper grooved pin
400	Flat seal
410	Profile seal
411	Gasket
412	O-ring
421	Rotary shaft seal
47-5	Ring nut
50-1	Split lock washer
50-2	V-Ring
50-3.60	Set collar
504	Spacer ring
520	Sleeve
54-3	Stationary bushing
540	Bushing
543	Spacer bush
550	Washer
551	Spacer washer

Part no.	Designation
552	Spring washer
554	Washer
561	Grooved pin
560	Pin
562	Cylindrical pin
59-4	Lantern
680	Enclosure
68-1	Support plate
68-3	Bracket for enclosure
68-4	Orifice plate
722	Flange adapter
723	Flange
724	Blind flange
800	Motor
801	Flange motor
847	Magnetic coupling
89-1	Filler piece
89-2	Spherical cap frame
89-3	Motor base
89-5	Protective cap
89-8	Flat bar steel
892	Base plate
894	Console
90-1	Stud bolt
90-3	Tapered pin
90-4	Half-length taper grooved pin

Part no.	Designation
90-5	Eye bolt
900	Screw
901	Hex cap screw
902	Threaded stud
903	Screw plug
904	Set screw
906	Impeller screw
909	Adjusting screw
91-1	Slotted cheese head screw
914	Socket screw
92-1	Star knob nut, long
92-2	Star knob nut, short
92-3	Cap nut
92-5	Forcing screw
920	Hex nut
921	Shaft nut
922	Impeller nut
93-1	Snap ring
930	Retainer
931	Retaining washer
932	Snap ring
940	Key
941	Woodruff key
950	Spring

10.5 EC Declaration of Conformity

The manufacturer: *Fristam Pumpen KG (GmbH&Co.)*
Kurt-A.-Körber-Chaussee 55
21033 Hamburg

hereby declares that the following product (pump with motor):

- Centrifugal pump models: FP, FPE, FP...V, FPH, FPEH, FPH...V, FSPE, FSP...V, FM, FZ, FC, CF, CFE, FPM, FSM
- Positive displacement pumps: FK, FKL, FL, FL2, FL3
- Powder mixers: PM
- for serial number, see cover page of operating manual

complies with all pertinent regulations of the **Machine Directive (2006/42/EC)**.

Furthermore, the machine complies with all regulations of the **"Low Voltage Directive" (2014/35/EC)**, the **"Electromagnetic Compatibility Directive" (2014/30/EG)**, Ordinance (EC) No. 1935/2004 and FDA.

The above product conforms to the following standards:

- DIN EN 809:2012-10: Pumps and pump units for liquids - Common safety requirements.
- DIN EN ISO 12100:2011-03: Safety of machinery - General principles for design - Risk assessment and risk reduction.

Documentation officer: Julia Friedsch
Tel.: +49(0)40 72556-107
Address, see address of manufacturer
Hamburg, 10/02/2020



Julia Friedsch / Head of Quality Management

Fristam Pumpen KG (GmbH & Co.)
Kurt-A.-Körber-Chaussee 55
21033 Hamburg
GERMANY

Tel.: +49 (0) 40 / 7 25 56 -0
Fax: +49 (0) 40 / 7 25 56 -166
email: info@fristam.de