



Original Instructions
Assembly Instructions

Side Channel Pump

FZ Series

Pump Type:

Pump No.:



Copyright



© Copyright 2012 Fristam Pumpen KG (GmbH & Co.)

All rights reserved. The contents, including graphic images and layout of this operating instructions manual are subject to copyright protection and to other laws for the protection of intellectual property. The publication and modification of the contents are not authorised. Moreover, you may not copy, publish and alter the contents therein for commercial purposes, or transmit the information to a third party.

The German version is the original version of the operating instructions manual.
Other languages are translations of the original operating manual.

Table of contents

1	Introduction.....	5	6.4	Pump Fixation.....	12
1.1	Foreword.....	5	6.5	Electrical Connection	13
1.2	Manufacturer	5	6.6	Connection of Sealing or Quenching Liquid (Optional).....	13
1.3	Scope of Supply	5	6.7	Cleaning.....	13
1.4	Pump Without Motor (Optional).....	5	7	Operation	14
1.5	Scope of Documentation	5	7.1	Safety Instructions.....	14
1.6	Display Conventions.....	5	7.2	Commencement of Operation	14
2	Safety Instructions	6	7.3	Monitoring of Operation	14
2.1	Basic Safety Instructions.....	6	7.4	Stopping of Operation	14
2.2	Intended Use	6	7.5	Pump Decommissioning	14
2.3	Improper Use.....	6	7.6	Cleaning in Place	15
2.4	Warning and Instruction Labels.....	6	8	Faults.....	15
2.5	Noise Emissions	7	8.1	Safety Instructions.....	15
2.6	Disposal	7	9	Maintenance	15
3	Design and Function.....	7	9.1	Safety Instructions.....	15
3.1	Principles of Design.....	7	9.2	Replacement Parts	15
3.2	Models.....	8	9.3	Inspection of Sealing and Quenching Liquid (Optional).....	16
3.3	Pump Key	9	9.4	Lubrication of Motor Bearings.....	16
3.4	Versions	9	9.5	Lubrication of Shaft Bearing.....	16
3.5	Pump Sizes	9	9.6	Motor Replacement.....	17
4	Transportation	10	9.7	Shaft Seal Replacement	18
4.1	Safety Instructions	10	9.8	Pump Head Removal.....	18
4.2	Moving With Industrial Trucks	10	9.9	Checking of the Clearances	20
4.3	Moving With Crane.....	10	9.10	Pump Head Attachment.....	20
5	Storage.....	11	9.11	Design FZ 27: Mounting and aligning the pump shaft.....	29
5.1	Safety Instructions	11	9.12	Model L: Coupling Replacement	30
5.2	Storage Conditions.....	11	10	Appendix 1.....	31
5.3	Long-Term Storage	11	10.1	Specifications.....	31
5.4	Recommissioning	11	10.2	Maintenance Intervals	31
6	Installation.....	11	10.3	Troubleshooting Table.....	32
6.1	Safety Instructions	11	10.4	Number Key.....	34
6.2	Installation Location	11	10.5	EC Declaration of Conformity	35
6.3	Reduction of Noise and Vibration.....	12	10.6	EG Declaration of Incorporation	35

11	Appendix 2 – Assembly Instructions (Optional).....	36
11.1	Safety Instructions.....	36
11.2	Scope.....	36
11.3	Moving Without Motor.....	36
11.4	Installation Location.....	37
11.5	Pump Installation.....	37

1 Introduction

1.1 Foreword

This operator's manual describes all sizes, models, and versions of the FZ pump series.

Information on the model, size, and version of your pump can be found on the rating plate on your pump and in the "Order-Related Documents" in Appendix 2.

1.2 Manufacturer

FRISTAM Pumpen KG (GmbH & Co.)

Kurt-A.-Körber-Chaussee 55

21033 Hamburg

GERMANY

Tel.: +49-40-72556-0

Fax: +49-40-72556-166

E-mail: info@fristam.de

1.3 Scope of Supply

The package includes the following items:

- Pump with motor = pump unit
 - optional: without motor
- Covers for pipe fittings
- Optional: assembly kit
- *Fristam* accessories (if applicable)
- Documentation
- ▶ Check the shipment for completeness and damage. Immediately notify *Fristam* of any missing items or damage.

1.4 Pump Without Motor (Optional)

The pump can optionally be supplied without a motor. In this case, continue reading up to and including *Chapter 3, "Design and Function," page 7*, and then skip to *Chapter 11, "Appendix 2 – Assembly Instructions (Optional)," page 36*.

1.5 Scope of Documentation

The documentation includes the following items:

- **This operator's manual**
 - Maintenance, lubrication, and tightening torque tables can be found in Appendix 1.
 - The assembly instructions for the option "Pump Without Motor" can be found in Appendix 2.

– Attached documents

- Order-Related Documents
- Supplier Documentation (motor, coupling, etc.)
- Documentation on *Fristam* accessories (if applicable)
- Certificates (materials certificates, etc.), if applicable
- Declaration of Conformity

1.6 Display Conventions

List items are preceded by dashes:

- Part 1
- Part 2

Handling instructions that must be performed in a specified order are numbered:

1. Turn device on.
2. Turn device off.

Handling instructions that do not need to be performed in a specified order are preceded by triangular bullets:

- ▶ Action
- ▶ Action

1.6.1 Safety Instructions

⚠ DANGER

A safety instruction with the signal word "Danger" indicates personal hazards causing death or serious injury.

⚠ WARNING

A safety instruction with the signal word "Warning" indicates personal hazards that may lead to death or serious injury.

⚠ CAUTION

A safety instruction with the signal word "Caution" indicates personal hazards that may lead to mild to moderate injuries.

NOTICE

A safety instruction with the signal word "Note" warns of the possibility of material damage.

2 Safety Instructions

2.1 Basic Safety Instructions

- ▶ Please read this operator's manual completely before using the pump and keep it available at the pump installation location.
- ▶ Heed the applicable national regulations of the owner's country and the company's work and safety regulations.
- ▶ All work described here may only be performed by qualified experts with caution.
- ▶ Danger of contamination: Heed legal and operational safety regulations when pumping dangerous media.

2.2 Intended Use

The standard versions of the FZ pump series are designed for use in the food industry, the pharmaceutical and biotechnology industry, and CIP process technology.

FZ pump series pumps are used for the following applications:

- Pumping of products containing gas
- Venting of suction lines
- Emptying of residues in product lines

The FZ pump series can generate discharge pressures of up to 7.0 bar. Depending on the pump size, the system pressure can reach 15 bar.

Each pump is designed according to customer requirements. The seal materials have been selected for the respective pumping conditions (medium, pressure, temperature). The pump may only be used to pump the medium it was designed for (see *Order-Related Documents* in the attached documents in *Appendix 2*).

2.3 Improper Use

The standard FZ pump series versions may not be used in explosive atmospheres. Special explosion-proof versions are available for this.

Pumping of media other than those specified can destroy the pump.

Standard pump units from *Fristam* are described in this operator's manual. If nonstandard items or extras are installed, the operator assumes the responsibility for operation.

Modifications and changes to the pump are only permissible with the explicit consent of *Fristam*.

2.4 Warning and Instruction Labels

- ▶ Do not alter or remove the labels on the pump.
- ▶ Immediately replace damaged or lost labels with ones that are true to the originals.

2.4.1 Hot Surface



Fig. 1 Safety label: "Hot Surface"

This label indicates that parts can become hot during operation or, if applicable, that hot media is being pumped. Only touch the pump if you are wearing suitable gloves.

2.4.2 No Dry Running

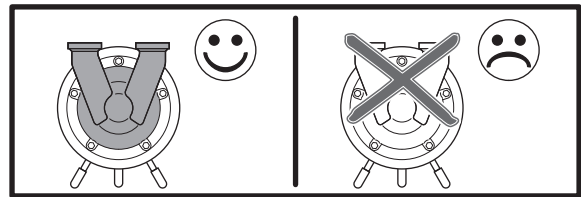

Fig. 2 Safety label: "No Dry Running"

This label indicates that the pump cannot be run dry. There must always be medium in the suction line and the pump when the pump is started. Otherwise, the pump will be damaged.

2.4.3 Direction of Rotation



Fig. 3 "Impeller Direction of Rotation" label

This label shows the direction of rotation of the impeller. It is located at the front on the pump cover.

Fristam can provide operation independent of the direction of rotation for special versions.

2.4.4 Rating Plate

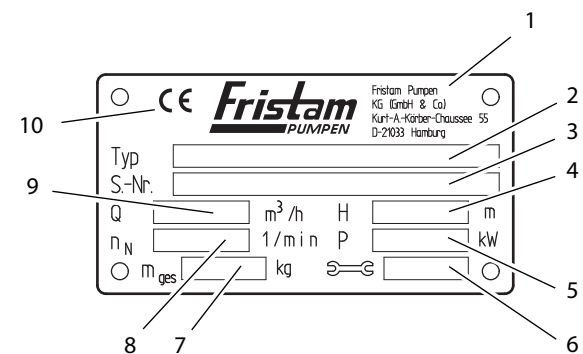

Fig. 4 Pump unit rating plate

1	Manufacturer
2	Typ: pump series, pump size, model, version
3	S.-Nr.: serial number of the pump
4	H: discharge head [m]
5	P: motor output [kW]
6	Year of manufacture
7	mttl: mass (total) [kg]

8	n_R : rated speed [1/min]
9	Q: flow rate [m ³ /h]
10	CE mark

2.5 Noise Emissions

- ▶ The local noise exposure regulations must be complied with. For noise emission values for the pumps, please see *Chapter 10.1, "Specifications," page 31.*

⚠ CAUTION

Noise Generated by Running Pump

Hearing damage.

- ▶ Wear ear protectors when using pumps with specified sound pressure levels of greater than 80 dBA.

2.6 Disposal

2.6.1 Disposal of Transportation Package

- ▶ Recycle the transportation package.

2.6.2 Models K, KF, and L 1: Disposal of Grease

- ▶ Dispose of grease and objects saturated with grease in an environmentally friendly manner in accordance with applicable regulations.

2.6.3 Model L 2: Disposal of Lubricating Oil

- ▶ Dispose of oil and objects saturated with oil in an environmentally friendly manner in accordance with applicable regulations.

2.6.4 Disposal of Pump

- Carefully clean the pump. Dispose of residues in an environmentally friendly manner in accordance with applicable regulations.
- Dismantle the pump into its constituent parts.
- Dispose of the pump parts in an environmentally friendly manner in accordance with applicable regulations.

2.6.5 Disposal of Electrical and Electronic Scrap

- ▶ Dispose of electrical and electronic scrap in accordance with applicable directives.

3 Design and Function

3.1 Principles of Design

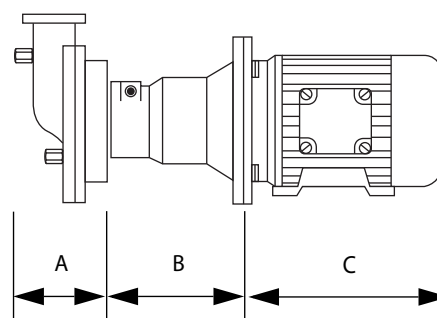

Fig. 5 Principles of design of pumps illustrated using the K model

A	Pump head
B	Lantern
C	Electric motor

3.1.1 Pump Head (A)

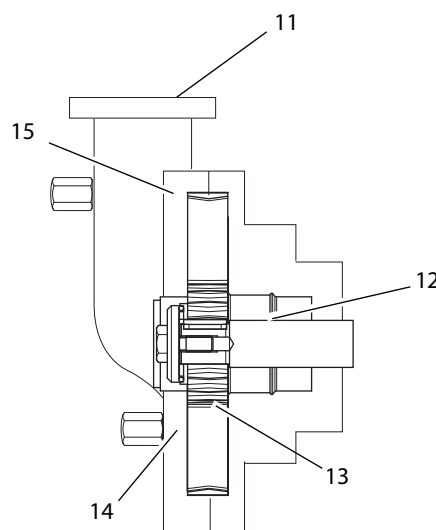

Fig. 6 Pump head

11	Suction/discharge line connection
12	Shaft seal
13	Impeller
14	Pump cover
15	Pump casing

Shaft Seal (12)

Two seal types are available for use:

- Single shaft seal
- Double shaft seal

With the double shaft seal, there are two additional connections for the sealing liquid on the pump casing. These connections are not shown in the figures in this operator's manual.

Impeller (13)

Open impellers with radial blades are standardly used in the FZ pump series.

Pump Cover (14)

The connections for the suction and discharge lines are located on the pump cover.

Pump Casing (15)

The impeller and the shaft seal are built into the pump casing.

3.1.2 Lantern (B) and Electric Motor (C)

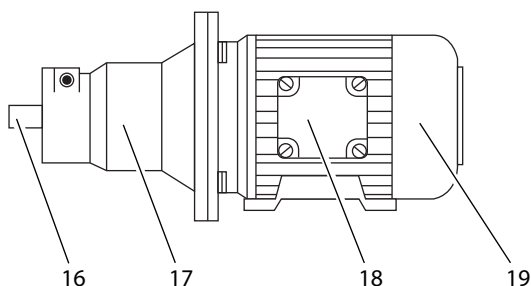

Fig. 7 Lantern and electric motor

16	Pump shaft
17	Lantern
18	Electrical connection
19	Electric motor

Lantern (16)

The lantern is present in all models except the special motor. The lantern connects the pump casing to the motor. Two different versions are possible, depending on pump size:

- The pump casing is screwed to the lantern via a flange connection.
- The pump casing is inserted into the lantern and mounted with a clamp.

Models with lanterns:

- FZP
- K

Compact bearing support. An additional bearing for the pump shaft is located inside the lantern.

- KF

Compact bearing support with base. An additional bearing for the pump shaft is located inside the lantern with base.

- L

Bearing block. An additional bearing for the pump shaft is located inside the lantern with base. The pump shaft is connected to the motor via a coupling.

Electric Motor (19)

The following motor types can be mounted:

- IEC standard motor with drive side fixed bearing (A side), feather key and shaft pin of the following types:
 - IM B3: motor model with base
 - IM B5: motor model with flange
 - IM B3/B5: motor model with flange and base

Various mounting types are possible for the IEC standard motor:

- A *Fristam* pump shaft is clamped to the motor shaft pin.
 - The motor is fastened to the flange on the compact bearing support (with base).
 - The motor is connected to the bearing block via a coupling.
 - Special motor with *Fristam* pump shaft
- With the special motor, the *Fristam* pump shaft is already integrated and connected permanently to the motor.

3.2 Models

The model is indicated on the rating plate. See Chapter 2.4, "Warning and Instruction Labels," page 6.

The following are shown as examples:

- Lantern clamp-mounted
 - Without enclosure
- See Chapter 3.4, "Versions," page 9.

3.2.1 Model FZ or FZP

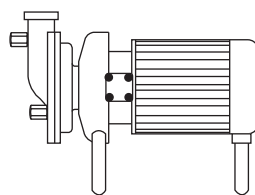

Fig. 8 Model FZ with special motor

Motor: Special motor
 Design: Without lantern

3.2.2 Model K

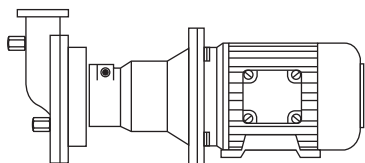

Fig. 9 Model KF

Motor: IEC standard motor, motor model B3/B5
 Design: Compact bearing support

3.2.3 Model KF

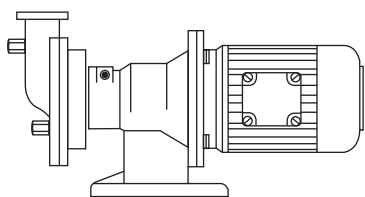

Fig. 10 Model KF

Motor: IEC standard motor, motor model B5
 Design: Compact bearing support with base

3.2.4 Model L

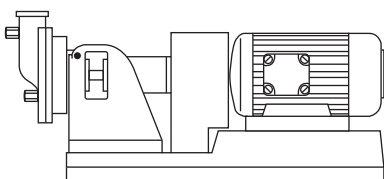

Fig. 11 Model L

Motor: IEC standard motor, motor model B3
 Design: Bearing block with coupling, coupling protection, base frame

3.2.5 Design FZ 27

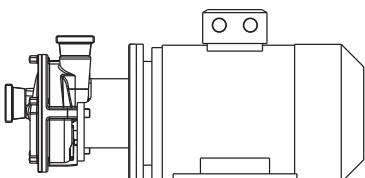

Fig. 12 Design FZ 27

Motor: IEC standard motor, model B3/B5
 Design: With lantern

3.3 Pump Key

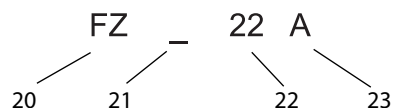

Fig. 13 Type designation example

20	Pump type
21	Supplementary character 1
22	Pump size
23	Supplementary character 2

(20) Pump Type

FZ Side channel pump

(21) Supplementary Character 1

P Sampling pump (FZ 10)

(22) Pump Size

— Sizes: see Chapter 3.5, "Pump Sizes," page 9.

(23) Supplementary Character 2

PM Powder mixer

A, B, C, D Versions; see Chapter 3.4, "Versions," page 9:

K Compact bearing support

KF Compact bearing support with base

L1, L2 Bearing block with coupling

H Pump casing with heating jacket

h Pump cover with heating jacket

3.4 Versions

Version	Enclosure	Spherical Cap Legs	Motor Foot
A	With	With	Without
B	Without	Without	With
C	Without	With	Without
D	With	Without	With

Table 1 Versions

3.5 Pump Sizes

Pump Sizes
10
15
17
20

Table 2 Pump sizes

Pump Sizes

22
25
27

Table 2 Pump sizes

Note: If the (optional) pump without motor is supplied, please first read Chapter 11, "Appendix 2 – Assembly Instructions (Optional)," page 36.

4 Transportation

Transportation may only be performed by trained personnel. The pump can be moved using an industrial truck or a crane. Always move the pump in the installation condition.

4.1 Safety Instructions

- ▶ Danger of injury from falling or unsecured parts.
 - Only use suitable means of conveyance and hoists. Information on pump weight can be found on the pump's rating plate as well as in the *Order-Related Documents in Appendix 2*.
 - Before moving the pump secure it to prevent it from tipping over. Secure the pump to the pallet with tie-down straps, or screw the pump to the pallet.
 - Do not leave the pump in a raised position for longer than necessary.
- ▶ Damage to pump by contamination, impact, or moisture.
 - Remove the pipe fitting covers just prior to connection to the pipes.

4.2 Moving With Industrial Trucks

Preparation

- ▶ Ensure that the pump is adequately secured to the pallet.

Procedure

1. Pick up the pallet with the forks on the industrial truck.
2. Carefully move the pallet to the designated location and set down.

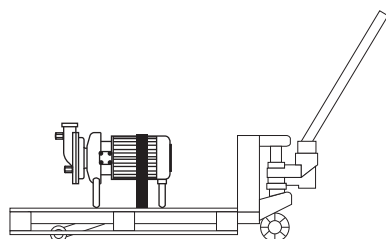

Fig. 14 Moving with industrial truck

4.3 Moving With Crane

⚠ WARNING

Falling Parts

Death from crushing, pinching of extremities, material damage.

- ▶ Do not lift the pump at the eyebolts on the motor and pump casing to move because these eyebolts are not designed for the total weight.
- ▶ Only use hoists that are designed for the total weight of the pump.
- ▶ Ensure that the area below the pump is clear of people.

⚠ WARNING

Swinging Parts

Crushing and serious injuries.

- ▶ Start and stop the crane with pump smoothly.
- ▶ Ensure that the danger zone of the pump is clear of people.

Auxiliary Equipment

Hoists: round slings tested in accordance with DIN EN 1492-1 and 1492-2

Preparation

- ▶ Remove load-securing devices.

Procedure

1. Wrap the round sling twice around the back end of the motor. Do not lay over the fan shroud (see Fig. 15, "Moving with crane," page 11).
2. Lay the other end of the round sling between the lantern and the pump casing. Do not lay the round sling over any sharp edges or corners.
3. Guide both loops to the crane hook and rotate by 180° to ensure that the belt will not slip on the hook.
4. For double shaft seal:
 - Note:** Round sling compresses sealing water tubes. Material damage to double shaft seal.
 - ▶ Do not lay the round sling on the sealing water tubes.
5. Position the center of gravity to ensure that the pump is lifted horizontally.
6. Lift the pump.

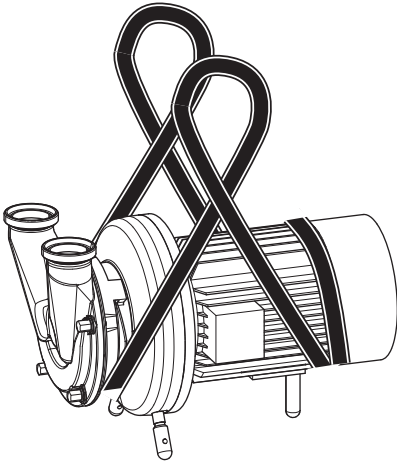

Fig. 15 Moving with crane

5 Storage

5.1 Safety Instructions

- ▶ Corrosion: Condensation can build up under a tarp and destroy the pump. Ensure adequate ventilation.

5.2 Storage Conditions

- ▶ Store the pump as follows:
 - Dry, in low humidity
 - Protected against frost and heat, optimally at a temperature of +20°C to +25°C
 - Ventilated
 - Dust-free

5.3 Long-Term Storage

For a storage time of longer than six months, heed the following:

- ▶ The shaft seals must be specially treated before long-term storage:
 - **For single shaft seal**
The impeller nut must be loosened so that the seal can relax and the sliding surfaces do not stick together.
 - **For double shaft seal**
Remove the complete shaft seal and store separately to prevent the sliding surfaces from sticking together.

Information on the shaft seal can be found in the *Order-Related Documents* in *Appendix 2*.

- ▶ All movable pump parts must be rotated every three months.

5.3.1 Storage of Elastomers

Storage Conditions

- Storage temperature between +5°C and +20°C
- Relative air humidity below 70%
- No direct sunlight
- Deformation-free storage

5.4 Recommissioning

- ▶ After long-term storage and before commissioning, check seals, bearings, and lubrication.

6 Installation

6.1 Safety Instructions

- ▶ Danger of injury from falling parts.
 - Wear safety shoes.
 - Check load capacity and attachment of hoists.
- ▶ Danger of injury from unstable assembly.
 - Tighten screws to the specified tightening torque (see *Chapter 10.1.1, "Tightening Torques for Screws and Nuts," page 31*).
 - Use a torque wrench or an impact driver with adjustable torque.
- ▶ Material damage from swinging during adjustment of spherical cap feet.
 - Use spherical cap base plates.

6.2 Installation Location

For standard pumps, the installation location must meet the following requirements:

- Nonexplosive atmosphere
- Dust-free environment
- Ambient temperature: –20°C to +40°C
- Moisture and salt contents in ambient air:
The values are given in the motor supplier documentation. It can be found in the attached documents (*Appendix 2*).
- Foundation sized adequately for the pump weight
- Horizontal and level installation surface, adequate installation surface strength for pump mass
- Adequate clearance for maintenance work
- Adequate air supply for motor cooling

6.3 Reduction of Noise and Vibration

6.3.1 Primary Measures

- ▶ Operate the pump in the optimum working range.

Note: Pump must not be blocked during operation. Pump may only be throttled to the minimum allowable flow rate; see "Performance Chart."

- ▶ Decouple the suction and discharge lines from vibrations.
 - Support lines.
 - Align lines.
 - Install vibration isolators.

6.3.2 Secondary Measures

- ▶ Take structural measures such as the following:
 - Acoustic paneling
 - Enclosure in housing

6.4 Pump Fixation

Models FZ/K/FZP

- ▶ Versions A and C:
Set up the pump on the spherical cap bearings and align.
- ▶ Versions B and D:
Screw the pump on the motor foot to the foundation.

Model KF

- ▶ Versions A and C:
Set up the pump on the spherical cap bearings and align.
- ▶ Versions B and D:
Screw the pump on the compact bearing support with base to the foundation.

Model L

- ▶ Versions A and C:
Set up the pump on base frame on the spherical cap bearings and align.
- ▶ Versions B and D:
Screw the pump on the base frame to the foundation.

Design FZ 27

- ▶ Versions A and C:
Install and align the pump on the spherical cap bearings.
- ▶ Versions B and D:
Screw the pump on the pump base to the foundation.

Carriage (Optional)

1. Set up the pump at the installation location. Lock the locks on the rollers (if present) or secure the carriage with chocks.
2. Ground the carriage to dissipate electrostatic charge.
3. Position hose line to ensure that it cannot be damaged.

6.4.1 Installation of Pipes

- ▶ Lay and connect pipes as follows:

- Keep the pipe resistance as low as possible: Avoid unnecessary installation of valves, elbows, and abrupt pipe transitions.

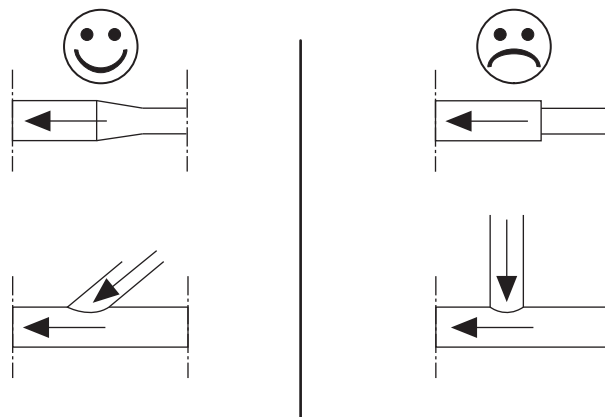

Fig. 16 Pipe transitions

- Design pipe cross section so that no unnecessary pressure losses or cavitation occurs in the suction area. Verify this in the project planning stage.
- Install the suction lines in horizontal position or at a constant dropping angle towards the pump unit. Rule out the possibility of air pockets and dips in the pipes.

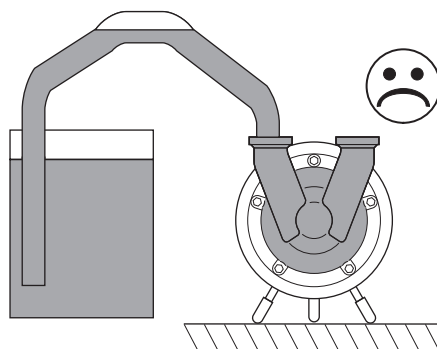

Fig. 17 Air pocket in pipe

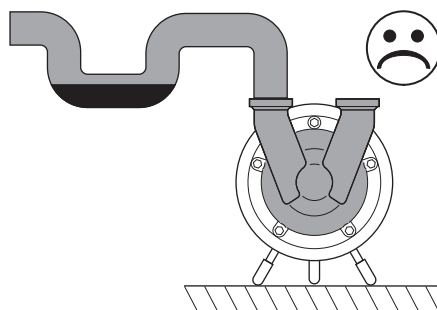

Fig. 18 Dip in pipe

- Pipe bends upstream of suction connection: Heed minimum clearance and minimum bend radius:

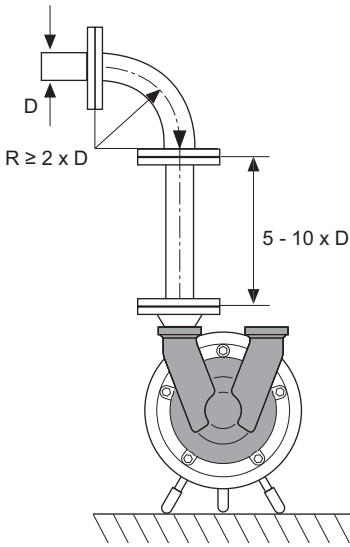

Fig. 19 Laying of the suction line

- Connect the pipes to the pump so that they are free of tension and compression to ensure that no stresses are applied to the pump.
- Secure pipes to ceilings, walls, or floor using pipe clamps.
- Align pipes flush with pump connections using a bracket.

6.5 Electrical Connection

⚠ WARNING

Electrostatic Charge Buildup

Electric shock.

- ▶ Ground pipes and pump to dissipate electric charge.

Electrical connection may only be performed by a qualified electrician.

1. Heed the connection values on the motor's rating plate. The specified voltage must not be exceeded.
2. Connect the motor according to the circuit diagram in the terminal box of the motor.
3. Protect cable feedthroughs against penetration by moisture.

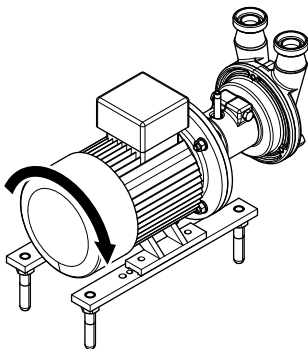

Fig. 20 Direction of rotation of motor fan wheel

4. Turn on the motor for 2 to 3 seconds. Compare the direction of rotation of the motor fan wheel against the direction indicated by the arrow (if available) on the pump head.
5. Reverse the polarity if the pumping direction is incorrect.

6.6 Connection of Sealing or Quenching Liquid (Optional)

In versions with double shaft seal, the seal chamber must be flushed with a sealing or quenching liquid.

- ▶ Use a suitable medium as a sealing or quenching liquid.
 - To be suitable, the medium must fulfill the following conditions:
 - It must be clean and have good lubricating properties.
 - It must be compatible with the product to be pumped.
 - It must not be easily vaporized during operation.

6.6.1 Installing the pipelines

1. Install and seal the supplied flushing tubes.
2. As a standard, the feed line should be fitted at the **bottom** of the shaft seal.
3. As a standard, the return line should be fitted at the **top** of the shaft seal.

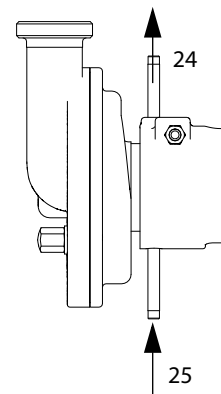

Fig. 21 Installing the pipelines

24	Return line
25	Inlet

4. Install the following valves into the pipelines:
 - Install the sight glass in the return line.

6.7 Cleaning

Only use cleaning agents that comply with the hygiene guidelines for the respective pumping medium.

1. Before sealing the pump ensure that there are no foreign objects inside the pump or pipes.
2. Seal the pump.
3. Connect the pipes.

4. Thoroughly clean the pump and the pipe system before initial use.

7 Operation

7.1 Safety Instructions

- ▶ **Danger of burning:** Pumping of hot media can cause the pump to become very hot. Check the temperature before touching the pump.
- ▶ **Noise emissions:** The A-weighted sound pressure level of the pumps can be greater than 80 dBA. Always wear ear protectors in the vicinity of the running pump.
- ▶ **Danger of bursting:** If the allowable pressure and temperature ranges are exceeded, the pump may burst or become leaky. The pressure and temperature ranges for the pump must be complied with (see *Order-Related Documents in Appendix 2*).
- ▶ **Danger of bursting:** Cold extinguishing agents used to extinguish a pump fire can cause the hot pump to burst. Do not cool the pump down excessively when extinguishing the fire.
- ▶ **Pump running in reverse direction despite emergency shut-off:** If the pump is shut off using the emergency shut-off function, it will run in reverse direction due to the pumping medium in the discharge line. Install a check valve in the discharge line.
- ▶ **Destruction of shaft seal when pump runs in reverse direction.** Reverse running destroys the springs in the shaft seal. Always operate the pump in the direction of rotation. See *Chapter 2.4.3, "Direction of Rotation," page 6*.

7.2 Commencement of Operation

NOTICE

Damage to Shaft Seals

If the pump runs without a pumping medium, the mechanical seal will be damaged.

- ▶ Ensure that the pumping medium always reaches the upper edge of the outlet side when turning pump on.

NOTICE

Damage to Double Shaft Seals

If the pump runs without a sealing medium, the shaft seal will be damaged.

Ensure that during operation:

- ▶ The sealing liquid flows with the necessary pressure through the double shaft seal.

The prescribed sealing fluid pressure is specified in the "Order-related documents" in the sectional drawing of the shaft

seal. The "Order-related documents" are included in this operating manual.

- Negative pressure in the seal chamber is not allowed.

If no pressure is noted in the "Sectional drawing of the shaft seal", the following applies:

- A max. pressure of 0.2 bar is allowed for seals to which sealing fluid is applied without pressure or which are flushed.

- ▶ The temperature of the sealing liquid is maintained at $T < 70\text{ }^{\circ}\text{C}$.

1. Open the valve in the suction line.
2. Open the valve in the discharge line.
3. Completely fill the pump and suction line with pumping medium. Allow any air pockets that are present to escape.
4. Turn on the motor. The pump now pumps against the opened valve in the discharge line. This will limit the starting current.
5. Slowly close the valve in the discharge line and adjust to the working point.

7.3 Monitoring of Operation

During operation heed the following points:

- **Damage to shaft seal:** Regulation of the pump output via the suction-side valve can lead to damage of the pump and the shaft seals. Regulate the pump output only by means of the discharge-side valve.
- **Damage to pumping medium:** If during operation the valve in the discharge line is closed abruptly or for a long period of time, water hammers can occur in the pump and lead to damage to the pump and/or the pumping medium.
- **Damage to pump:** Exceeding of the output can lead to damage of the pump and the shaft seals. Do not exceed the maximum speed of 1,750 rpm.
- **Damage to motor during operation with frequency converter:** If the speed is too low, the motor will overheat. Please refer to the motor supplier documentation in the attached documents.

7.4 Stopping of Operation

1. Turn off the motor.
2. Close the valve in the suction line to prevent dry running of the pump.
3. Open the valve in the discharge line.

7.5 Pump Decommissioning

1. Turn off the motor.
2. Close the valve in the suction line.
3. Close the valve in the discharge line.

4. De-energize the pump.
5. Empty the pump.
6. Clean the pump; see *Chapter 6.7, "Cleaning," page 13*.
7. Dry the pump.
8. Protect the interior of the pump from moisture, e.g., with silica gel.
9. Seal the pipe connections with caps to prevent penetration of dirt and foreign objects.
10. Please see *Chapter 5, "Storage," page 11* for additional steps.

7.6 Cleaning in Place

7.6.1 CIP Process

The FZ series pumps are suitable for the CIP (Cleaning In Place) process. The following guidelines apply to the CIP process:

Example of a Cleaning Cycle

1. Perform preliminary flush with water.
2. Perform caustic flush with lye (NaOH; see *Table 3, "CIP cleaning"*).
3. Perform intermediate flush with water.
4. Perform acid flush with nitric acid (HNO₃; see *Table 3, "CIP cleaning"*).
5. Flush with water.

Medium	Process Temperature [°C]
NaOH (approx. 1%–2%)	80–85
HNO ₃ (approx. 1%)	60–65

Table 3 CIP cleaning

During cleaning a sufficiently high flow rate must be achieved. The prerequisites for this are as follows:

- Pump differential pressure of 2–3 bar
- Sufficiently high discharge rate obtained through appropriate pump size and pipe cross sections

If values deviate from these specifications, please contact *Fristam*.

7.6.2 SIP Process

The FZ pump series can only be used with the SIP (Sterilization In Place) process with the prior approval of *Fristam*.

Suitability depends on the selected elastomers.

The maximum process temperature is 145°C.

In ATEX operation, temperatures might deviate, see supplementary ATEX manual, "*Temperature limits*".

8 Faults

For information on faults, possible causes, and remedies, please see *Chapter 10.3, "Troubleshooting Table," page 32*.

8.1 Safety Instructions

- ▶ Danger of burning: Pumping of hot media can cause the pump to become very hot. Check the temperature before touching the pump.
- ▶ Pump running in reverse direction despite emergency shut-off: If the pump is shut off using the emergency shut-off function, it can continue to run in reverse direction due to the pumping medium in the discharge line. Install a check valve.

9 Maintenance

For information on maintenance intervals, please see *Chapter 10.2, "Maintenance Intervals," page 31*.

9.1 Safety Instructions

- ▶ Rotating parts: Danger of injury. Before removing the coupling guard and guard plate, turn off the pump motor and prevent it from being able to be turned on accidentally.
- ▶ Danger of burning: Pumping of hot media can cause the pump to become very hot. Check the temperature before touching the pump.
- ▶ Electric shock: Liquids flowing through the system result in buildup of electrostatic charge. Ground the pipes and the pump.
- ▶ Uncontrolled outflow of liquids: Before maintenance or adjustment of the pump:
 - Close the suction and discharge valves in front of and behind the pump.
 - Block off the sealing or quenching liquid line.
- ▶ Leaking liquids: Acid burns and contamination. Before opening the pump completely empty the pump casing.
- ▶ Tension cracks: Do not rapidly cool the pump.
- ▶ Material damage from scratching of polished surfaces. For a polished surface, use a copper socket wrench socket.

9.2 Replacement Parts

- ▶ Use of replacement parts that are not approved by *Fristam* can lead to serious personal injury and material damage. If you have any questions regarding approved replacement parts, please contact *Fristam*.

- ▶ *Fristam* registers all shipped pumps. For ordering replacement parts from *Fristam*, you require the following information:

Serial number: see

- rating plate or
- number stamped into pump casing.

9.3 Inspection of Sealing and Quenching Liquid (Optional)

For pumps equipped for "locking system" or "quenching system," the sealing liquid head must be checked daily.

- ▶ Check the sealing liquid head and compare with the specified value.

The specified value can be found in the *Order-Related Documents* on the "Sectional Drawing" of the shaft seal. The *Order-Related Documents* are attached to this operator's manual in *Appendix 2*.

- ▶ The sealing liquid is heated by hot pumping medium and by operation of the pump.

Ensure that the temperature of the sealing medium is sufficiently lower than the evaporation point during operation.

9.4 Lubrication of Motor Bearings

- ▶ Lubricate the motor bearings in accordance with the motor manufacturer's specifications (see "*Motor Supplier Documentation*").

9.5 Lubrication of Shaft Bearing

The pump models FZ and FZP with special motor do not have additional shaft bearings, and therefore must not be lubricated.

9.5.1 Model L 2

For model L 2, the oil must be changed at regular intervals.

1. Turn on the motor and let it run until the normal operating temperature is reached.
2. Turn off the motor and prevent it from being able to be turned on accidentally.
3. Place a suitable oil collection container under the oil drain plug.
4. **Caution!** Danger of burning from hot oil.
 - ▶ Wear suitable protective gloves.
 - ▶ Loosen and remove the oil drain plug.
5. Drain the oil completely and dispose of oil in accordance with local regulations.
6. Clean and remount the oil drain plug and seal.
7. Fill with new oil. We recommended using the: SAE 15W40 oil type. Alternatively, use an equivalent brand of lubricant of similar quality and viscosity.

Oil volume = 1 liter

9.5.2 Model L1

- ▶ Do not relubricate the deep groove ball bearing, but replace it completely.
- At constant operating conditions, the raising of power consumption, noise level or vibration indicates that wear has occurred. Replace the deep groove ball bearing consequently.

Prerequisites

- Pump head has been removed.
- Motor with coupling has been removed.

Procedure

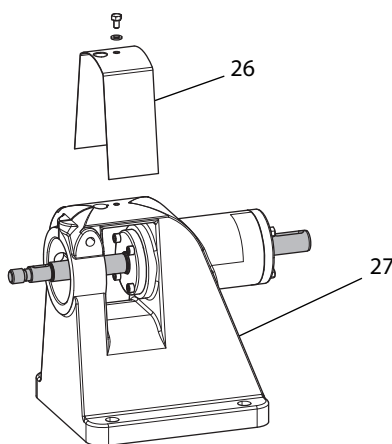

Fig. 22 Bearing block cover

1. Take the cover (26) off of the bearing block (27).

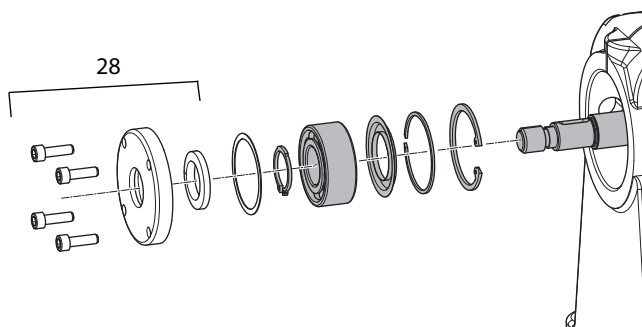

Fig. 23 Model L1, pump shaft, pump-side

2. Remove the bearing cap (28) on the pump side.

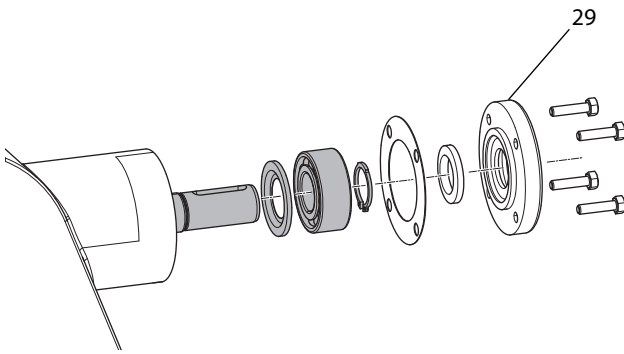

Fig. 24 Model L1, pump shaft, motor-side

3. Remove the bearing cap (29) on the motor side.
4. Force out the shaft in the direction of the pump head.
Note: All parts that are gray in the above two figures remain on the shaft.
5. Clean the surfaces of all parts and check for damage. Replace if necessary.
6. Relubricate the angular contact ball bearing. We recommend using: JAX Halo-Guard FG-2 bearing grease or alternatively a white NSF H1 grease. Alternatively, use an equivalent brand of lubricant of similar quality and viscosity.
Bearing grease amount = 10 g
7. Press the pump shaft with the bearing into the bearing block.
8. Mount the bearing cap on the motor side.
9. Mount the bearing cap on the pump side.
10. Mount the cover (26).

9.5.3 Models K and KF

- ▶ Do not relubricate the deep groove ball bearing, but replace it completely.
- At constant operating conditions, the raising of power consumption, noise level or vibration indicates that wear has occurred. Replace the deep groove ball bearing consequently.
- ▶ Grease the cylindrical roller bearing with bearing grease.

Model	Bearing Grease Amount
K1 and KF 1	20 g
K2 and KF 2	40 g
K3 and KF 3	60 g

Table 4 Bearing grease amounts: model KF

Prerequisites

- Pump head has been removed.
- Motor has been removed.

Procedure

1. Remove the bearing cap (32).

2. Force out the pump shaft (30) with the bearing toward the motor side.

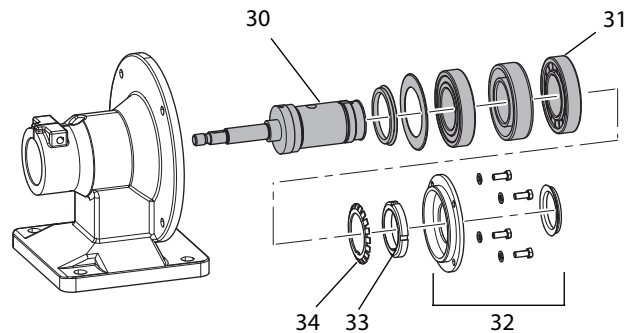

Fig. 25 Model KF, shaft bearing

3. Remove the bearing nut (33) and the guard plate (34).
4. Remove the outer race of the cylindrical roller bearing.
Note: All parts that are gray in the above figure remain on the shaft.
5. Clean the surfaces of all parts and check for damage. Replace if necessary.
6. Relubricate the cylindrical roller bearing (31). We recommend using: JAX Halo-Guard FG-2 bearing grease or alternatively a white NSF H1 grease. Alternatively, use an equivalent brand of lubricant of similar quality and viscosity. See Table 4, "Bearing grease amounts: model KF".
7. Put the outer race back onto the shaft.
8. Place the guard plate and the bearing nut on the shaft, and tighten the bearing nut.
9. Press the pump shaft with the bearing back into the lantern.
10. Mount the bearing cap (32).
11. Remount the cover (26) on the bearing block (27); see Fig. 22, "Bearing block cover," page 16.

9.5.4 Design FZ 27

The model FZ27 has no additional shaft bearing and therefore needs no lubrication.

9.6 Motor Replacement

Special Motor

1. Turn off the motor and prevent it from being able to be turned on accidentally.
2. Remove the pump head (see Chapter 9.8, "Pump Head Removal," page 18).
3. Replace the special motor.
4. Replace the mechanical seal if necessary, and mount the pump head (see Chapter 9.10, "Pump Head Attachment," page 20).

IEC Standard Motor for Models K and KF

1. Turn off the motor and prevent it from being able to be turned on accidentally.
2. Take the motor off of the compact bearing support or the compact bearing support with base.
3. Dispose of the motor in an environmentally friendly manner. See Chapter 2.6.5, "Disposal of Electrical and Electronic Scrap," page 7.
4. Insert the key of the old motor into the new motor.
5. Screw the motor to the compact bearing support or the compact bearing support with base.

IEC Standard Motor for Model L

1. Turn off the motor and prevent it from being able to be turned on accidentally.
2. Remove the coupling guard.
3. Detach the motor from the base frame or the foundation.
4. Take the coupling parts off of the motor.
5. Dispose of the motor in an environmentally friendly manner. See Chapter 2.6.5, "Disposal of Electrical and Electronic Scrap," page 7.
6. Mount the coupling parts onto the replacement motor (proceed as described in Chapter 9.11, "Design FZ 27: Mounting and aligning the pump shaft," page 29 to replace the coupling).
7. Place the replacement motor on the base frame or the foundation.
8. Check the parallel and angular misalignment of the shafts.

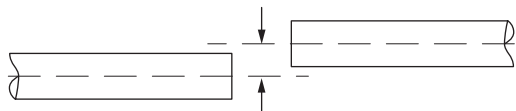

Fig. 26 Parallel misalignment

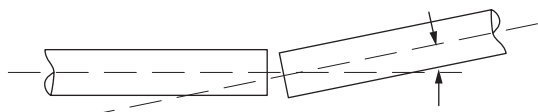

Fig. 27 Angular misalignment

9. Minimize deviations from the angular and parallel misalignment. Realign the shafts if necessary.
10. Screw the motor to the base frame or the foundation.
11. Mount the coupling guard.

IEC standard motor in model FZ 27

1. Switch off the motor and prevent it from being restarted.
2. Remove the pump head, (see Chapter 9.8, "Pump Head Removal," page 18).
3. Remove lantern from motor.
4. Remove the shaft.
5. Replace the motor.

6. Mount the shaft and align (see Chapter 9.11, "Design FZ 27: Mounting and aligning the pump shaft," page 29).
7. Mount the lantern.
8. Check the clearance (see Chapter 9.9, "Checking of the Clearances," page 20).
9. If required, replace the mechanical seal and mount the pump head, (see Chapter 9.10, "Pump Head Attachment," page 20).

9.7 Shaft Seal Replacement

The shaft seal must be replaced if:

- Pumping medium or sealing or quenching liquid flows out of the pump on the atmosphere side.
- Sealing liquid leaks into the pumping medium.

Procedure

1. Remove the pump head (see Chapter 9.8, "Pump Head Removal," page 18).
2. Replace the mechanical seal, and mount the pump head (see Chapter 9.10, "Pump Head Attachment," page 20). Perform the following tasks according to the given shaft seal:
 - ▶ Preassemble the seals on the shaft.
 - ▶ Preassemble the pump casing.
 - ▶ Mount the pump casing on the lantern.
 - ▶ Mount the mechanical seal.
 - ▶ Mount the impeller.
 - ▶ Screw on the pump cover.

9.8 Pump Head Removal

9.8.1 Preparation

1. Turn off the motor and prevent it from being able to be turned on accidentally.
2. Close the valve in the discharge line.

3. Close the valve in the suction line.
4. Completely empty the pump.

9.8.2 Procedure

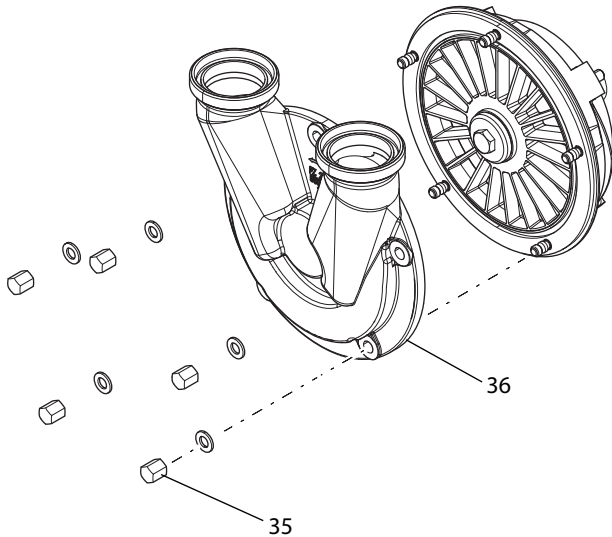

Fig. 28 Pump cover

1. Loosen the nuts (35) on the pump cover.
2. Remove the nuts, the washers, the pump cover (36), and the cover seal.

WARNING: Risk of injury when stopping the impeller by hand.

- ▶ Block the impeller (40) with a special tool.

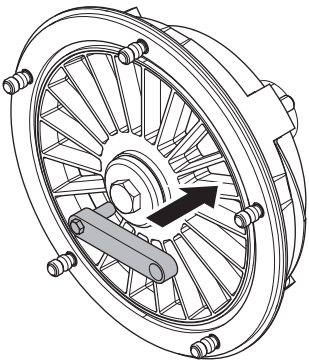

Fig. 29 Mounting the special tool

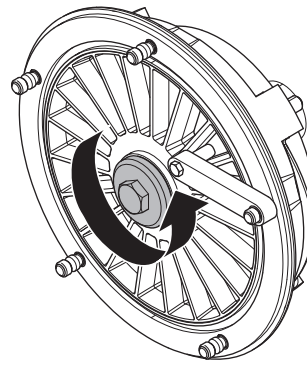

Fig. 30 Loosening the blocked impeller nut

3. Loosen the impeller fastener (37), and remove with the O-ring (38).

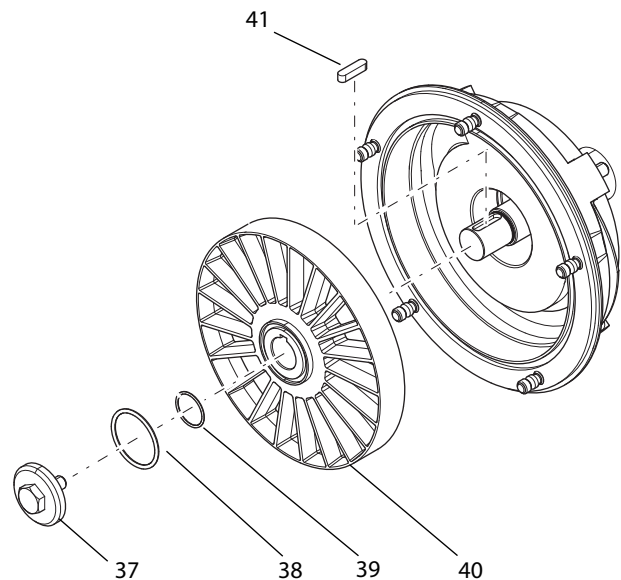

Fig. 31 Impeller

4. Take the snap ring (39), the impeller (40), and the key (41) off of the shaft.
5. Only for pumps with double shaft seals: Remove the flushing tubes for sealing or quenching liquid.
6. Pull the pump head with the pump-side shaft seal off of the shaft as follows:
 - 6a. Clamp connection variant
 1. Loosen the clamp bolt.
 2. Slightly spread the clamp connection with a wedge.
 3. Pull the pump casing out of the clamp connection.
 - 6b. Flange connection variant
 1. For models K3 and KF3:
Remove the cover plates on the compact bearing support.
 2. Loosen the fastening screws on the flange and remove.
 3. Remove the pump casing.
7. Take the shaft seal out of the pump casing.

9.9 Checking of the Clearances

The position of the impeller is determined by the position on the shaft.

The clearances are set through the position of the pump casing with respect to that of the impeller.

Prerequisites

- Pump casing is connected firmly to the lantern.
- Pump cover has been removed.
- The impeller has been mounted and the impeller nut tightened.

9.9.1 Measurement of the Impeller–Casing Clearance

1. Measure the clearance between the impeller and the casing using a leaf feeler gauge (Fig. 32, "Impeller–casing clearance").
2. Compare the clearance with Table 5, "Clearances".

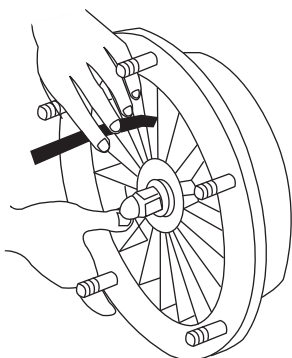

Fig. 32 Impeller–casing clearance

Pump Size	Impeller–Casing Clearance [mm]
FZP 10	0.3
FZ 15	0.15–0.2
FZ 17	0.15–0.2
FZ 20	0.25–0.3
FZ 22	0.35–0.4
FZ 25	0.45–0.5
FZ 27	0.45 - 0.5

Table 5 Clearances

9.10 Pump Head Attachment

The pump assembly is dependent on the respective pump size and model as well as the respective shaft seal (see *Order-Related Documents* in Appendix 2).

NOTICE

Incorrect Elastomers

Pump leakiness.

- ▶ Ensure that the elastomers are appropriate for the condition of the pumping medium. Please refer to the *Order-Related Documents*.

Preparation

- ▶ Clean all pump parts and check for damage and accuracy of fit.
- ▶ If necessary, rework or replace pump parts.
- ▶ Assemble in clean conditions, carefully, and using little force. The seals could be permanently deformed or break in part.
- ▶ Replace all O-rings.
- ▶ To reduce friction, wet the O-rings and the sliding faces with water, alcohol, or silicone grease.
- ▶ Clean the sealing surfaces of the mechanical seals with a degreaser, e.g., OKS 2610 Universal Cleaner. Do not allow the sealing surfaces to come into contact with oil or grease and do not touch with your fingers afterwards.

Tip: The joint retaining compound "Euro Lock A64.80," e.g., is suitable for gluing in bearings and bushings.

Tip: The screw retaining compound "Euro Lock A24.10," e.g., is suitable for gluing in set screws.

9.10.1 Clearance Setting for Flange Connection

Note: For pumps with flange connections, the clearance is set using shims. To determine the exact number and thicknesses of shims needed, first mount the impeller nut, the impeller, and the key as follows and then remove again.

1. Slide the pump casing (42) and the shims (43) over the shaft to the flange (44) and screw on.

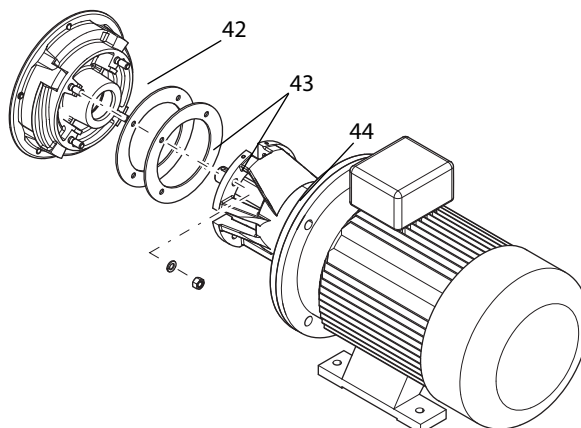

Fig. 33 Setting the clearance for the flange connection

2. Slide the seal driver onto the shaft.
3. Slide the key and the impeller onto the shaft.
4. Tighten the impeller fastener.
5. Check the clearances; see *Chapter 9.9, "Checking of the Clearances," page 20.*
6. Remove the impeller fastener, the impeller, and the key.
7. Remove the pump casing.
8. If the clearance is incorrect:
 - ▶ Adjust the clearance using the appropriate shims.

9.10.2 Mounting Seals

For details regarding the shaft seal installed in the pump, see "Sectional Drawing of Shaft Seal" in the "Order-Related Documents" and "Spare Parts List".

The part numbers in this chapter correspond to DIN 24250.

The section below describes the installation of standard shaft seals for applications A to J. The actual design might deviate slightly from that described here, depending on the ordered model.

If you have any queries, please contact *Fristam*.

Appli- cation	Shaft seal	Pump size
A	single	10/15 (bellows)
B	single	15 (without mechanical seal chamber)
C	single	15/17/20
D	single	22
E	single	25
F	single	27
G	double	17/20
H	double	22
I	double	25
J	double	27

Table 6 Standard shaft seal

Application A

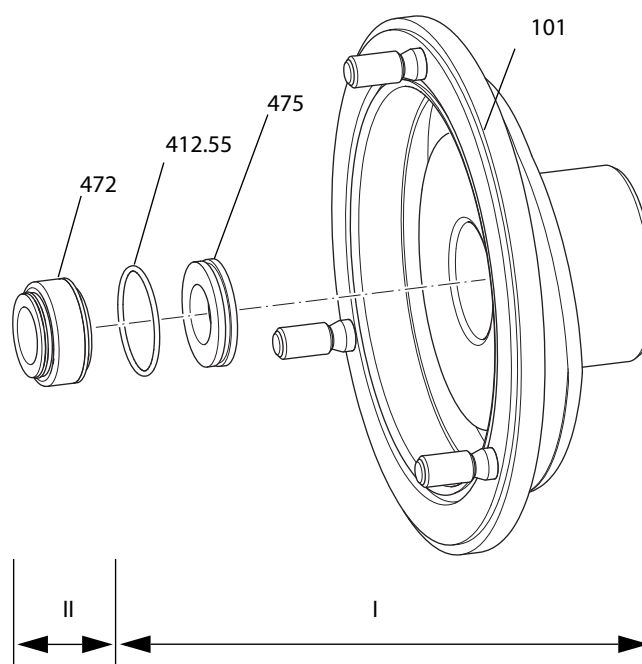

Fig. 34 Application A

The above figure shows the components grouped by assembly step:

I	Preassembly of pump casing
II	Completion of shaft assembly

Preassemble the pump casing (I):

1. Equip the stationary seal ring (**475**) with an O-ring (**412.55**).
2. Insert the stationary seal ring into the pump casing (**101**).

Note: The stationary seal ring must be installed in such a way that the smaller outer diameter faces the rotating seal ring.

The pump casing is now preassembled.

3. Slide the preassembled pump casing (**101**) over the shaft and connect it to the lantern as described in *Chapter 9.10.3, "Mounting of the Pump Casing," page 28.*

Complete the shaft assembly (II):

4. Slide the bellows (**472**) onto the shaft. The bellows includes an integrated rotating seal ring.
5. After completion of the shaft seal assembly, mount the impeller, see *Chapter 9.10.4, "Mounting of the Impeller," page 29.*

Application B

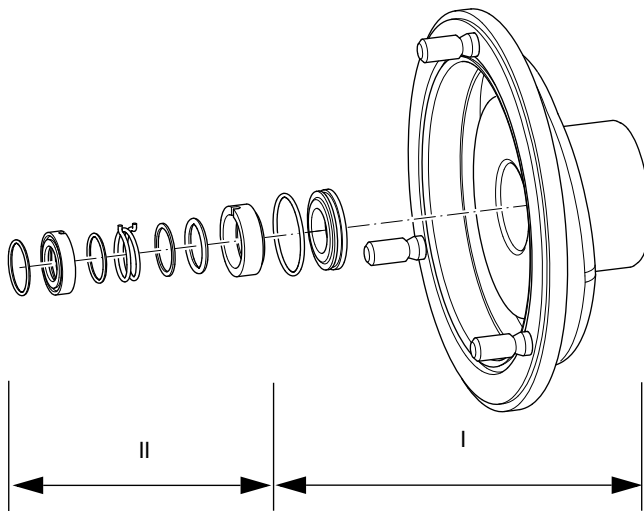

Fig. 35 Application B

The above figure shows the components grouped by assembly step:

I	Preassembly of pump casing
II	Completion of shaft assembly

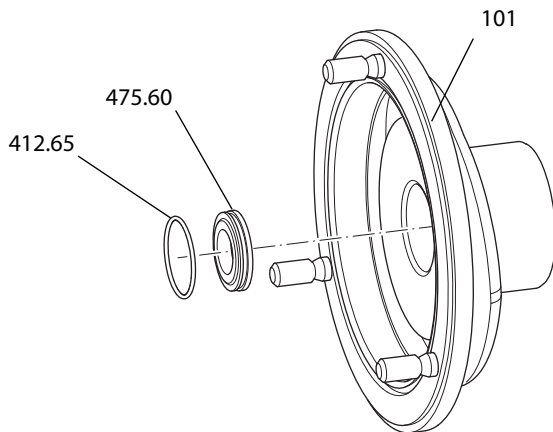

Fig. 36 Preassembling pump casing, application B

Preassemble the pump casing (I):

1. Equip the stationary seal ring (**475.60**) with an O-ring (**412.65**).
2. Insert the stationary seal ring into the pump casing (**101**).
The pump casing is now preassembled.
3. Mount the preassembled pump casing (**101**) on the shaft as described in *Chapter 9.10.3, "Mounting of the Pump Casing," page 28*.

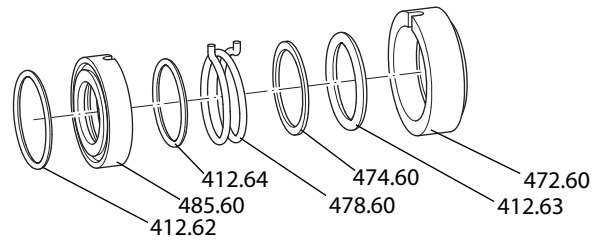

Fig. 37 Completion of shaft installation, application B

Complete the shaft assembly (II):

4. Equip the rotating seal ring (**472.60**) with an O-ring (**412.63**).
5. Equip the seal driver (**485.60**) with O-rings (**412.62**) and (**412.64**).
6. Slide the rotating seal ring together with the thrust collar (**474.60**), the spring (**478.60**) and the seal driver onto the shaft. Ensure that the protruding spring ends engage in the rotating seal ring and the seal driver.
7. After completion of the shaft seal assembly, mount the impeller, see *Chapter 9.10.4, "Mounting of the Impeller," page 29*.

Application C

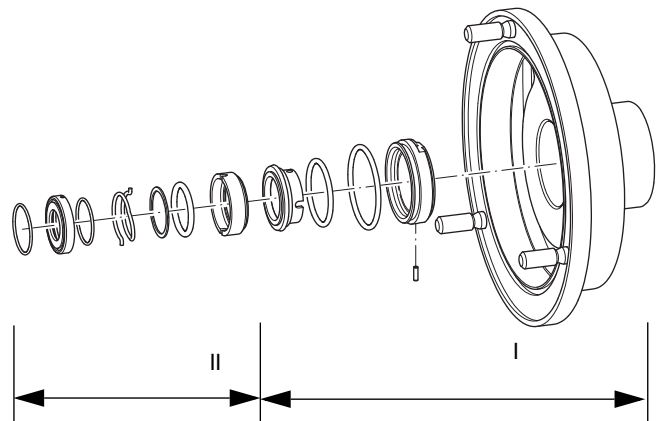

Fig. 38 Application C

The above figure shows the components grouped by assembly step:

I	Preassembly of pump casing
II	Completion of shaft assembly

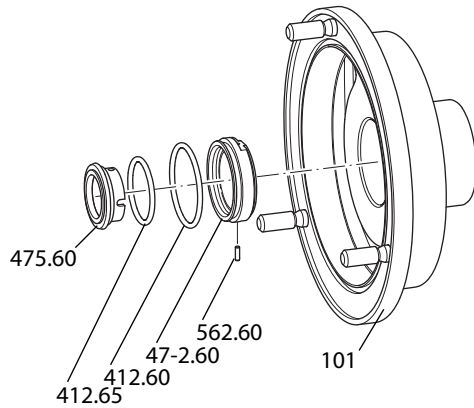

Fig. 39 Preassembling pump casing, application C

Preassemble the pump casing (I):

1. Glue the cylindrical pin (**562.60**) into the mechanical seal chamber (**47-2.60**), using retaining compound.
 Note: Position the cylindrical pin in such a way that it fully engages in the bore in the stationary seal ring (**475.60**) but does not touch the shaft at step (7.).
2. Equip the mechanical seal chamber with O-rings (**412.60**).
3. Depending on the model, the mechanical seal chamber might need to be equipped with an additional O-ring (**412.61**). For details, see "Sectional Drawing of Shaft Seal".
4. Insert the preassembled mechanical seal chamber into the pump casing (**101**).
5. Depending on the model, the mechanical seal chamber might need to be secured with a snap ring (**93-1.60**). For details, see "Sectional Drawing of Shaft Seal".
6. Equip the stationary seal ring (**475.60**) with an O-ring (**412.65**).
7. Insert the stationary seal ring into the mechanical seal chamber.
 Note: Insert the stationary seal ring in such a way that the cylindrical pins of the mechanical seal chamber engage in the bore of the stationary seal ring.

The pump casing is now preassembled.

8. Mount the preassembled pump casing (**101**) on the shaft as described in Chapter 9.10.3, "Mounting of the Pump Casing," page 28.

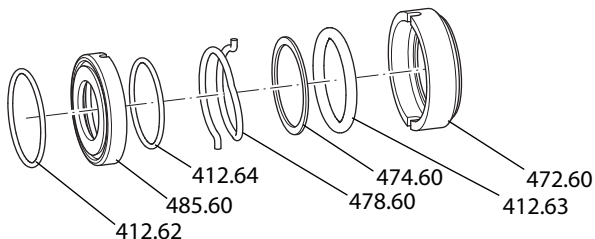

Fig. 40 Completion of shaft assembly, application C

Complete the shaft assembly (II):

9. Equip the stationary seal ring (**472.60**) with O-rings (**412.63**).

10. Equip the seal driver (**485.60**) with O-rings (**412.62**) and (**412.64**).
11. Slide the rotating seal ring together with the thrust collar (**474.60**), the spring (**478.60**) and the seal driver onto the shaft. Ensure that the protruding spring ends engage in the rotating seal ring and the seal driver.
12. After completion of the shaft seal assembly, mount the impeller, see Chapter 9.10.4, "Mounting of the Impeller," page 29.

Application D

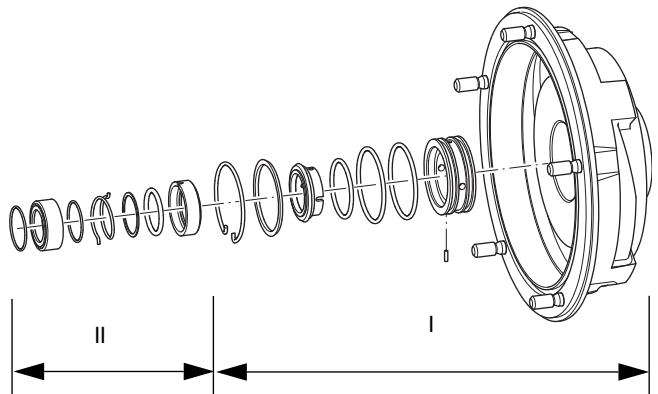

Fig. 41 Application D

The above figure shows the components grouped by assembly step:

I	Preassembly of pump casing
II	Completion of shaft assembly

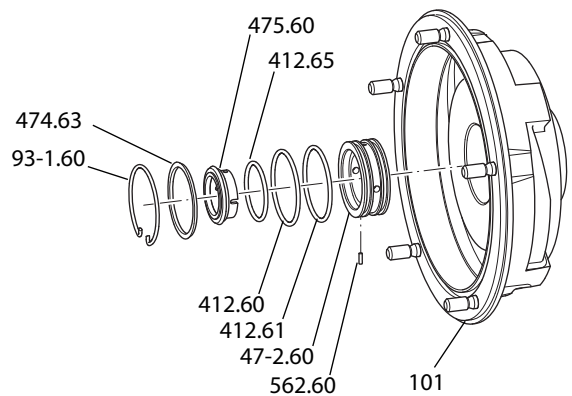

Fig. 42 Preassembling pump casing, application D

Preassemble the pump casing (I):

1. Equip the stationary seal ring (**475.60**) with an O-ring (**412.65**).
2. Insert the stationary seal ring into the mechanical seal chamber (**47-2.60**).
3. Glue the cylindrical pin (**562.60**) into the mechanical seal chamber, using retaining compound.

Note: Position the cylindrical pin in such a way that it fully engages in the bore in the stationary seal ring but does not touch the shaft after completion of the assembly.

4. Equip the mechanical seal chamber with O-rings (**412.60**) and (**412.61**).
5. Insert the preassembled mechanical seal chamber into the pump casing (**101**).
6. Equip the pump casing with a thrust collar (**474.63**) and secure it with a snap ring (**93-1.60**).

The pump casing is now preassembled.

7. Mount the preassembled pump casing (**101**) on the shaft as described in Chapter 9.10.3, "Mounting of the Pump Casing," page 28.

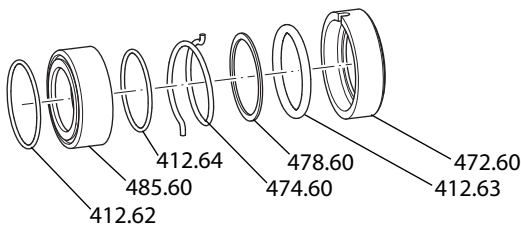

Fig. 43 Completion of shaft assembly, application D

Complete the shaft assembly (II):

8. Equip the stationary seal ring (**472.60**) with O-rings (**412.63**).
9. Equip the seal driver (**485.60**) with O-rings (**412.62**) (outside) and (**412.64**) (inside).
10. Slide the rotating seal ring together with the thrust collar (**474.60**), the spring (**478.60**) and the seal driver onto the shaft. Ensure that the protruding spring ends engage in the rotating seal ring and the seal driver.
11. After completion of the shaft seal assembly, mount the impeller, see Chapter 9.10.4, "Mounting of the Impeller," page 29.

Application E

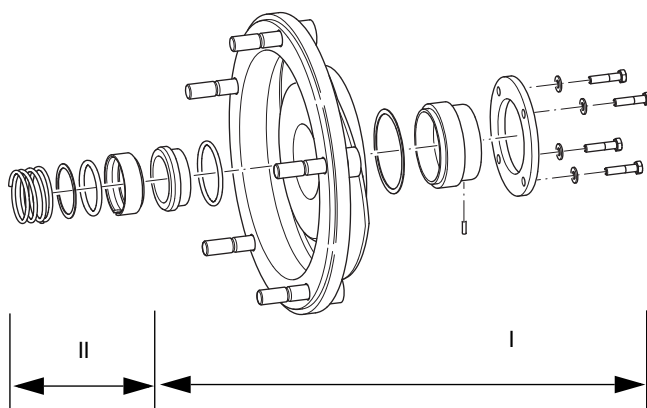

Fig. 44 Application E

The above figure shows the components grouped by assembly step:

I	Preassembly of pump casing
II	Completion of shaft assembly

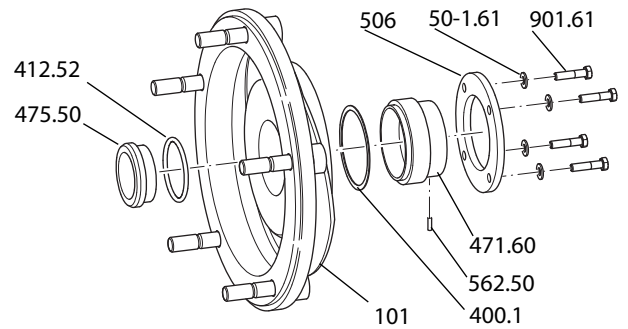

Fig. 45 Preassembling pump casing, application E

Preassemble the pump casing (I):

1. Glue the cylindrical pin (**562.50**) into the mechanical seal chamber (**471.60**), using a retaining compound.

Note: Position the cylindrical pin in such a way that it fully engages in the elongated bore of the stationary seal ring (**475.50**).

2. Place the flat seal (**400.1**) together with the mechanical seal chamber on the pump casing (**101**).
3. Mount the retaining ring (**506**) on the mechanical seal chamber and secure it with the hex cap screws (**901.61**) to the pump casing.
4. Equip the stationary seal ring with an O-ring (**412.52**).
5. Insert the stationary seal ring into the mechanical seal chamber.

Note: Insert the stationary seal ring in such a way that the cylindrical pins of the mechanical seal chamber engage in the elongated bores of the stationary seal ring.

The pump casing is now preassembled.

6. Mount the preassembled pump casing (**101**) on the shaft as described in Chapter 9.10.3, "Mounting of the Pump Casing," page 28.

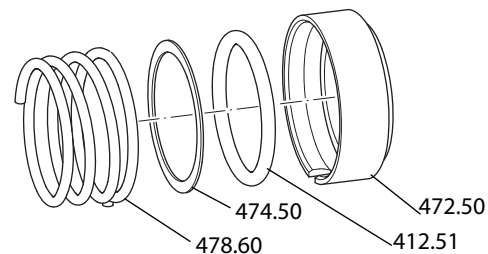

Fig. 46 Completion of shaft assembly, application E

Complete the shaft assembly (II):

7. Equip the stationary seal ring (**472.50**) with O-rings (**412.51**).
8. Slide the rotating seal ring together with the thrust collar (**474.50**) and the spring (**478.60**) onto the shaft. Ensure that the protruding spring ends engage in the rotating seal ring.

- After completion of the shaft seal assembly, mount the impeller, see *Chapter 9.10.4, "Mounting of the Impeller," page 29A*.

Application F

Preparation

- Mount the pump casing (see *Chapter 9.10.3, "Mounting of the Pump Casing," page 28*)
- Slide the fixing sleeve onto the shaft.
- Mount the impeller (see *Chapter 9.10.4, "Mounting of the Impeller," page 29*)
- Check the clearance (see *Chapter 9.9, "Checking of the Clearances," page 20*).
- Remove the pump head (see *Chapter 9.8, "Pump Head Removal," page 18*).

Clearance too large

- ▶ Grind down the fixing sleeve.
- Remove the pump casing (see *Chapter 9.8, "Pump Head Removal," page 18*)
 - Remove the fixing sleeve from the shaft seal kit. The position of the fixing sleeves are in the "Sectional drawing of shaft seal" of the "Order-related documents" in the enclosed documentation. The fixing sleeves are marked by graining, see *Chapter 9.9, "Checking of the Clearances," page 20*.
 - Grind the fixing sleeve to the necessary size.
 - Mount the pump casing See *Chapter 9.10, "Pump Head Attachment," page 20*.
 - Measure the clearance again.

Clearance too small

- ▶ Use a new fixing sleeve. Contact Fristam.

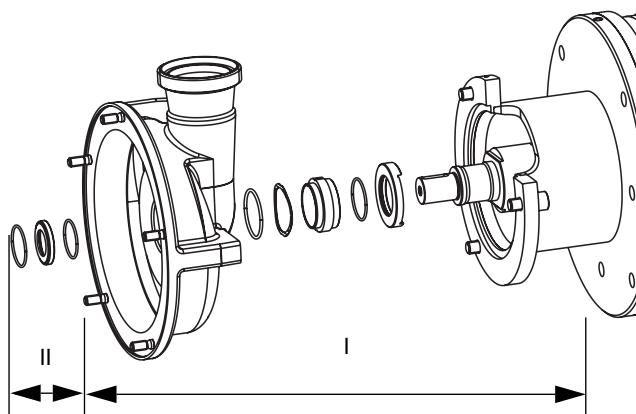

Fig. 47 Application F

In the figure above, the components are grouped by assembly steps:

I	Pre-assemble the pump casing.
II	Cease mounting on the shaft

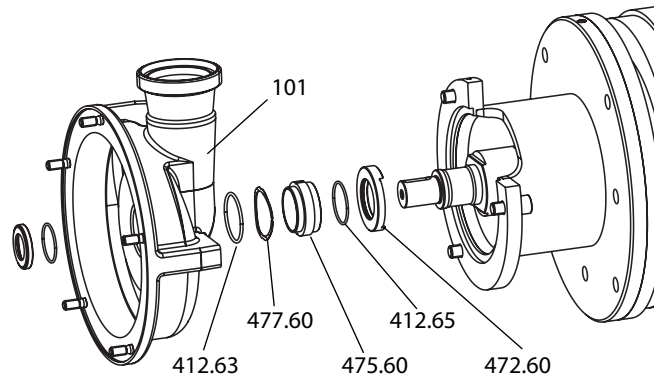

Fig. 48 Preassemble the pump casing, application F

In order to pre-assemble the pump casing (I):

- Place the O-ring (**412.65**) onto the seal ring (**472.60**) and then slide it onto the shaft.
- Insert the O-ring (**412.63**) into the pump casing (**101**).
- Install the spring (**477.60**) and counter ring (**475.60**) into the pump casing.

Note: Introduce the stationary seal ring in such a way that the cylinder pins engage in the pump casing in the recesses of the stationary seal ring.

The pump casing is now assembled.

- Mount the pre-assembled pump casing (**101**) onto the shaft, as described in *Chapter 9.10.3, "Mounting of the Pump Casing," page 28*.

To cease assembly on the shaft (II):

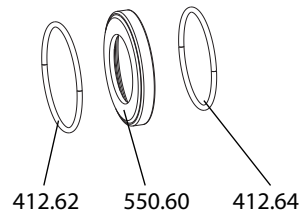

Fig. 49 Cease mounting on the shaft, application F

- Place the O-rings (**412.62**) and (**412.64**) on the fixing sleeve(**550.60**).
- Slide the fixing sleeve onto the shaft.
- End assembly of the shaft seal by attaching the impeller, see *Chapter 9.10.4, "Mounting of the Impeller," page 29*.

Application G

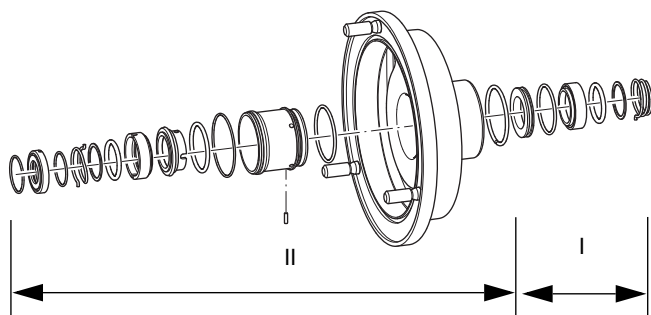

Fig. 50 Application F

I	Mounting of shaft seal on shaft (motor side)
II	Mounting of shaft seal on shaft (pump side)

Mount the shaft seal on the motor side of the shaft (I):

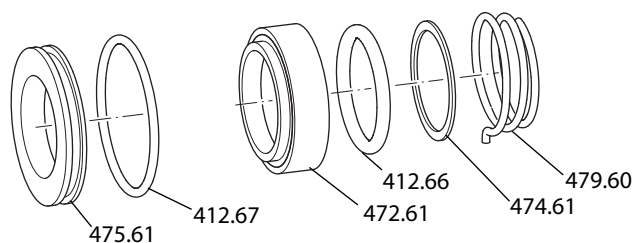

Fig. 51 Mounting shaft seal on motor side, application F

1. Equip the stationary seal ring (**472.61**) with an O-ring (**412.66**).
2. Slide the spring (**479.60**) together with the thrust collar (**474.61**) and the rotating seal ring (**472.61**) onto the shaft. Ensure that the protruding spring ends engage in the bore of the rotating seal ring.
3. Insert the O-ring (**412.67**) in the stationary seal ring (**475.61**).

Note: The stationary seal ring and the O-ring must be inserted into the mechanical seal chamber before the pump casing is mounted on the shaft.

The shaft seal on the motor side is now preassembled.

Mount the shaft seal on the pump side of the shaft (II):

4. To mount the shaft seal on the pump side of the shaft, proceed as described in Chapter, "Application C," page 22.

Application H

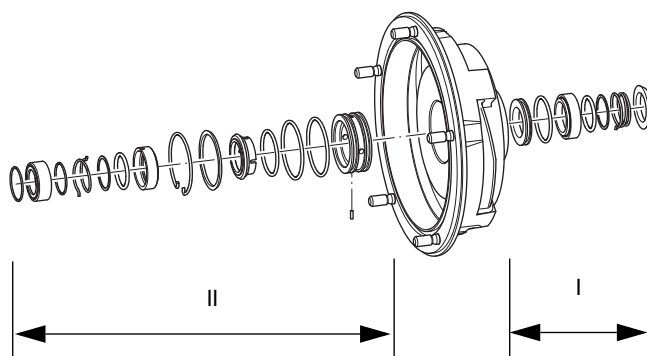

Fig. 52 Application G

The above figure shows the components grouped by assembly step:

I	Mounting of shaft seal on shaft (motor side)
II	Mounting of shaft seal on shaft (motor side)

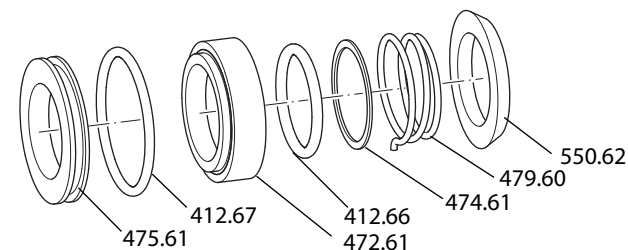

Fig. 53 Mounting of shaft seal on shaft (motor side), application G

Mount the shaft seal on the motor side of the shaft (I):

1. Slide the washer (**550.62**) onto the shaft.
2. Equip the stationary seal ring (**472.61**) with an O-ring (**412.66**).
3. Slide the spring (**479.60**) together with the thrust collar (**474.61**) and the rotating seal ring (**472.61**) onto the shaft. Ensure that the protruding spring ends engage in the elongated bore of the rotating seal ring.
4. Insert the O-ring (**412.67**) into the stationary seal ring (**475.61**).

Note: The stationary seal ring and the O-ring must be inserted into the mechanical seal chamber before the pump casing is mounted on the shaft.

The shaft seal on the motor side is now preassembled.

Mount the shaft seal on the pump side of the shaft (II):

5. To mount the shaft seal on the pump side of the shaft, proceed as described in Chapter, "Application D," page 23.

Application I

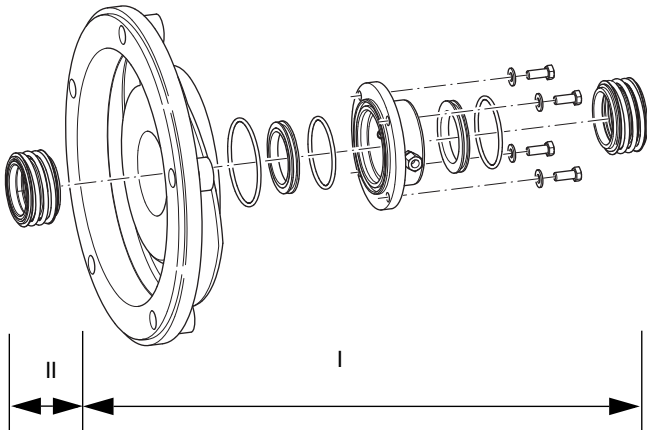

Fig. 54 Application H

The above figure shows the components grouped by assembly step:

I	Preassembly of pump casing
II	Completion of shaft assembly

Preassemble the pump casing (I):

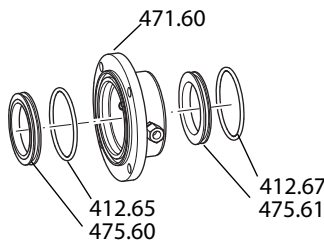

Fig. 55 Mounting the mechanical seal chamber, application H

1. Equip the stationary seal rings (**475.60**) and (**475.61**) with O-rings (**412.65**) and (**412.67**) and insert them into the mechanical seal chamber (**471.60**).

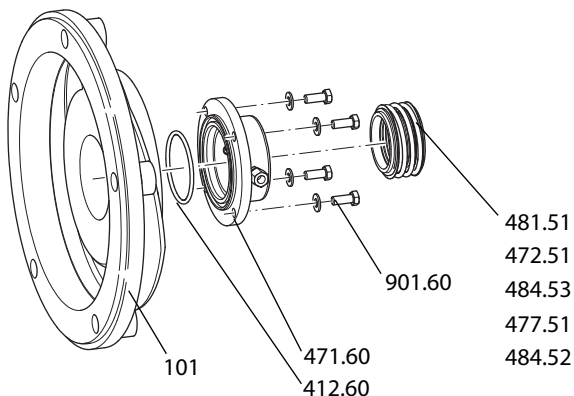

Fig. 56 Preassembling pump casing, application H

2. Equip the mechanical seal chamber with O-rings (**412.60**) and secure it with the hex cap screws (**901.60**) to the pump casing (**101**).

The pump casing is now preassembled.

3. Slide the bellows kit (**481.51**; **472.51**; **484.53**; **477.51**; **484.52**) onto the shaft.
4. Mount the preassembled pump casing (**101**) on the shaft as described in Chapter 9.10.3, "Mounting of the Pump Casing," page 28.

Complete the shaft assembly (II):

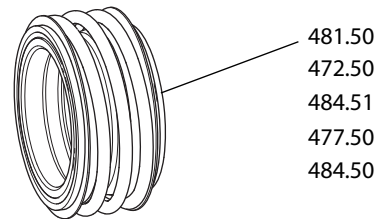

Fig. 57 Bellows kit, application H

5. Slide the bellows kit (**481.50**; **472.50**; **484.51**; **477.50**; **484.50**) onto the shaft.
6. After completion of the shaft seal assembly, mount the impeller, see Chapter 9.10.4, "Mounting of the Impeller," page 29.

Application J

Preparation

The preparatory measures are described in Chapter, "Application F," page 25.

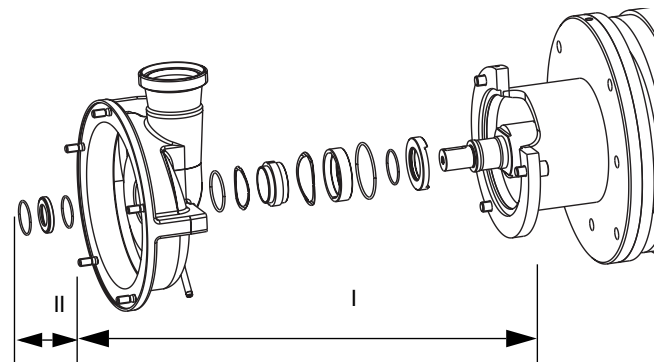

Fig. 58 Application J

In the figure above, the components are grouped by assembly steps:

I	Pre-assembly of the pump casing.
II	Cease mounting on the shaft

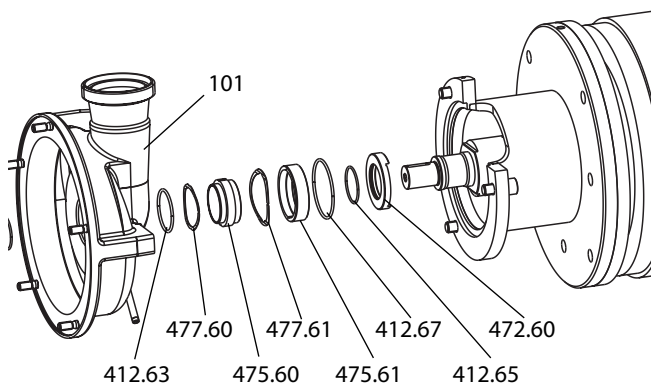

Fig. 59 Pre-assemble the pump casing, application J

In order to pre-assemble the pump casing (I):

1. Place the O-ring (**412.65**) onto the seal ring (**472.60**) and then slide it onto the shaft.
2. Insert the O-rings (**412.63**) and (**412.67**) into the pump casing (**101**).
3. Insert the springs (**477.60**) and (**477.61**) and stationary seal rings (**475.60**) and (**475.61**) into the pump casing.

Note: Introduce the stationary seal rings in such a way that the cylinder pins engage in the pump casing in the recesses of the stationary seal ring.

The pump casing is now assembled.

4. Mount the pre-assembled pump casing (**101**) onto the shaft, as described in Chapter 9.10.3, "Mounting of the Pump Casing," page 28.

To cease assembly on the shaft (II):

5. To cease assembly on the shaft (II), proceed as described in Chapter, "Application F," page 25.

9.10.3 Mounting of the Pump Casing

Pump With Flange Connection

1. Slide the preassembled pump casing (**42**) with the shims (**43**) over the shaft to the flange (**44**) and screw on (see Chapter 10.1, "Specifications," page 31).
2. Only for models K3 and KF3:
Mount the cover plates on the compact bearing support.

Pump With Clamp Connection

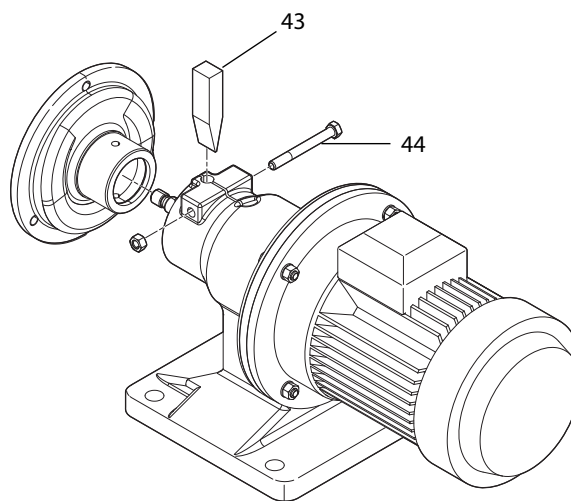

1. Slightly spread the clamp connection with a wedge (**43**).
2. Only for double shaft seal: Slide the motor-side seal set onto the pump shaft.
3. Install the entire shaft seal housing with seals into the pump casing and secure to prevent slippage.
4. Slide the pump casing over the pump shaft into the clamp connection and slightly tighten the clamp bolt (**44**).
5. Slide the pump-side seal set onto the shaft.
6. Mount the impeller; see Chapter 9.10.4, "Mounting of the Impeller," page 29.
7. Adjust the clearances by sliding the pump head inside the clamp connection (see Chapter 9.9, "Checking of the Clearances," page 20). Align the surface of the outlet side (discharge line connection) horizontally while doing so.
8. Tighten the clamp bolt (**44**):

	Thread	Tightening Torque
Special motor	M10	36 Nm
Standard motor	M10	45 Nm
	M12	75 Nm

Table 7 Tightening torques for clamp connection

9. Continue with Chapter 9.10.5, "Pump Sealing," page 29.

9.10.4 Mounting of the Impeller

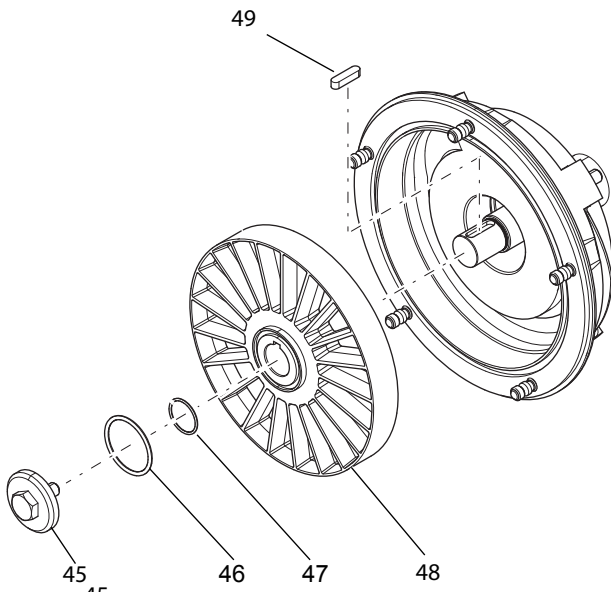

Fig. 60 Mounting of the impeller

1. Attach the impeller fastener (45) as follows according to the fastener type:

Impeller Nut

- ▶ Open the polyamide snap ring and place in the shaft groove.
- ▶ Screw the rotor nut hand-tight onto the shaft.

Impeller Screw

- ▶ Open the polyamide snap ring and place on the screw.
- ▶ Equip the impeller screw (45) with an O-ring (46) and screw hand-tight into the shaft.

Warning: Rotating machine parts. Severe pinching of hands.

- ▶ Block the impeller with a special tool.

2. Tighten the impeller fastener to the specified tightening torque. (See Table 8, "Tightening torques for impeller fastener".)

Pump Size	Thread	Impeller Fastener Tightening Torque [Nm]
FZP 10	M12 x 1.5	40
FZ 15	M16	60
FZ 17	M16	100
FZ 20	M16	100
FZ 22	M12	60
FZ 25	M16	85
FZ 27	M12	27

Table 8 Tightening torques for impeller fastener

9.10.5 Pump Sealing

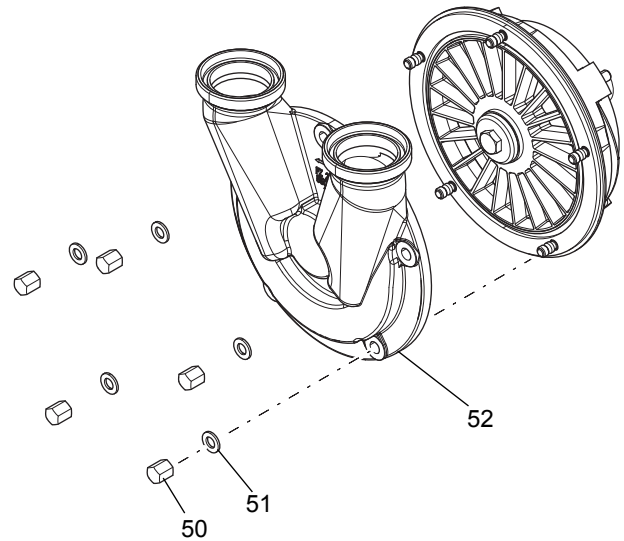

Fig. 61 Pump cover

- ▶ Slide the pump cover (52) with the O-ring onto the pump casing and screw on with washers (51) and nuts (50).

Note: The outlet of the channels from the pump cover and the pump casing must be properly aligned.

9.11 Design FZ 27: Mounting and aligning the pump shaft

Note: The pump shaft must be mounted and aligned after the IEC motor has been replaced.

⚠ CAUTION

Rotating parts

Bruising and severe injuries

- ▶ Switch off the motor and secure it against restarting.

1. Remove the key from the motor shaft pin.
2. In electric motors with a capacity of more than 30 kW: Insert the half-key supplied.
3. Degrease the motor shaft pin and pump shaft bore with a cleaning agent e.g. "OKS 2610 Universal Cleaner".
4. Rub down the motor shaft pin and edges of the keyway with sanding paper to remove unevenness and burrs.
5. Coat the motor shaft pin in the area of the shaft shoulder with sealing gel, e.g. "Stucarit 309".
6. Push the pump shaft with the shrink ring onto the motor shaft pin, right up to the shaft shoulder.
7. Tighten the screws of the shrink disk in a crosswise manner:

Thread	Tightening torque
M5	6 Nm
M6	12 Nm

Thread	Tightening torque
M8	30 Nm

- Attach the dial gauge onto the pump shaft to check the run-out tolerance.

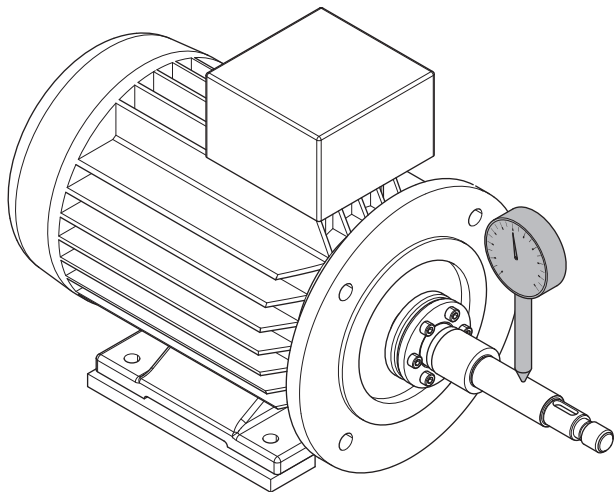

Fig. 62 Run-out tolerance measurement of the pump shaft

- Depending on the motor performance, check the run-out of the pump shaft. – Motor <30 kW: max. run-out tolerance = 0.06 mm – motor > 30 kW: max. run-out tolerance = 0.08 mm.
- If necessary, align the run-out of the pump shaft

9.12 Model L: Coupling Replacement

Only use couplings approved by *Fristam*. The coupling must be appropriate for the characteristic curve of the pump. If you have any questions, please contact *Fristam*.

Procedure

- Turn off the motor and prevent it from being able to be turned on accidentally.
- Remove the coupling guard.
- Detach the pump and the motor from the base frame or the foundation and remove.
- Remove the coupling according to the coupling manufacturer's specifications.
- Dispose of the old coupling parts in an environmentally friendly manner.
- Mount new coupling parts on the pump shaft and the motor shaft.
- Place the pump on the base frame or the foundation so that the pump shaft can be connected to the motor shaft with the coupling.
- Screw the threaded fastener slightly into the bearing block.
- Check the parallel and angular misalignment of the shafts.

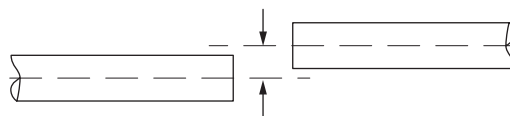

Fig. 63 Parallel misalignment

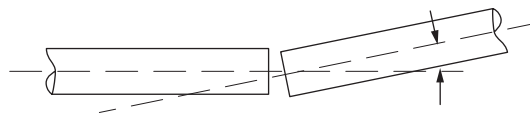

Fig. 64 Angular misalignment

- Minimize deviations from the angular and parallel misalignment. Realign the shafts if necessary, or add shims.
- Screw the pump and motor to the base frame or the foundation.
- Fasten the coupling according to the coupling manufacturer's specifications.
- Mount the coupling guard.

10 Appendix 1

10.1 Specifications

10.1.1 Tightening Torques for Screws and Nuts

Material: Steel, Strength Class: 8.8

Thread	M6	M8	M10	M12	M16	M20
Tightening Torque [Nm]	11	27	54	93	230	464

Material: Stainless Steel, Strength Class: 70

Thread	M6	M8	M10	M12	M16	M20
Tightening Torque [Nm]	7.4	17.5	36	62	150	303

Material: Stainless Steel, Strength Class: 80

Thread	M6	M8	M10	M12	M16	M20
Tightening Torque [Nm]	10	24	49	80	203	393

10.1.2 Noise Emissions

Pump Size	Noise Level dB(A)
FZP 10	62
FZ 15	65
FZ17	72
FZ 20	79
FZ 22	82
FZ 25	87
FZ 27	86

Table 9 Noise emissions

The specified values apply to operation of the pump at the best efficiency point at 50 Hz (see "Pump Characteristic Curve"). The noise level can differ greatly at other working points.

10.2 Maintenance Intervals

Model	Interval	Maintenance Task	Chapter
All with "Sealing and Quenching Liquid" option	Once a day	Check the sealing or quenching liquid.	See Chapter 9.3, "Inspection of Sealing and Quenching Liquid (Optional)," page 16.
L 2	Once a day	Check the oil level.	
KF 2, KF 3	5,000 h	Lubricate the shaft bearing.	See Chapter 9.5.3, "Models K and KF," page 17.
KF 1	5,000 h	Lubricate the shaft bearing.	See Chapter 9.5.3, "Models K and KF," page 17.
L 2	5,000 h	Change the oil.	See Chapter 9.5.1, "Model L 2," page 16.
L 1	5,000 h	Lubricate the shaft bearing.	See Chapter 9.5.2, "Model L1," page 16.
All	When necessary	Replace the shaft seal.	See Chapter , "IEC standard motor in model FZ 27," page 18.
All	When necessary	Replace the motor.	See Chapter 9.6, "Motor Replacement," page 17.
All	According to manufacturer's specifications	Lubricate the motor bearings.	See Chapter 9.4, "Lubrication of Motor Bearings," page 16.

Table 10 Maintenance intervals

For information on motor maintenance intervals, please see the "Motor Operator's Manual."

10.3 Troubleshooting Table

Problem	Possible Cause	Remedy
Pump either does not pump or pumps irregularly.	Suction line blocked or clogged.	Open or clean suction line.
	Suction filter contaminated.	Clean suction filter.
	Discharge-side shut-off valve closed.	Open discharge line.
	Pump not completely filled with liquid.	Install pipe system so that casing is still filled with liquid when pump is at a standstill.
	Pump with geodesic suction head ¹ ; liquid level falls at standstill.	Install foot valve in suction line.
	Suction line leaky (drawing in air).	Seal suction line.
	Foot valve blocked or contaminated.	Reestablish proper function of foot valve; clean.
	Suction head too high.	Lower pump; reduce suction head.
	Air pocket in suction line.	Lay suction line at steady incline.
	Excessive air or gas in pumping medium.	Install vent valve.
	Air ingress at shaft seal.	Check shaft seal installation. Replace elastomers.
	Cavitation at impeller inlet; resistance in suction line too high; suction head too high; NPSHa values not adapted to pump.	Optimize suction line; increase inlet height; lower media temperature; contact <i>Fristam</i> .
	Flow rate too high.	Discharge-side valve opened too wide.
Discharge line diameter too large.		Reduce nominal pipe size; insert orifice plate.
Impeller diameter too large.		Trim impeller outside diameter. Reduce speed with frequency converter. Contact <i>Fristam</i> .
Flow rate too low; discharge head too low.	Selected pump too small.	Contact <i>Fristam</i> .
	Selected impeller diameter too small.	Contact <i>Fristam</i> ; replace impeller.
	Direction of rotation of motor incorrect.	Exchange connections on motor terminal box.
	Speed too low (voltage incorrect).	Correct connection according to motor rating plate.
	Nominal pipe sizes too small.	Use larger pipe diameters.
	Pipe resistances in suction and/or discharge line too high.	Optimize pipe system; reduce elbows and valves. Contact <i>Fristam</i> .
	Pipe clogged or full of deposits.	Clean pipes.
	Foreign objects/deposits in impeller.	Remove impeller and clean.
	Impeller incorrectly adjusted.	Check impeller clearance and readjust.
Density of pumping medium too high. Viscosity of pumping medium too high.	Contact <i>Fristam</i> .	
Metal noise.	Foreign objects in pump interior.	Disassemble, inspect, and repair.
	Impeller catching.	Readjust impeller clearance; tighten impeller nut using torque wrench.
	Pump/shaft seal running dry.	Immediately supply pumping medium; open suction valve.
Flow noise.	Operation contrary to design in overload or part-load range.	Adjust working point to design.
	Flow losses in suction line too high.	Increase nominal sizes; shorten lines; prevent outgassing.
	Cavitation.	Check condition for NPSH rating; contact <i>Fristam</i> .

Table 11 Troubleshooting table

Problem	Possible Cause	Remedy
Vibrations.	Suction and discharge lines stressing pump impermissibly.	Support pipes so that pump is not stressed; possibly install vibration dampers; keep water hammers away from pump.
Excessive heating of shaft bearing.	Bearing damage.	Replace bearing.
Motor power consumption too high.	Flow rate too high.	Throttle discharge line or reduce speed with frequency converter.
	Impeller diameter too large.	Trim impeller diameter; contact <i>Fristam</i> .
	Viscosity and/or density of pumping medium too high.	Contact <i>Fristam</i> .
	Massive damage to shaft bearing; shaft deformed.	Disassemble, inspect, and have repaired by <i>Fristam</i> .
Leakage at shaft seal.	Mechanical seal or rotary shaft seal mechanical damage/wear.	Replace shaft seal and elastomers; possibly switch materials. Contact <i>Fristam</i> .
	Shaft seal running dry; suction head too high; pumping media temperature too high.	Increase pump inlet pressure; decrease suction head; use double shaft seal; contact <i>Fristam</i> .
	Sealing water head too high.	Adjust using throttle valve.
	Sealing water head too low.	Replace rotary shaft seal.
	Water tubes clogged (resulting in damage to rotary shaft seal); sealing water not clean.	Clean water tubes; adjust water inlet and outlet; use drinking water-quality water with temperature of max. 70°C.
	Temperature of pumping medium too high.	Contact <i>Fristam</i> ; convert to double shaft seal.

Table 11 Troubleshooting table

¹The "geodesic suction head" is the vertical distance between the suction-side liquid level and the center of the impeller.

10.4 Number Key

The general number key refers to the appended sectional drawings. The part numbers conform to DIN 24250.

Part Number	Name
101	Pump casing
108	Stage casing
160	Cover
13-1	Back casing panel
13-2	Housing insert
130	Casing part
132	Spacer
135	Wearing bush
154	Intermediate wall
156	Outlet side
18-1	Spherical cap bearing
18-2	Vibration damper
182	Base
21-1	Synchronizing shaft
213	Drive shaft
23-1	Rotor
26-1	Bracket for mechanical seal chamber
230	Impeller
32-1	Angular contact ball bearing
32-2	Cylindrical roller bearing
32-3	Deep groove ball bearing
32-4	Tapered roller bearing
321	Radial ball bearing
322	Radial roller bearing
325	Needle bearing
330	Bearing support
331	Bearing block
341	Drive lantern
344	Bearing support lantern
350	Bearing housing
360	Bearing cap
40-4	Half-length taper grooved pin
400	Flat seal
410	Profile seal
411	Gasket
412	O-ring
421	Rotary shaft seal
422	Felt ring
423	Labyrinth ring
433	Mechanical seal
45-1	Thrust ring
451	Stuffing box housing
454	Stuffing box ring
47-1	Spring with washer
47-2	Mechanical seal chamber
47-3	Wedge seal
47-5	Ring nut
471	Seal cover
472	Rotating seal ring
474	Thrust collar
475	Stationary seal ring
476	Stationary seal ring support
477	Mechanical seal spring

Part Number	Name
478	Right spring
479	Left spring
481	Bellows
482	Bellows support
484	Spring retainer
485	Seal driver
500	Ring
50-1	Split lock washer
50-2	V-ring
50-3.60	Set collar
504	Spacer ring
520	Sleeve
523	Shaft sleeve
524	Shaft protective sleeve
525	Spacer sleeve
54-1	Cover bushing
54-2	Bushing
54-3	Stationary bushing
540	Bushing
543	Spacer bushing
55-1	Serrated lock washer
550	Washer
551	Spacer washer
554	Washer
561	Grooved pin
56-1	Roll pin
56-2	Grooved pin with round head
560	Pin
562	Cylindrical pin
59-2	Dished-type lock washer
59-3	Shrink ring
59-4	Lantern
59-5	Membrane
642	Oil level sight glass
680	Enclosure
68-1	Support plate
68-2	Foam strip
68-3	Bracket for enclosure
68-4	Orifice plate
68-5	CF guard plate
681	Coupling guard
701	Bypass line
710	Pipe
71-1	Connection pipe
715	Hose pipe
722	Flange adapter
723	Flange
724	Blind flange
733	Pipe clamp
751	Valve housing
755	Valve bolt
756	Valve spring
759	Valve plate

Part Number	Name
800	Motor
801	Flange motor
87-1	Gearbox
87-2	Gear cover
87-3	Gear cap
87-4	Gear base
839	Contact
872	Gearwheel
89-1	Filler piece
89-2	Spherical cap frame
89-3	Motor foot
89-4	Handle
89-5	Protective cap
89-6	Wheel
89-8	Flat bar steel
89-9	Motor bracket
89-10	Motor bracket
89-11	Spherical cap base support
892	Base plate
894	Console
897	Guide piece
90-1	Stud bolt
90-3	Tapered pin
90-4	Half-length taper grooved pin
90-5	Eyebolt
900	Screw
901	Hex cap screw
902	Threaded stud
903	Screw plug
904	Set screw
906	Impeller bolt
909	Adjusting screw
91-1	Slotted cheese head screw
913	Bleed screw
914	Socket screw
92-1	Star knob nut, long
92-2	Star knob nut, short
92-3	Cap nut
92-4	Rotor nut
92-5	Forcing screw
92-6	Rotor fastener
92-7	Nut with flange
920	Hex nut
921	Shaft nut
922	Impeller nut
923	Bearing nut
93-1	Snap ring
930	Retainer
931	Retaining washer
932	Snap ring
940	Key
941	Woodruff key
950	Spring

10.5 EC Declaration of Conformity

The manufacturer: FRISTAM Pumpen KG (GmbH&Co.)
Kurt-A.-Körber-Chaussee 55
21033 Hamburg, Germany

declares that the following product (pump with motor):

- centrifugal pump types FP, FPE, FP...V, FPH, FPEH, FPH...V, FSPE, FSP...V, FM, FZ, FC, CF, CFE, FPM and FSM
- Positive displacement pump types: FK, FKL, FL, FL2, and FL3
- Powder mixer type: PM
- (for serial number, see cover page of operating manual)

conforms to all relevant requirements of the **EU Machinery Directive (2006/42/EC)**.

The machine also conforms to the relevant requirements laid down in the **Low Voltage Directive (2014/35/EU)** and the **EMC Directive (2014/30/EU)** No. 1935/2004 and FDA.

The above product conforms to the following standards:

- DIN EN 809:2012-10: Pumps and pump units for liquids - Common safety requirements
- DIN EN ISO 12100:2011-03: "Safety of machinery - General principles for design, risk assessment and risk reduction"

Documentation officer: Julia Friedsch

Telephone: +49(0)40 72556-107

Address: see manufacturer address

Hamburg, 30 October 2020



Julia Friedsch / Head of Quality Management

10.6 EG Declaration of Incorporation

The manufacturer: FRISTAM Pumpen KG (GmbH&Co.)
Kurt-A.-Körber-Chaussee 55
21033 Hamburg, Germany

declares that the following product (pump without motor):

- centrifugal pump types FP, FPE, FP...V, FPH, FPEH, FPH...V, FSPE, FSP...V, FM, FZ, FC, CF, and CFE
- Positive displacement pump types: FK, FKL, FL, FL2, and FL3
- Powder mixer type: PM
- (for serial number, see cover page of operating manual)

is an incomplete machine in accordance with the **Machinery Directive (2006/42/EC) Annex II B**.

The relevant, basic safety and health requirements of Annex I of the above-mentioned Directive have been applied and adhered to.

The incomplete machine further meets all the provisions of the Directive (EC) No. 1935/2004 and FDA.

The incomplete machine may only be put into operation when it has been determined that the machine into which the incomplete machine is to be installed complies with the Machinery Directive (2006/42/EC).

The above product conforms to the following standards:

- DIN EN 809:2012-10: Pumps and pump units for liquids - Common safety requirements
- DIN EN ISO 12100:2011-03: "Safety of machinery - General principles for design, risk assessment and risk reduction"

The manufacturer undertakes to transmit the special documentation on the partly completed machinery electronically to the national authorities when requested to do so.

The technical documentation belonging to the machine as per Annex VII Part B have been prepared.

Documentation officer: Julia Friedsch

Telephone: +49(0)40 72556-107

Address: see manufacturer address

Hamburg, 30 October 2020



Julia Friedsch / Head of Quality Management

11 Appendix 2 – Assembly Instructions (Optional)

11.1 Safety Instructions

These assembly instructions are addressed solely to specialized employees.

11.2 Scope

These assembly instructions apply to pumps supplied without motors (optional) and preassembled.

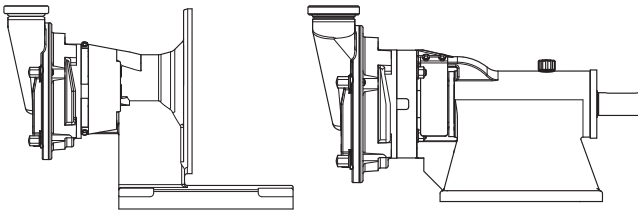

Fig. 65 Pump without motor, coupling, or base frame illustrated using models KF and L

The following specifications in the "Original Operator's Manual" for complete machines do not apply in this case:

- Chapter 10.5, "EC Declaration of Conformity," page 35,
- Chapter 10.1.2, "Noise Emissions," page 31.

11.2.1 Rating Plate

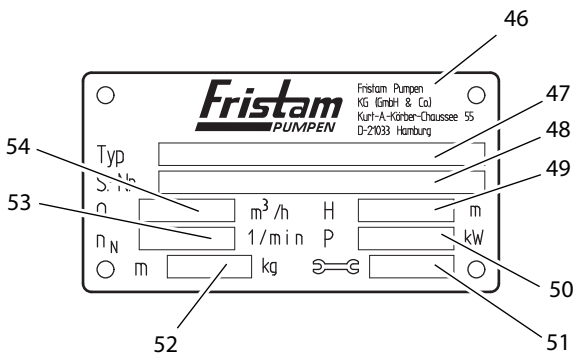

Fig. 66 Rating plate for pump without drive

46	Manufacturer
47	Typ: pump series, pump size, model, version
48	S.-Nr.: serial number of the pump
49	H: discharge head [m]; without drive: no specification
50	P: motor output [kW]; without drive: no specification
51	Year of manufacture
52	m: mass (pump without drive) [kg]
53	n_N : rated speed [1/min]; without drive: no specification
54	Q: flow rate [m ³ /h]; without drive: no specification

11.3 Moving Without Motor

Transportation may only be performed by trained personnel.

The pump can be moved using an industrial truck or a crane.

Always move the pump in the installation condition.

11.3.1 Safety Instructions

Falling or Unsecured Parts

Severe crush injuries.

- ▶ Always wear gloves when performing transportation-related work.

Incorrect Positioning of Pump for Transportation

Leakage of caustic, toxic, or contaminating liquids. Personal injury and material damage from contamination.

- ▶ Always move the pump in the installation condition.

Open, Unsealed Pipe Fittings

Material damage from contamination, impact, or moisture in the pump.

- ▶ Remove the pipe fitting covers just prior to connection to the pipes.

11.3.2 Moving With Industrial Trucks

⚠ WARNING

Unsecured Parts

Serious injuries from crushing, pinching of extremities, material damage.

- ▶ Before moving the pump secure it to prevent it from tipping over. Secure the pump to the pallet with tie-down straps, or screw the pump to the pallet.

Preparation

- ▶ Ensure that the pump is adequately secured to the pallet, for example, with straps; see Fig. 67, "Moving with pallet truck," page 36.

Procedure

1. Pick up the pallet with the forks on the industrial truck.
2. Carefully move the pallet to the designated location and set down.

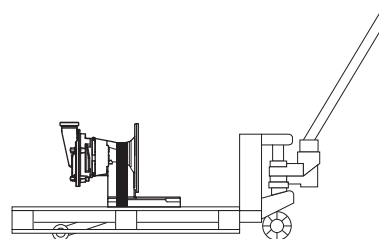

Fig. 67 Moving with pallet truck

11.3.3 Moving With Crane

⚠ WARNING

Falling Parts

Death from crushing, pinching of extremities, material damage.

- ▶ Only use suitable means of conveyance and hoists that are designed for the total weight of the pump.

Information on the pump weight can be found on the pump's rating plate as well as in the *Order-Related Documents* in the attached documents.

- ▶ Do not leave the pump in a raised position for longer than necessary.
- ▶ Ensure that the area below the pump is clear of people.

⚠ WARNING

Swinging Parts

Crushing and serious injuries.

- ▶ Start and stop the crane with pump smoothly.
- ▶ Ensure that the danger zone of the pump is clear of people.

Auxiliary Equipment

- Hoists: round slings tested in accordance with DIN EN 1492-1 and 1492-2
- Eyebolt and suitable eyebolt lifting devices

Preparation

- ▶ Remove load-securing devices.

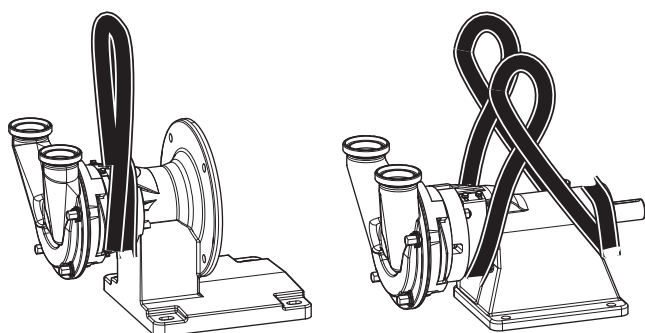

Fig. 68 Moving with crane illustrated using the KF and L

To move the K/KF pump:

Procedure

1. Wrap the round sling twice around the lantern neck (see Fig. 68, "Moving with crane illustrated using the KF and L").
2. Guide the other end of the round sling to the crane hook and hook on.
3. Position the center of gravity to ensure that the pump is secure when lifted.
4. Lift the pump.

To move the L pump:

Procedure

1. Wrap the round sling twice around the back end of the bearing block (see Fig. 68, "Moving with crane illustrated using the KF and L").
2. Lay the other end of the round sling between the lantern and the pump casing. Do not lay the round sling over any sharp edges or corners.
3. Guide both loops to the crane hook and rotate by 180° to ensure that the belt will not slip on the hook.
4. Position the center of gravity to ensure that the pump is lifted horizontally.
5. Lift the pump.

11.4 Installation Location

Please see the operator's manual *Chapter 6.2, "Installation Location," page 11* for the basic installation location requirements.

11.5 Pump Installation

Model K

Prerequisites (Customer-Side)

- Suitable motor

NOTICE

Incorrectly Designed Motor

Destruction of pump.

- ▶ Only use motors that have been adapted to the pump characteristic curves and that correspond to the pump size specified during project planning. If you have any questions, please contact *Fristam*.

Procedure

1. Insert the key into the slot on the motor.
2. Slide the motor shaft into the compact bearing support.
3. Screw the motor to the compact bearing support. Tighten screws crosswise.
4. Screw the motor to the base frame or the foundation.

Model KF

Prerequisites (Customer-Side)

- Suitable motor

NOTICE

Incorrectly Designed Motor

Destruction of pump.

- ▶ Only use motors that have been adapted to the pump characteristic curves and that correspond to the pump size specified during project planning. If you have any questions, please contact *Fristam*.

Procedure

1. Insert the key into the slot on the motor.
2. Slide the motor shaft into the compact bearing support.
3. Screw the motor to the compact bearing support. Tighten screws crosswise.
4. Screw the compact bearing support with base to the base frame or the foundation.

Model L

Prerequisites (Customer-Side)

- Suitable motor
- Adequately sized coupling
- Common installation surface for motor and pump so that pump shaft can be aligned with gear motor shaft

NOTICE

Incorrectly Designed Motor and Coupling

Destruction of pump and coupling.

- ▶ Only use motors and couplings that have been adapted to the pump characteristic curves. If you have any questions, please contact *Fristam*.

Note: Please see the coupling supplier documentation for reference dimensions for the coupling.

Procedure

1. Mount the coupling parts on the pump shaft and the motor shaft.
2. Place the pump on the base frame or the foundation so that the pump shaft can be connected to the motor shaft with the coupling.
3. Screw the threaded fastener slightly into the pump base.
4. Check the parallel and angular misalignment of the pump and motor shafts.
5. Minimize deviations from the angular and shaft misalignment. If necessary, realign or add shims.
6. Screw the pump and motor to the base frame or the foundation.
7. Fasten the coupling according to the coupling manufacturer's specifications.

8. Install a noncontact, barrier-providing protective device (coupling guard) in accordance with *Section 1.4, entitled "Required Characteristics of Guards and Protective Devices," of the Machinery Directive 2006/42/EC*.
9. The pump is now installed. Do not commission the pump unless the requirements of the EC Machinery Directive are met for the complete machine.

Note: Continue with *Chapter 4, "Transportation," page 10*.

Fristam Pumpen KG (GmbH & Co.)
Kurt-A.-Körber-Chaussee 55
21033 Hamburg
GERMANY

Tel.: +49-40-72556-0

Fax: +49-40-72556-166

E-mail: info@fristam.de